

Rescue cards for Passenger cars

Mercedes-Benz • AMG • McLaren • Maybach • smart



Mercedes-Benz



Mercedes-Benz

Preface

Dear Reader,

One of Mercedes-Benz's main priorities has traditionally been to guarantee the highest possible standards of safety.

A comprehensive safety concept extends to providing rescue crews with specific information about our vehicles and their safety systems.

The top priority of the rescue crew is to save lives. The rescue team must be able to gain access to the accident victims as quickly as possible without exposing them or themselves to additional danger.

In order to do this, the rescue services must be properly trained. In addition, knowledge of vehicle-specific accessibility options and of the function and operation of the safety systems is absolutely essential.

In addition to its *“Guidelines for Rescue Services”*, Mercedes-Benz now produces *“rescue cards”* providing information in condensed form for many model series and models **dating from the start of production in 1971** (from 1995 for campers).

Vehicle owners and emergency services can download the rescue cards from the internet free of charge.

The rescue cards are produced in full color. This helps you understand and take in the content quickly. For this reason, we strongly recommend that you ***print the cards in color***.

Daimler AG

Technical Information and Workshop Equipment (GSP/OR)

Note

The body reinforcements marked on the rescue card generally identify those areas of the vehicle which require significantly greater effort to cut using standard tools. The references to body reinforcements are therefore restricted to those areas where cutting may be necessary in order to rescue the victims, and of which the crew chief should be aware.

© 2012 by Daimler AG

This document, including all its parts, is protected by copyright.

Any commercial processing or use requires the previous written consent of Daimler AG, Department GSP/ORR, HPC R822, W002, D-70546 Stuttgart, Germany.

This applies in particular to reproduction, distribution, alteration, translation, microfilming and storage and/or processing in electronic systems, including databases and online services.

How do I find the correct rescue card?

Models and variants

Each Mercedes-Benz rescue card is applicable for one model series.

Model variants within a model series (e.g. gasoline or diesel engine) are identifiable on the rescue card by means of appropriate item numbers in the illustrations and the corresponding legends.

Occupant protection systems

The type and number of airbags, emergency tensioning retractors etc. in the vehicle is not evident from the vehicle's model or variant designation.

The occupant protection systems are therefore illustrated with the maximum possible equipment. This gives rescue crews an overview of where occupant protection systems might be installed in the vehicle.

Determining the vehicle model from the vehicle ident. no.

Identification plate on the vehicle:

Please refer to the operator's manual to find out where the identification plate is located in your vehicle.

Example of vehicle ident. no. (see illustration on the right)

WDD2120xx1Axxxxxx

In this example the vehicle is a model 212; the 0 identifies it as a sedan.

Your vehicle can be additionally identified by means of the year of manufacture and by the vehicle illustrations on the rescue card.

The relevant rescue card can therefore be found under Sedan - Model 212



Identification plate, example of an E-Class sedan, model 212

- A The first 3 letters and numbers are the world manufacturer code
- B Digits 4 to 6 indicate the vehicle model
- C Digit 7 indicates the body type

Body types:

- 0 Sedan
- 1 Long sedan
- 2 Station wagon
- 3 Coupé
- 4 Convertible/roadster
- 9 Special editions (e.g. GLK)

190
Sedan
Model 201

1982-1993

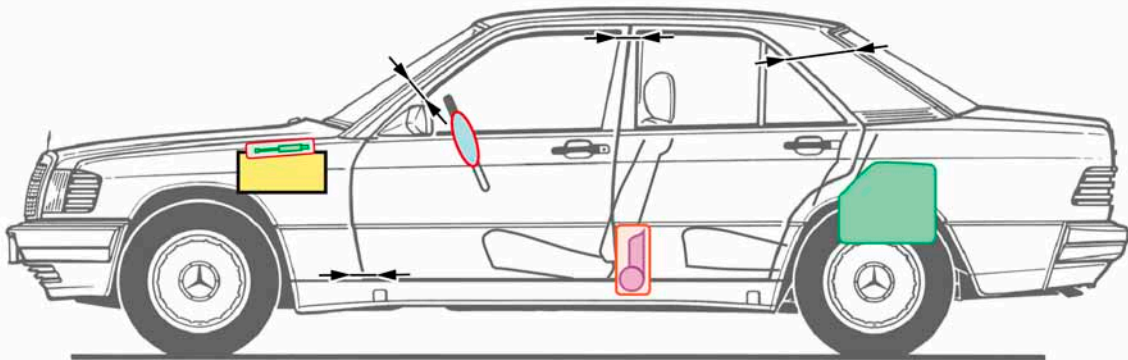
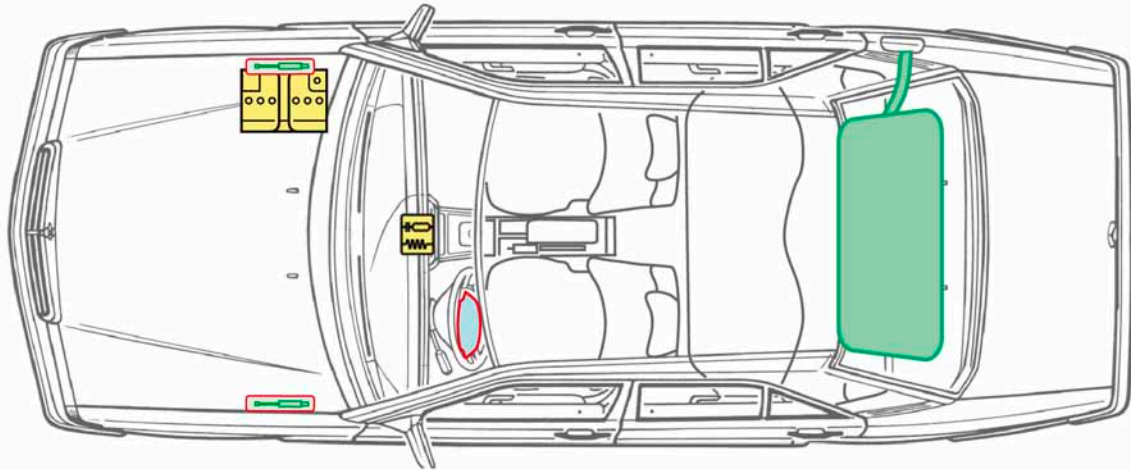

Legend



Airbag



Structural reinforcements

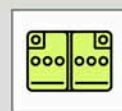

Battery

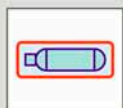

Gas generator



Rollover protection



High-voltage components



Seat belt tensioner



Fuel tank



Cutting points



Gas filled spring device



Control unit

**A-Class
Sedan**

Model 168

1997-2004

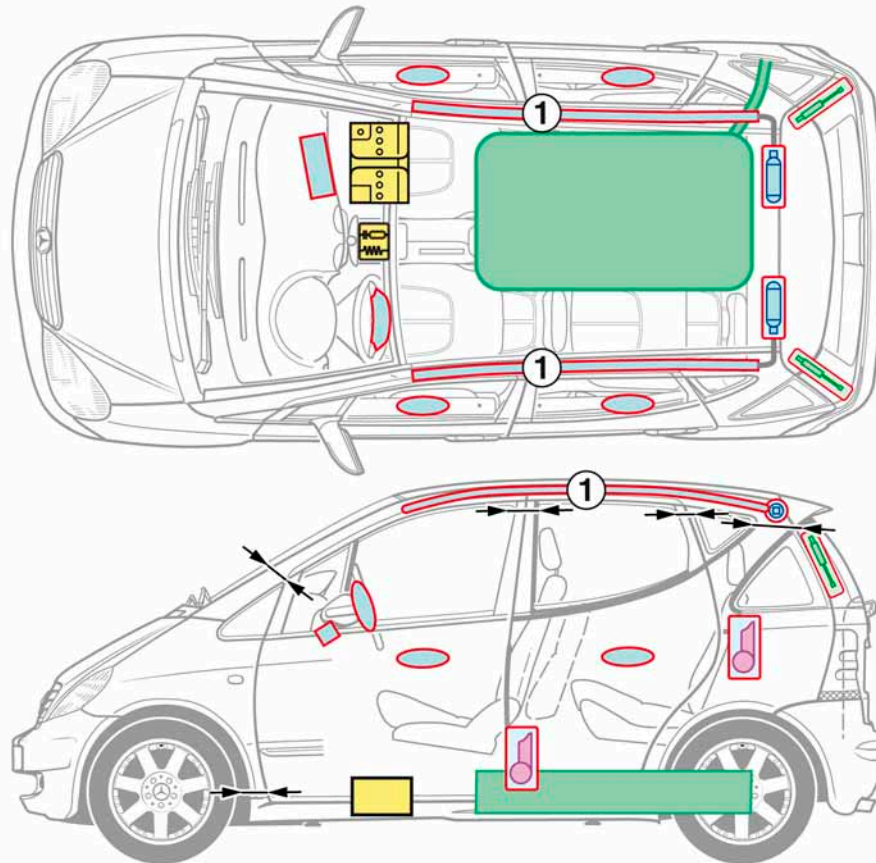

1 as of 2001

Legend



Airbag



Structural reinforcements

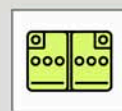

Battery



Gas generator



Rollover protection



High-voltage components



Seat belt tensioner



Fuel tank



Cutting points

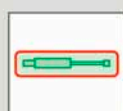

Gas filled spring device



Control unit





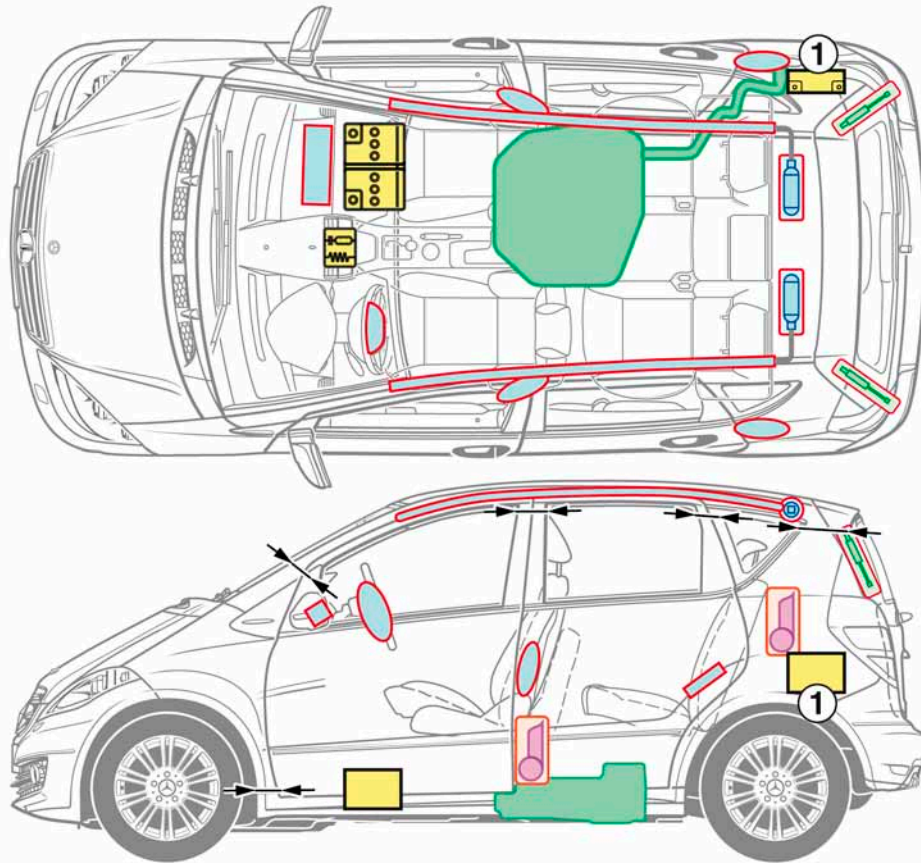



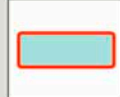

**A-Class
Sedan
Model 169**

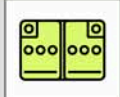
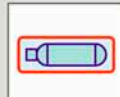
2004-2012

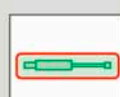

1 Additional battery BlueEFFICIENCY models

Legend

	Airbag		Structural reinforcements		Battery
	Gas generator		Rollover protection		High-voltage components
	Seat belt tensioner		Fuel tank		Cutting points
	Gas filled spring device		Control unit		

A-Class
E-Cell
Sedan
Model 169

as of 2010

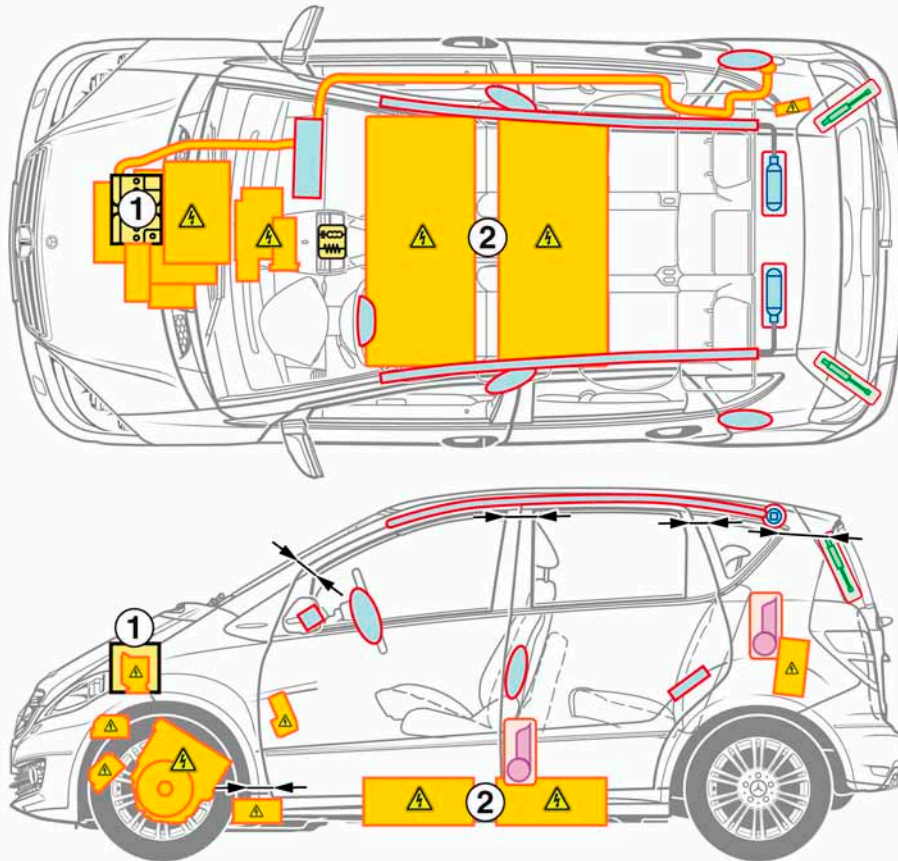

1 12 V-battery
2 High-voltage battery

Legend



Airbag



Structural reinforcements

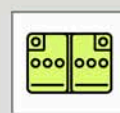

Battery



Gas generator



Rollover protection



High-voltage components



Seat belt tensioner



Fuel tank



Cutting points



Gas filled spring device



Control unit

**A-Class
Sedan
Model 176**

as of 2012

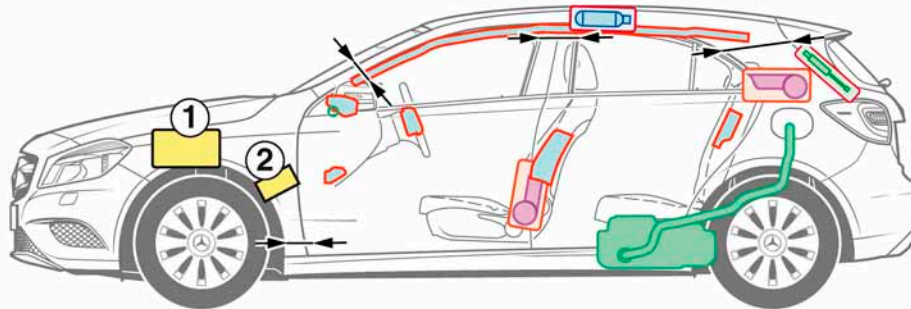
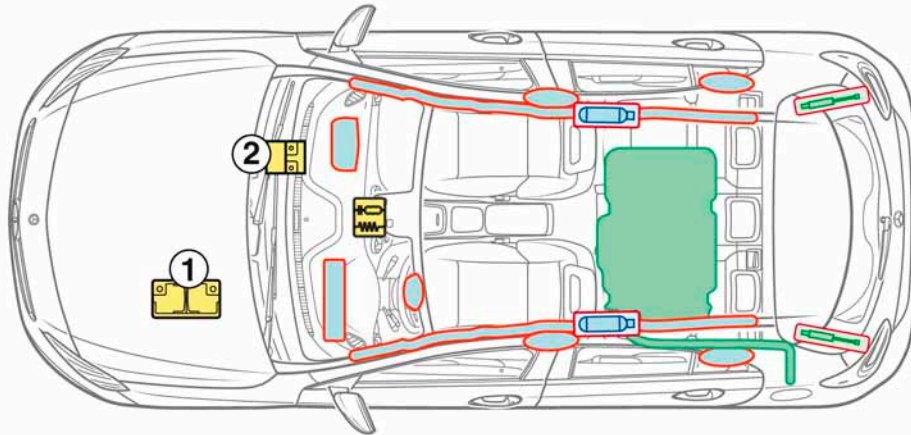

- 1 Power supply battery
- 1 Additional battery ECO Start-Stop

Legend



Airbag



Structural reinforcements

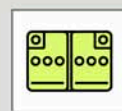

Battery

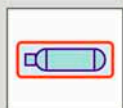

Gas generator



Rollover protection



High-voltage components



Seat belt tensioner



Fuel tank



Cutting points



Gas filled spring device



Control unit





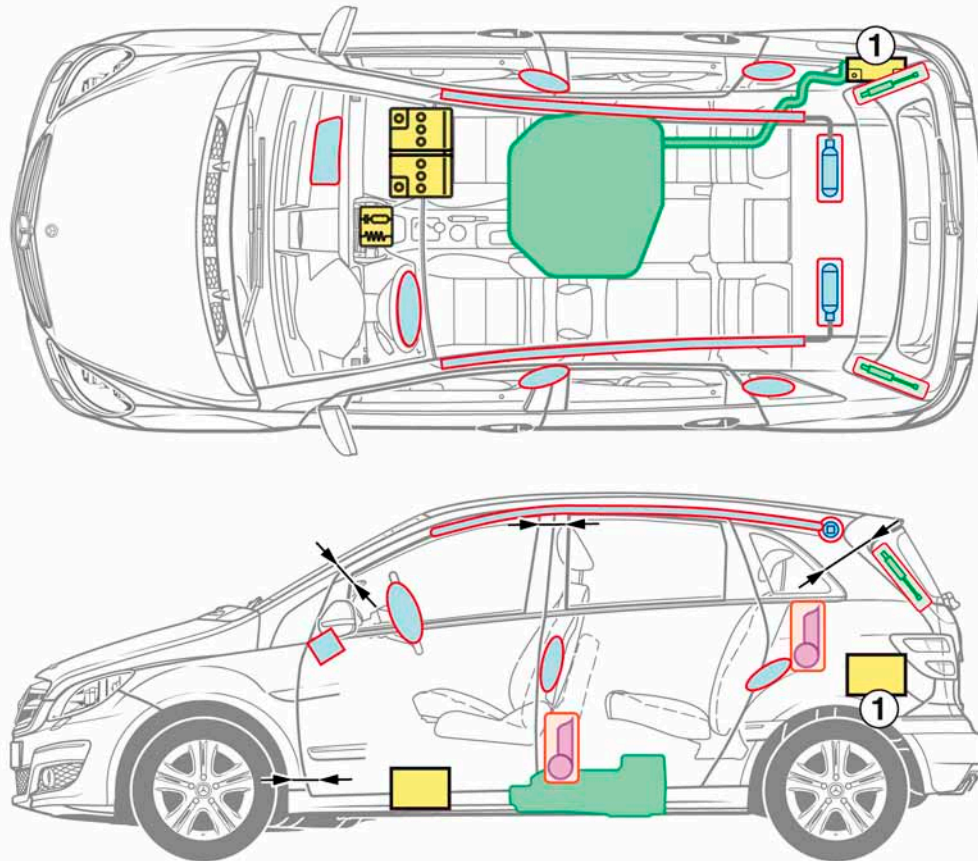



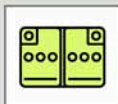
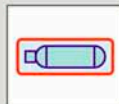

**B-Class
Sedan
Model 245**

2005-2011



1 Additional battery BlueEFFICIENCY models

Legend

	Airbag		Structural reinforcements		Battery
	Gas generator		Rollover protection		High-voltage components
	Seat belt tensioner		Fuel tank		Cutting points
	Gas filled spring device		Control unit		

**B-Class
NGT
Sedan
Model 245**

as of 2005

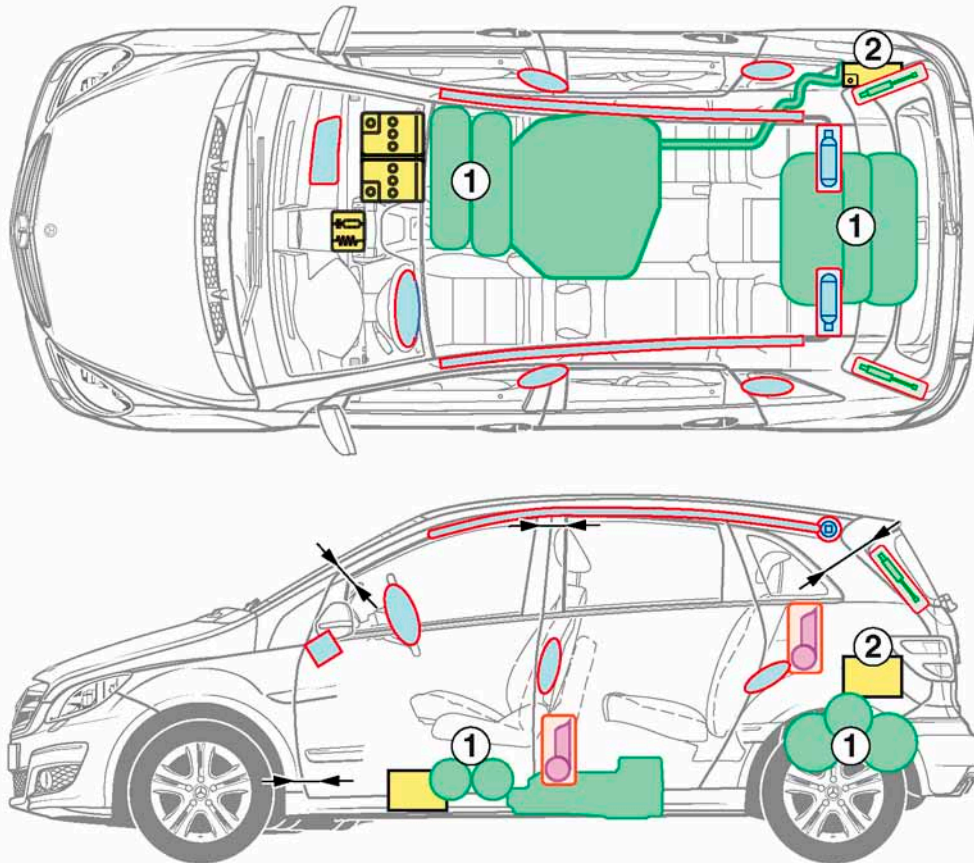

- 1 Gas cylinder
- 2 Additional battery BlueEFFICIENCY models

Legend



Airbag



Structural reinforcements

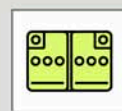

Battery



Gas generator



Rollover protection



High-voltage components



Seat belt tensioner



Fuel tank



Cutting points



Gas filled spring device







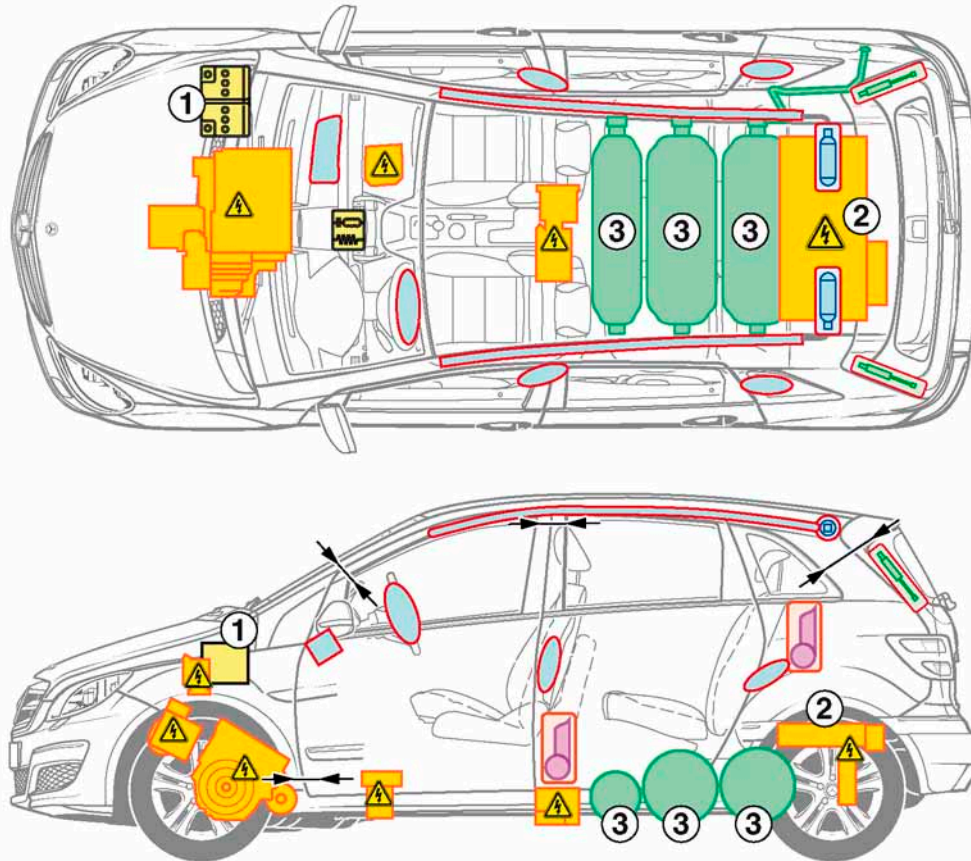

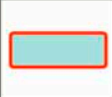

Control unit

B-Class
F-Cell
 Fuel Cell
 drive system
Model 245
 as of 2010

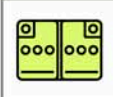
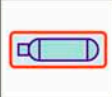

- 1 12 V-battery
- 2 High-voltage battery
- 3 Hydrogen cylinder

Legend

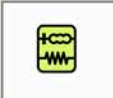
	Airbag		Structural reinforcements		Battery
	Gas generator		Rollover protection		High-voltage components
	Seat belt tensioner		Fuel tank		Cutting points
	Gas filled spring device		Control unit		

**B-Class
Sedan
Model 246**

as of 2011

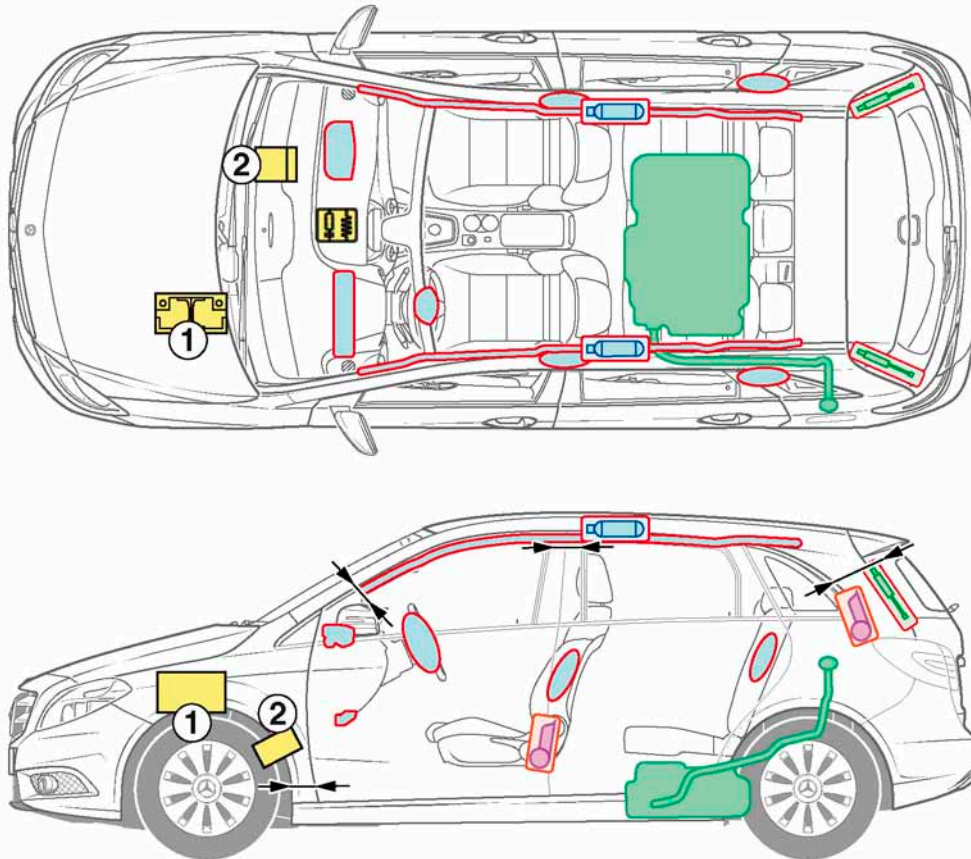

- 1 Power supply battery
- 2 Additional battery ECO Start-Stopp

Legend



Airbag



Structural reinforcements

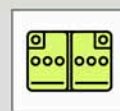

Battery



Gas generator



Rollover protection



High-voltage components



Seat belt tensioner



Fuel tank



Cutting points



Gas filled spring device



Control unit

**C-Class
Sedan
Model 202**

1993-2001

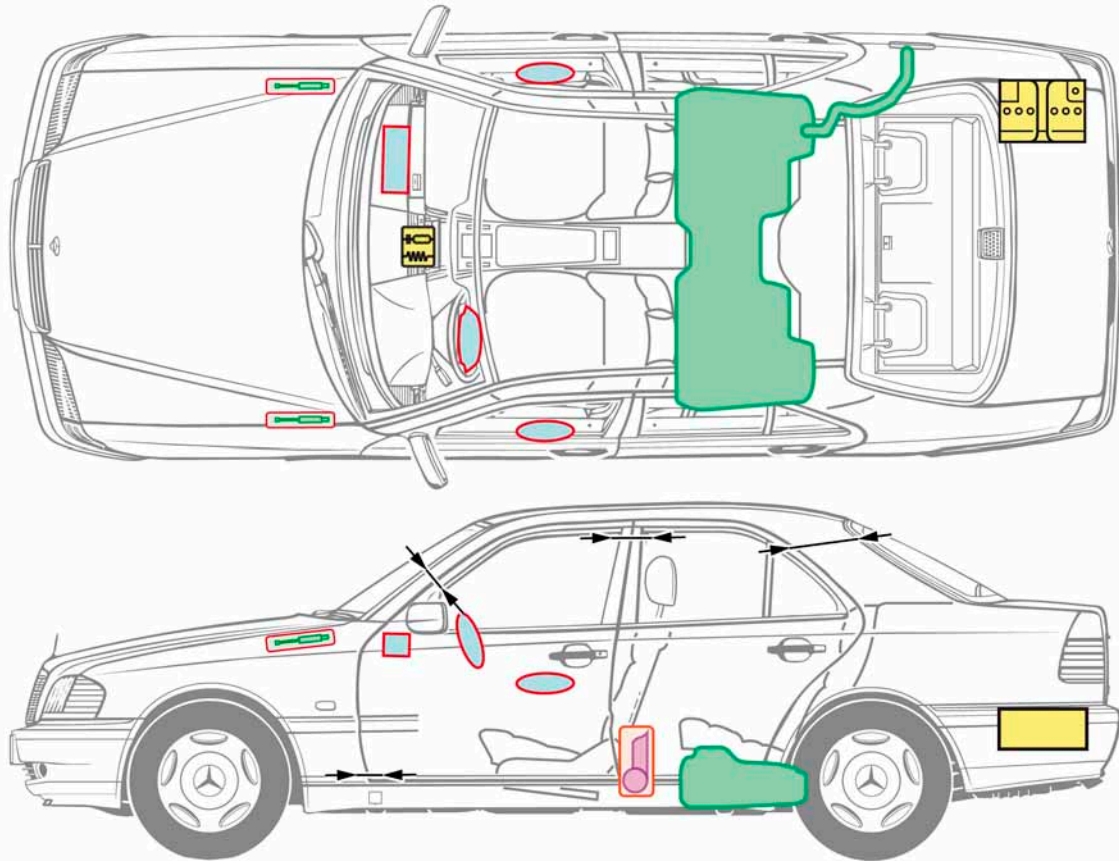

Legend



Airbag



Structural reinforcements

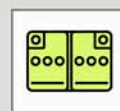

Battery



Gas generator



Rollover protection



High-voltage components



Seat belt tensioner



Fuel tank



Cutting points

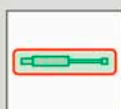

Gas filled spring device



Control unit

**C-Class
Sedan
Model 203**

2000-2007

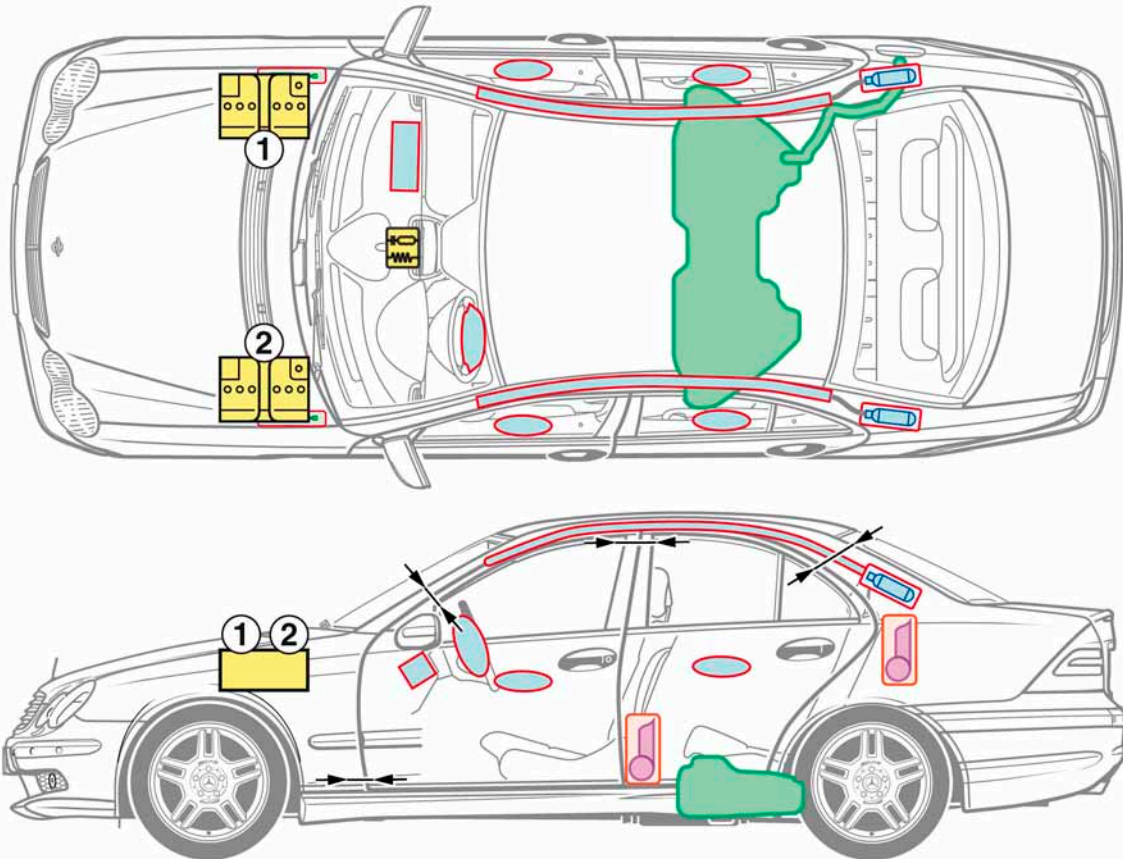

1 LHD vehicle
2 RHD vehicle

Legend



Airbag



Structural reinforcements

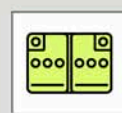

Battery



Gas generator



Rollover protection



High-voltage components



Seat belt tensioner



Fuel tank



Cutting points

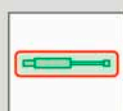

Gas filled spring device



Control unit





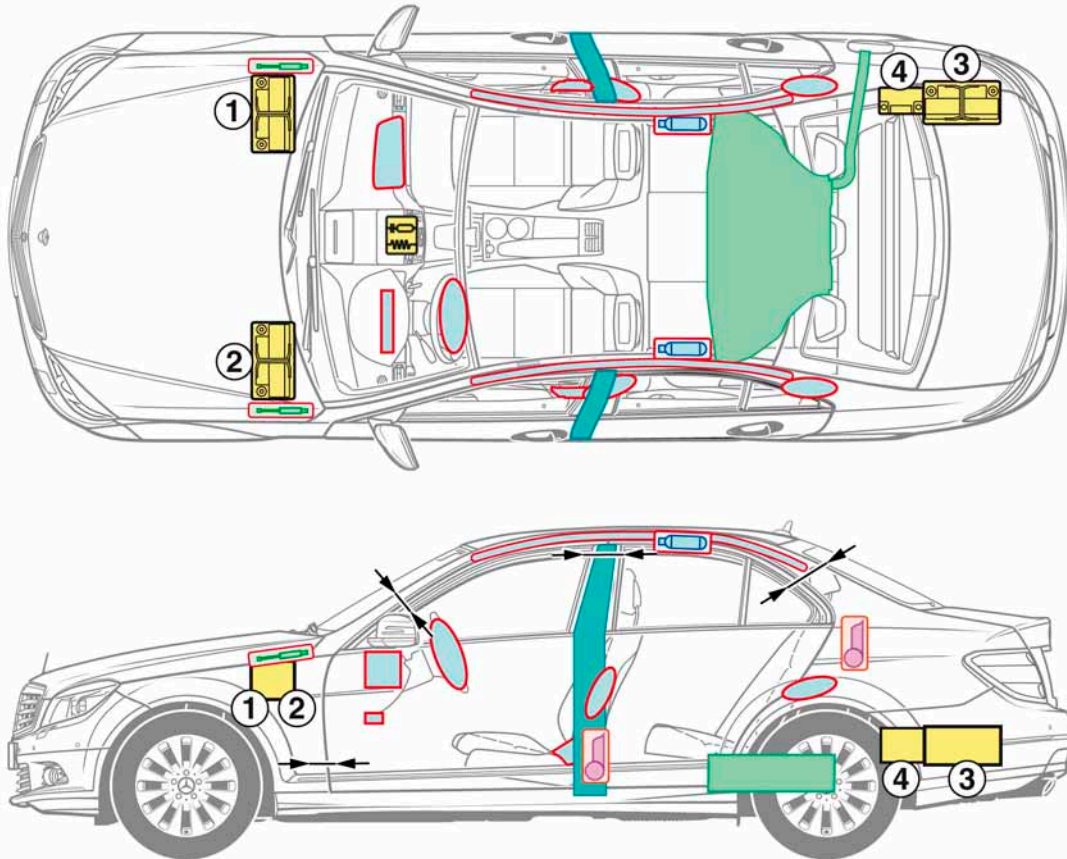



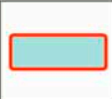

**C-Class
Sedan
Model 204**

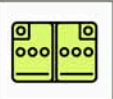
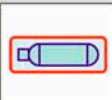
as of 2007



- 1 Power supply battery with gasoline engine, as of 1.12.2009 with 4- and 8-cylinder diesel engine and AMG, LHD
- 2 Power supply battery with gasoline engine, as of 1.12.2009 with 4- and 8-cylinder diesel engine and AMG, RHD
- 3 Power supply battery with 6-cylinder diesel engine, up to 30.11.2009 with 4- and 8-cylinder diesel engine and AMG
- 4 Additional battery ECO Start-Stopp

Legend

	Airbag		Structural reinforcements		Battery
	Gas generator		Rollover protection		High-voltage components
	Seat belt tensioner		Fuel tank		Cutting points
	Gas filled spring device		Control unit		

**E-Class
Sedan
Model 123**

1975-1986

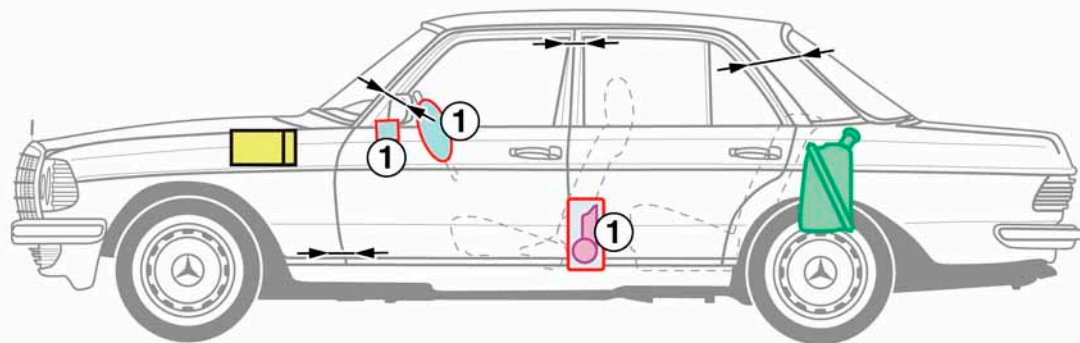
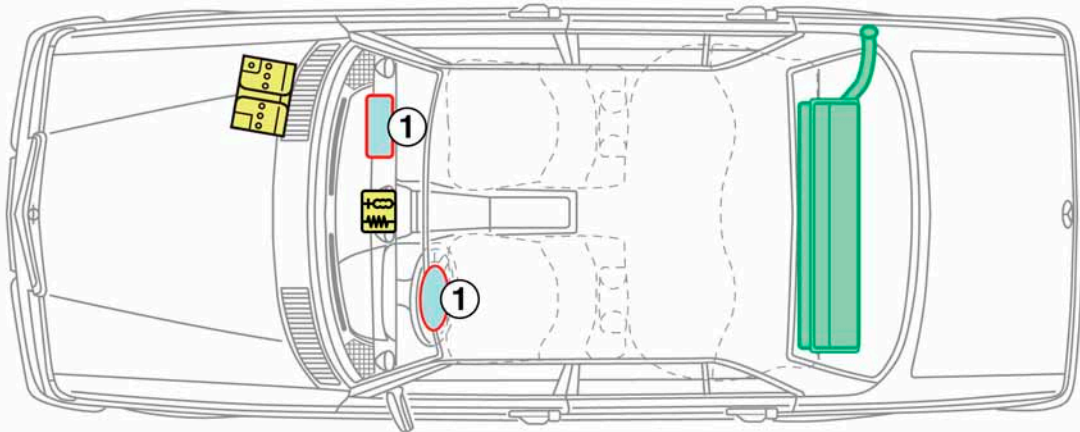

1 as of 1980

Legend



Airbag



Structural reinforcements

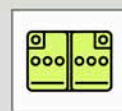

Battery



Gas generator



Rollover protection



High-voltage components



Seat belt tensioner



Fuel tank



Cutting points

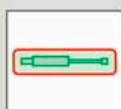

Gas filled spring device



Control unit

**E-Class
Sedan
Model 124**

1984-1995

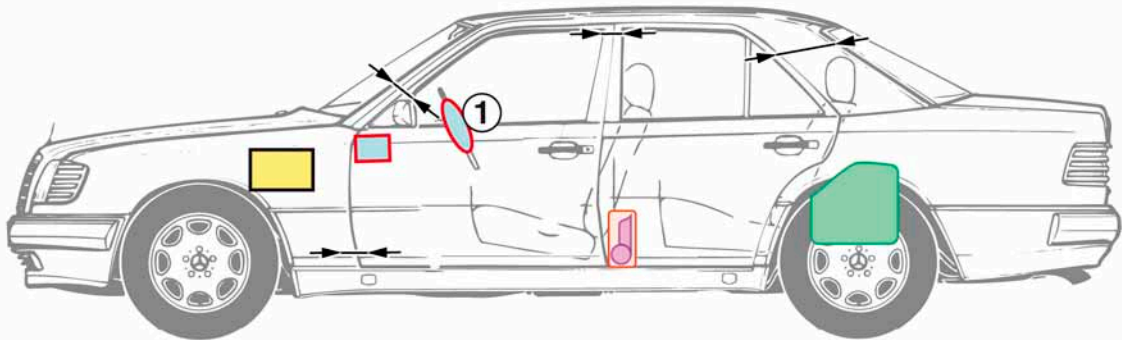
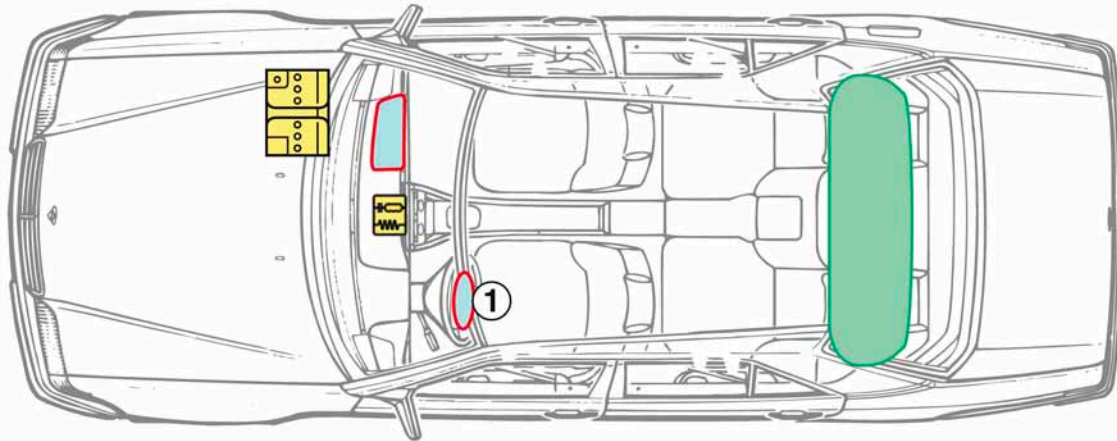

1 Standard as of 1992

Legend



Airbag



Structural reinforcements

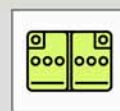

Battery



Gas generator



Rollover protection



High-voltage components



Seat belt tensioner



Fuel tank



Cutting points

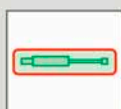

Gas filled spring device



Control unit

**E-Class
Sedan
Model 210**

1995-2002

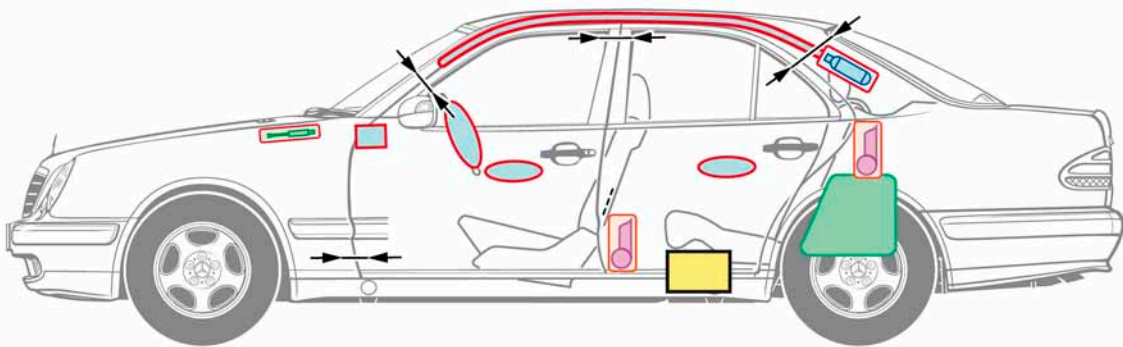
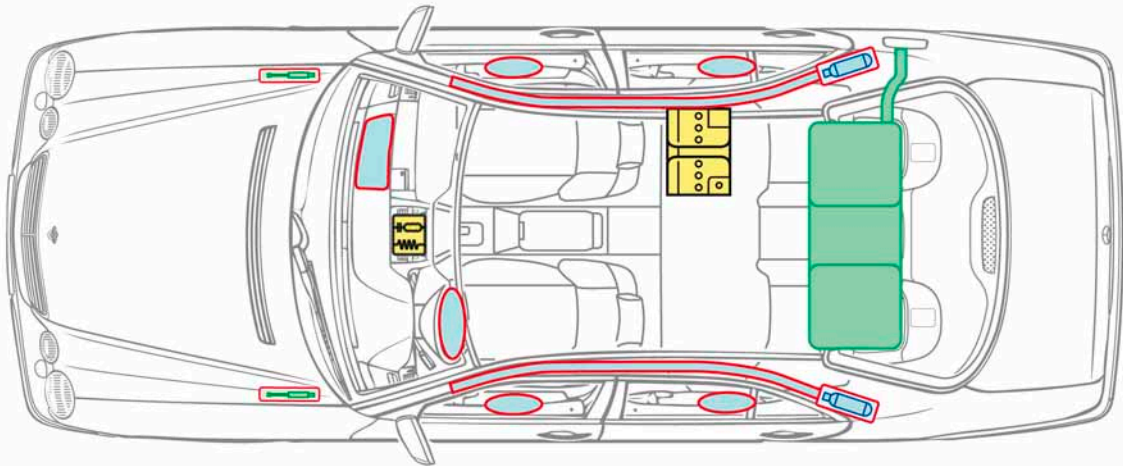

Legend



Airbag

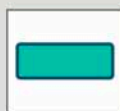

Structural reinforcements

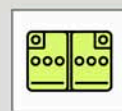

Battery



Gas generator



Rollover protection



High-voltage components



Seat belt tensioner



Fuel tank



Cutting points



Gas filled spring device



Control unit

**E-Class
Sedan
Model 211**

2002-2009

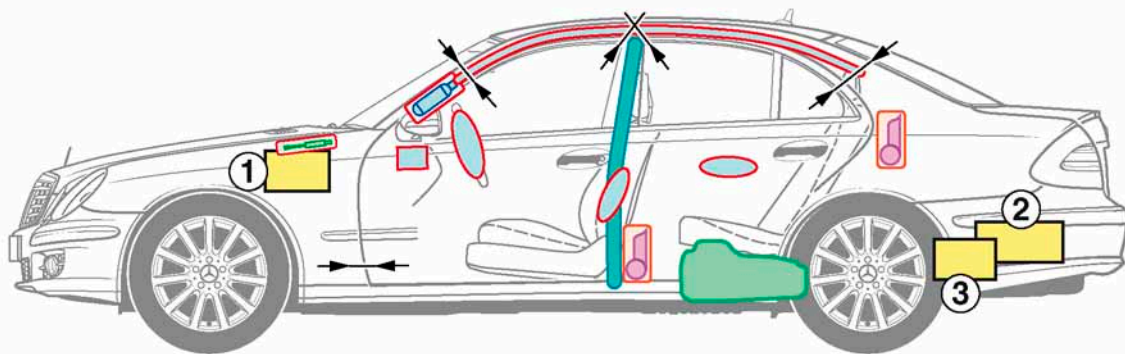
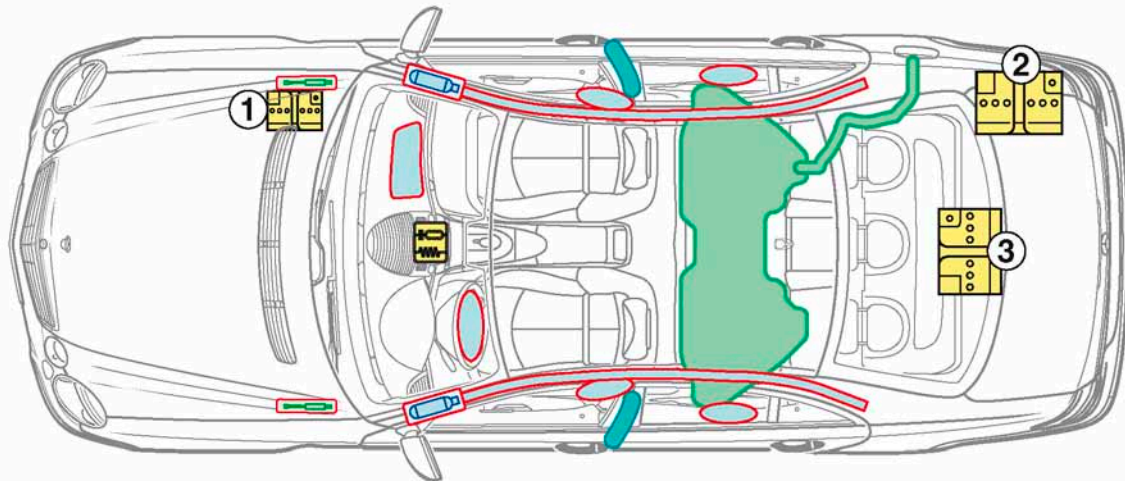

- 1 Additional battery (engine compartment)
- 2 Main battery (equipment with spare wheel)
- 3 Main battery (equipment without spare wheel)

Legend



Airbag



Structural reinforcements

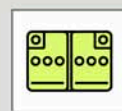

Battery



Gas generator



Rollover protection



High-voltage components



Seat belt tensioner



Fuel tank



Cutting points



Gas filled spring device



Control unit

**E-Class
NGT
Sedan
Model 211**

2004-2009

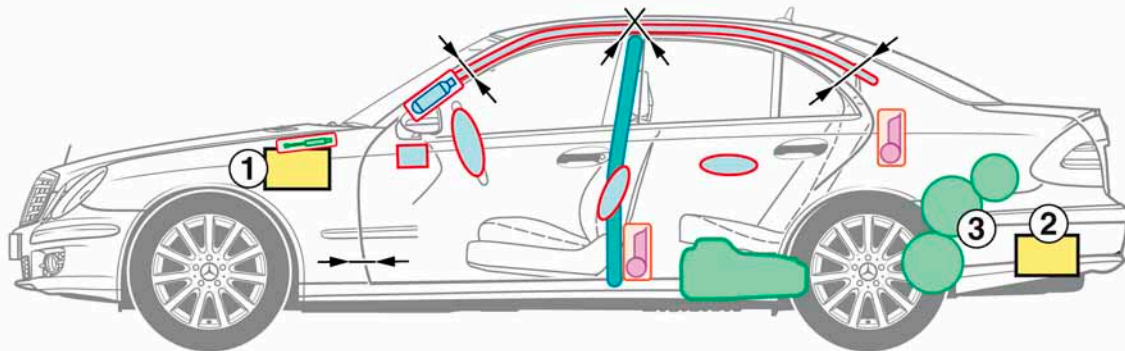
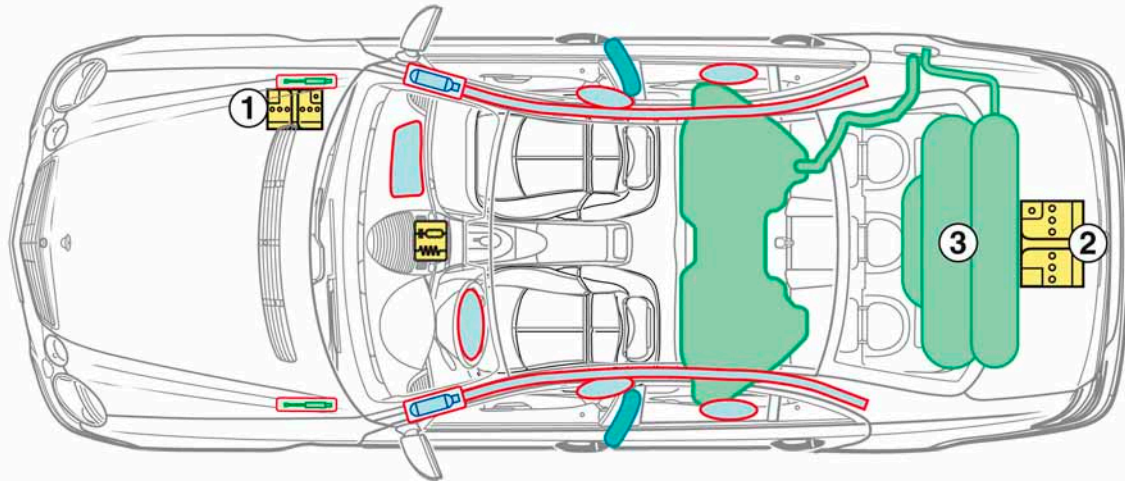

1 Additional battery (engine compartment)

2 Main battery (trunk)

3 Gas cylinder

Legend



Airbag



Structural reinforcements

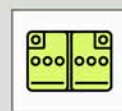

Battery



Gas generator



Rollover protection



High-voltage components



Seat belt tensioner



Fuel tank



Cutting points



Gas filled spring device



Control unit





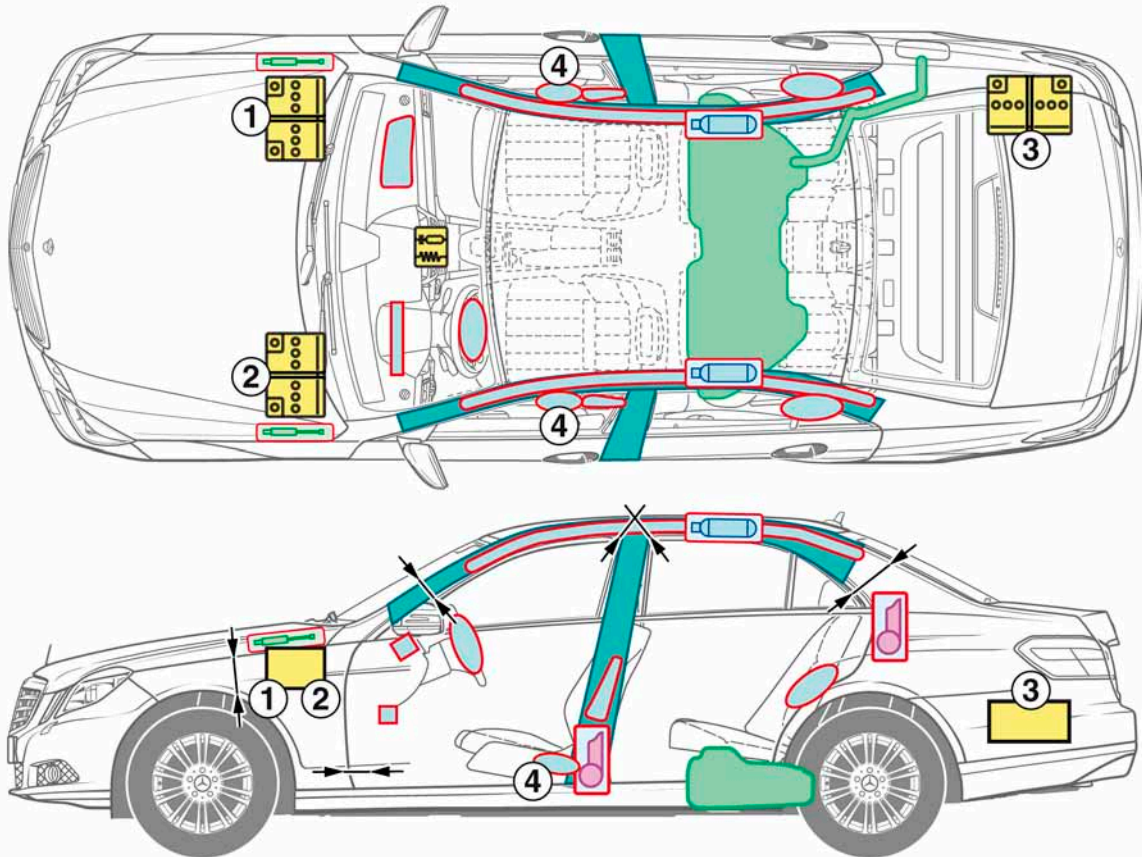

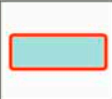

**E-Class
Sedan
Model 212**

as of 2009

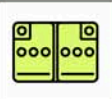

- 1 LHD, with 4- and 6-cylinder engine, 8-cylinder engine as of MY 2011
- 2 RHD, with 4- and 6-cylinder engine, 8-cylinder engine as of MY 2011
- 3 with 8-cylinder engine (up to MY 2011)
- 4 Pelvisbag (as of 06.2009)

Legend

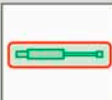
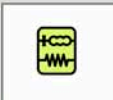
	Airbag		Structural reinforcements		Battery
	Gas generator		Rollover protection		High-voltage components
	Seat belt tensioner		Fuel tank		Cutting points
	Gas filled spring device		Control unit		





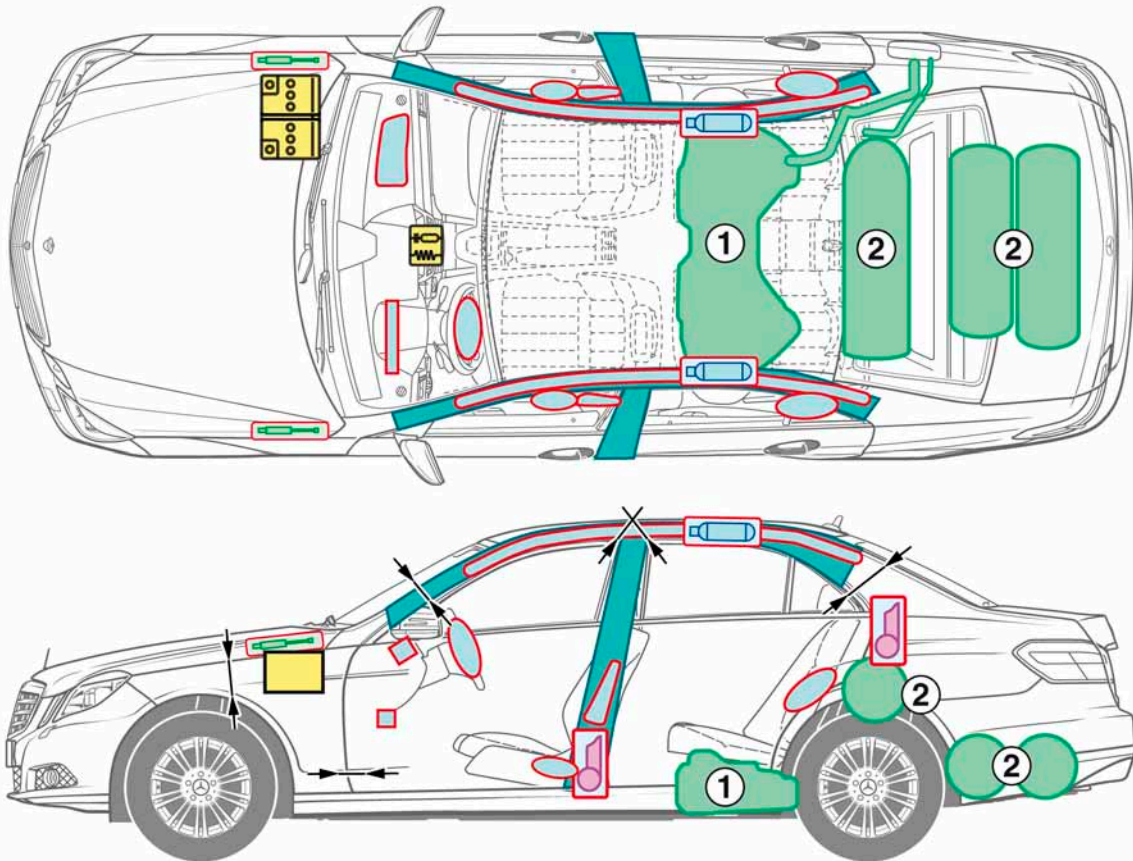



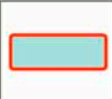

**E-Class
NGT
Sedan**

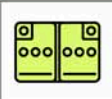
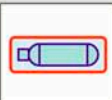
**Model 212
as of 2010**



- 1 Fuel tank
- 2 Gas cylinder

Legend

	Airbag		Structural reinforcements		Battery
	Gas generator		Rollover protection		High-voltage components
	Seat belt tensioner		Fuel tank		Cutting points
	Gas filled spring device		Control unit		





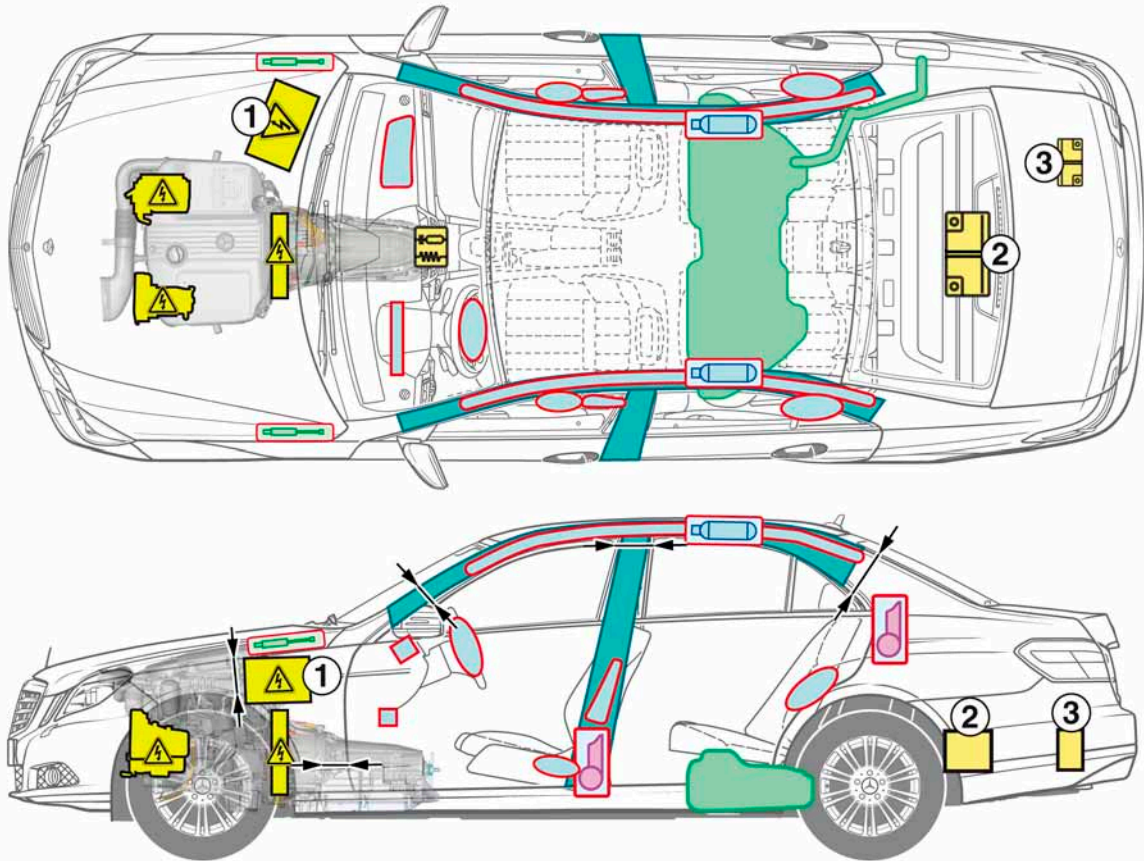



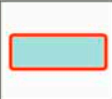

**E-Class
HYBRID
Sedan
Model 212**

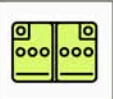
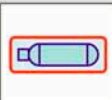
as of 2012



- 1 High-voltage battery
- 2 Power supply battery
- 3 Additional battery ECO Start-Stopp

Legend

	Airbag		Structural reinforcements		Battery
	Gas generator		Rollover protection		High-voltage components
	Seat belt tensioner		Fuel tank		Cutting points
	Gas filled spring device		Control unit		

**S-Class
Sedan
Model 116**

1972-1980

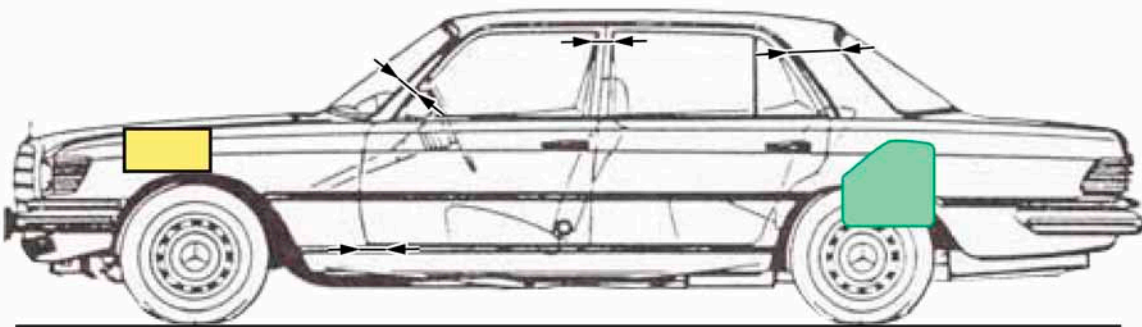
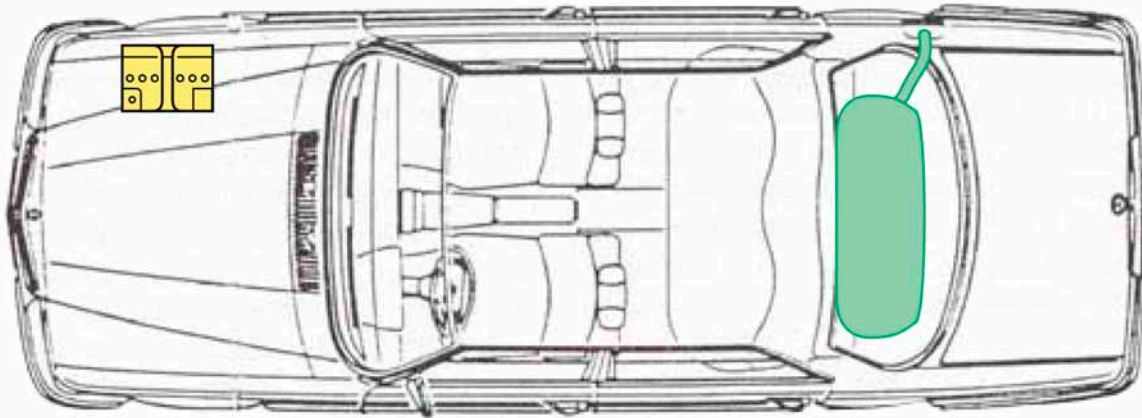

Legend



Airbag



Structural reinforcements

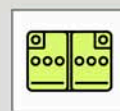

Battery



Gas generator



Rollover protection



High-voltage components



Seat belt tensioner



Fuel tank



Cutting points



Gas filled spring device



Control unit

**S-Class
Sedan
Model 126**

1979-1991

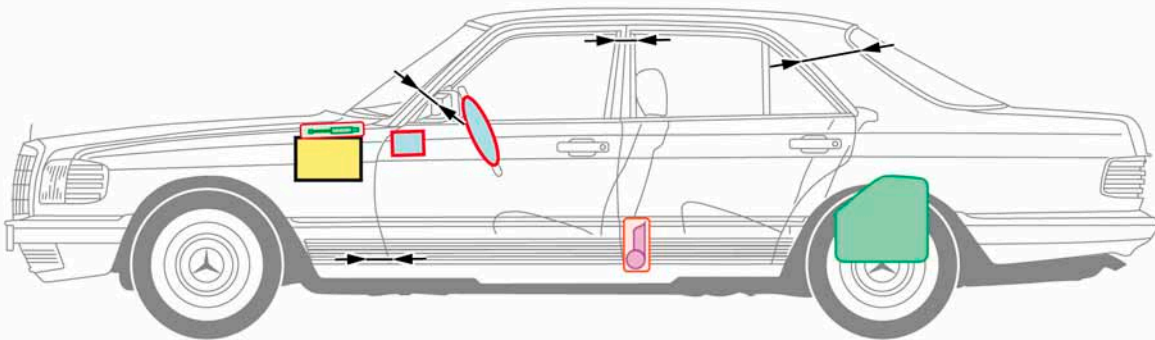
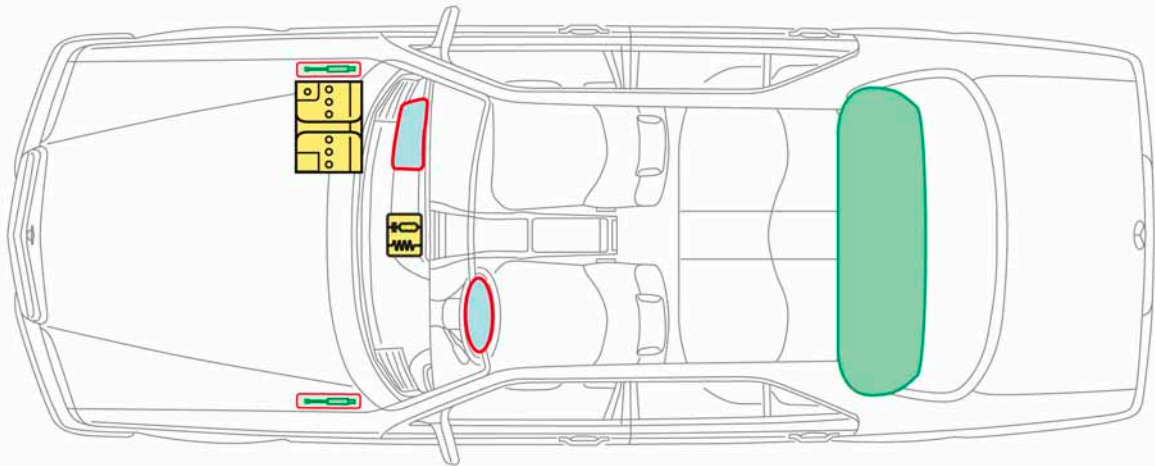

Legend



Airbag

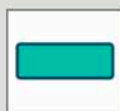

Structural reinforcements

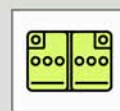

Battery



Gas generator



Rollover protection



High-voltage components



Seat belt tensioner



Fuel tank



Cutting points



Gas filled spring device



Control unit

**S-Class
Sedan
Model 140**

1991-1998

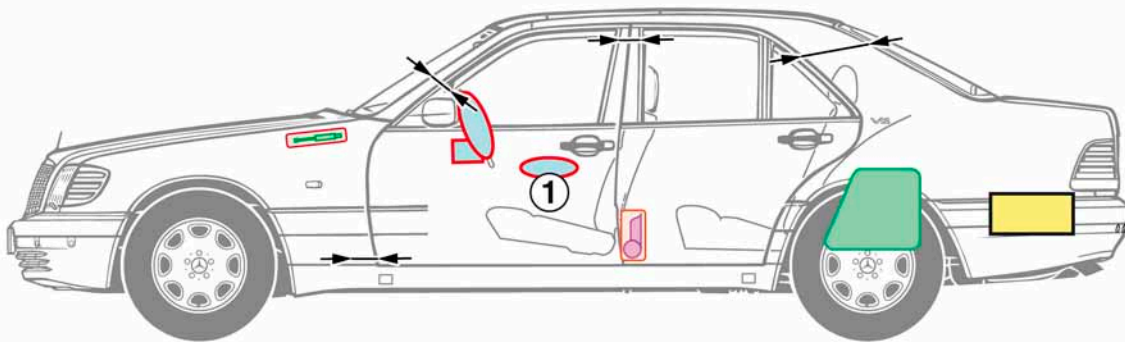
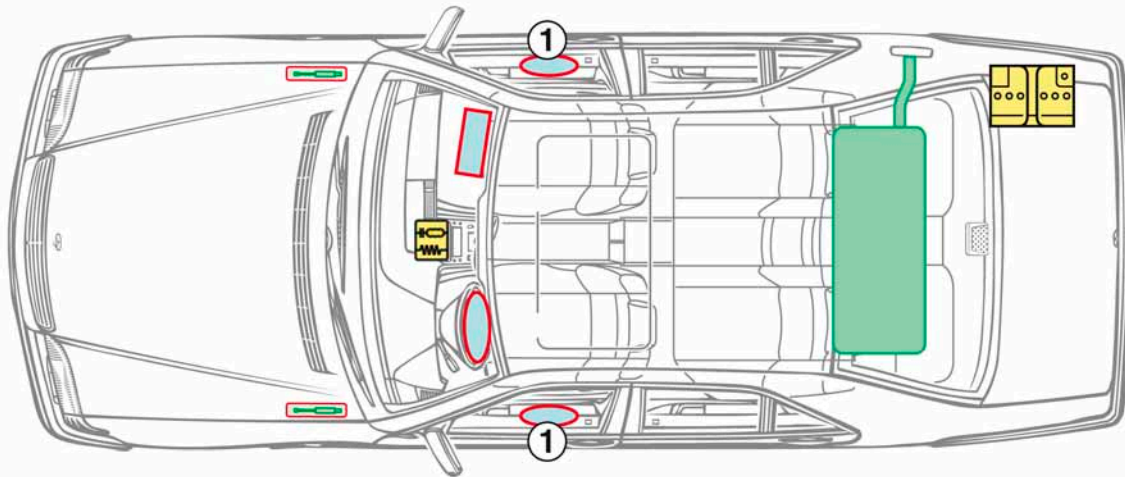

1 Special equipment

Legend



Airbag



Structural reinforcements

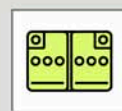

Battery



Gas generator



Rollover protection



High-voltage components



Seat belt tensioner



Fuel tank



Cutting points



Gas filled spring device



Control unit

**S-Class
Pullman
Sedan
Model 140**

1996-2000

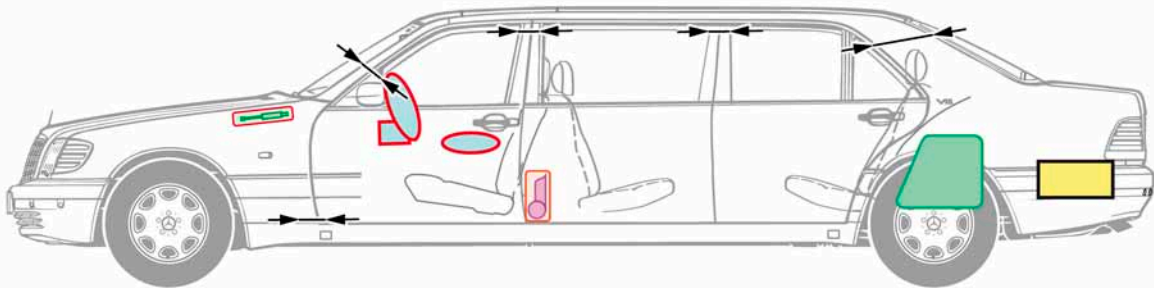
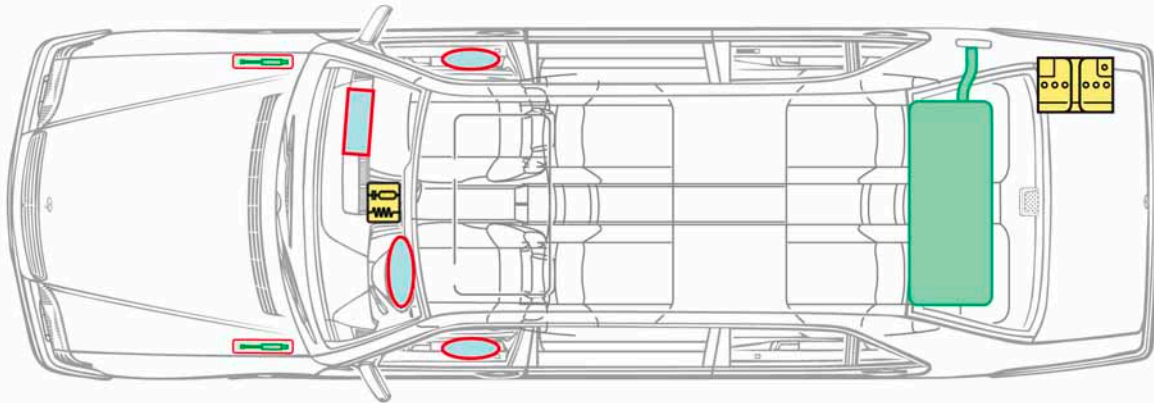

Legend



Airbag



Structural reinforcements

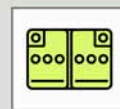

Battery



Gas generator



Rollover protection



High-voltage components



Seat belt tensioner



Fuel tank



Cutting points



Gas filled spring device









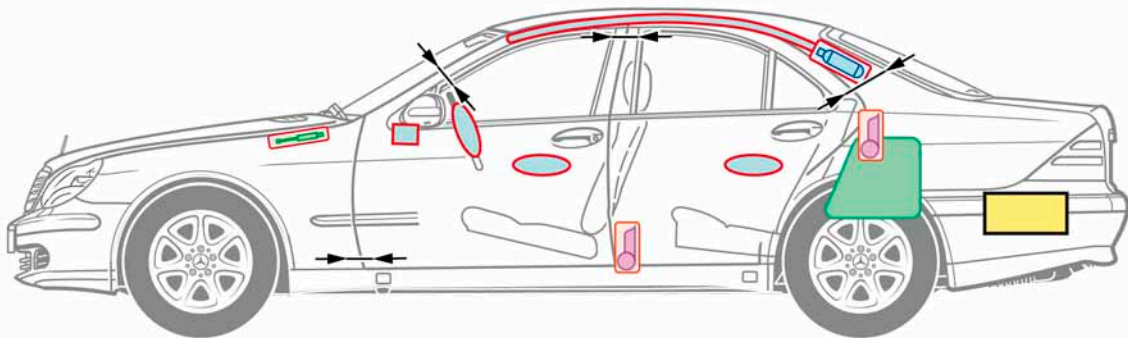
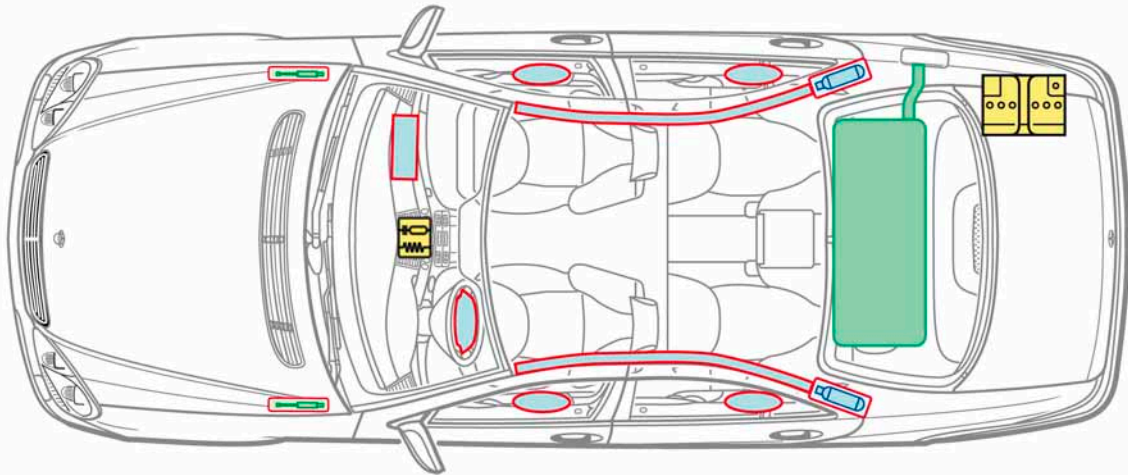

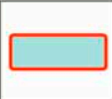

Control unit

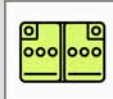
**S-Class
Sedan
Model 220**

1998-2005



Legend

	Airbag		Structural reinforcements		Battery
	Gas generator		Rollover protection		High-voltage components
	Seat belt tensioner		Fuel tank		Cutting points
	Gas filled spring device		Control unit		

**S-Class
Pullman
Sedan
Model 220**

2000-2005

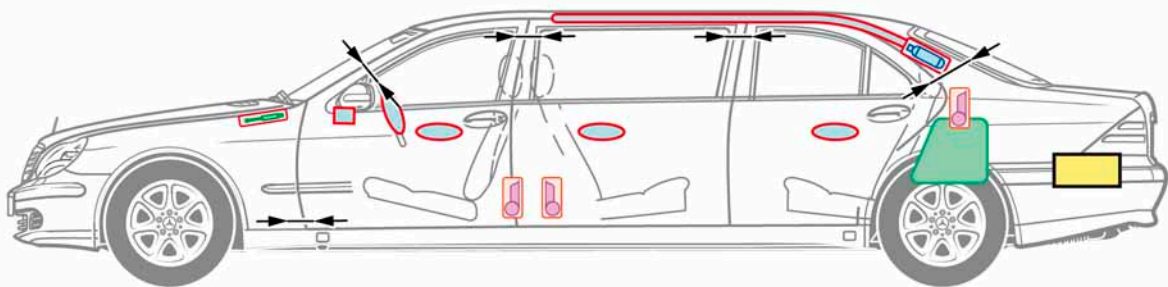
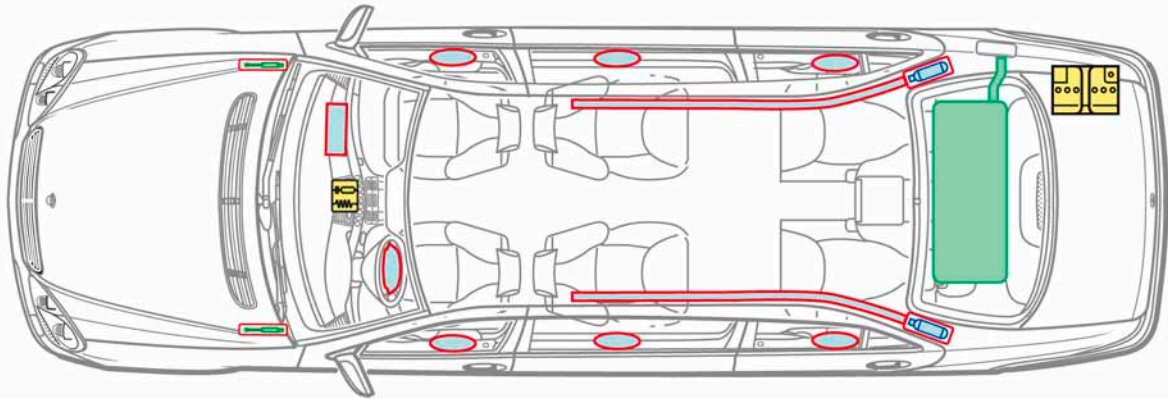

Legend



Airbag

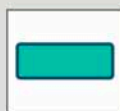

Structural reinforcements

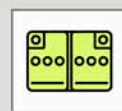

Battery



Gas generator



Rollover protection



High-voltage components



Seat belt tensioner



Fuel tank



Cutting points



Gas filled spring device



Control unit





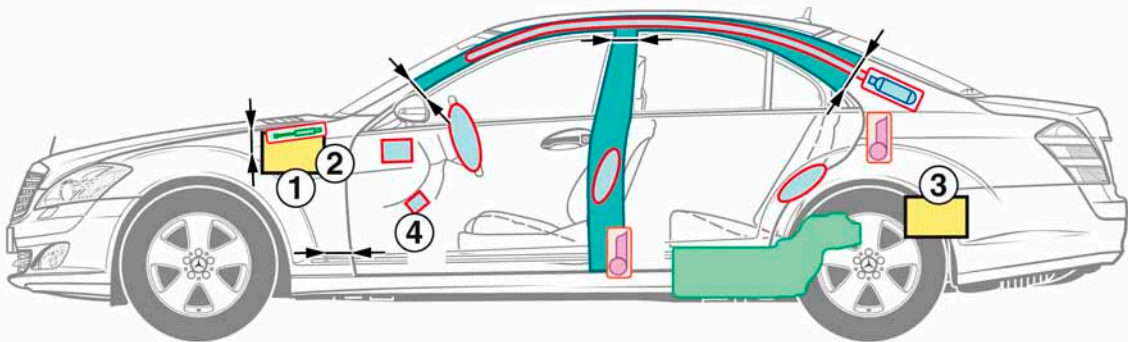
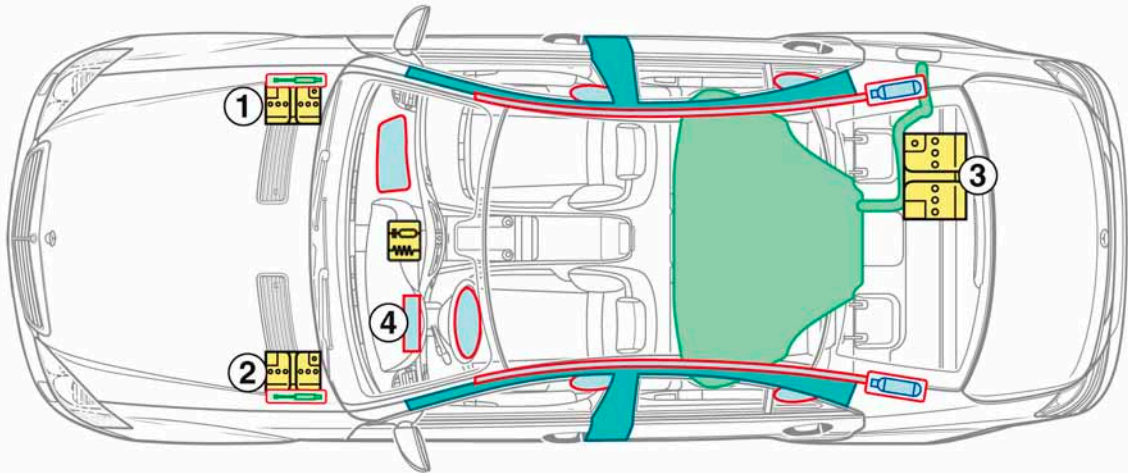



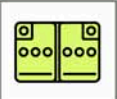

**S-Class
Sedan
Model 221**

as of 2005



- 1 Battery (engine compartment, LHD)
- 2 Battery (engine compartment, RHD)
- 3 Battery trunk (up to 08.2008)
- 4 Knee bag driver (as of 09.2008)

Legend

	Airbag		Structural reinforcements		Battery
	Gas generator		Rollover protection		High-voltage components
	Seat belt tensioner		Fuel tank		Cutting points
	Gas filled spring device		Control unit		

**S-Class
HYBRID
Sedan
Model 221**

as of 2009

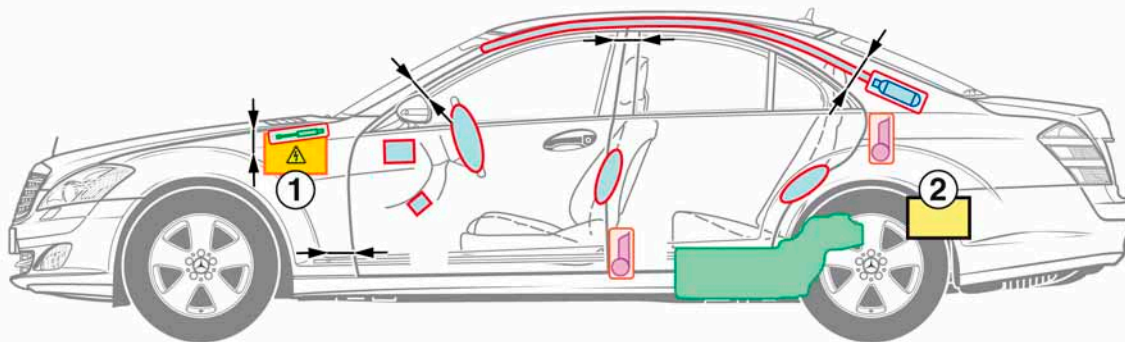
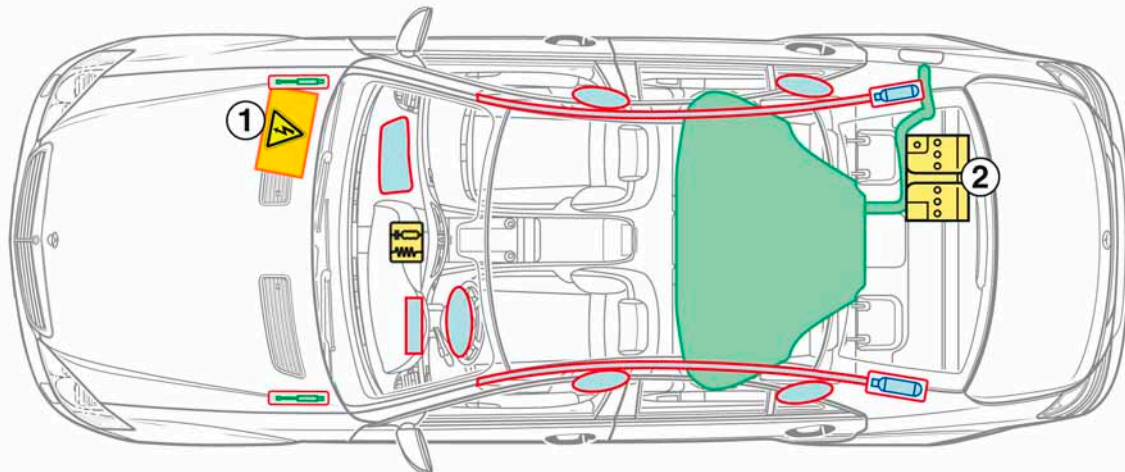

- 1 High-voltage battery (engine compartment)
- 2 Power supply battery (trunk)

Legend



Airbag



Structural reinforcements

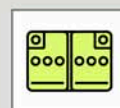

Battery



Gas generator



Rollover protection



High-voltage components



Seat belt tensioner



Fuel tank



Cutting points



Gas filled spring device



Control unit

**C-Class
T-Model
Model 202**

1996-2001

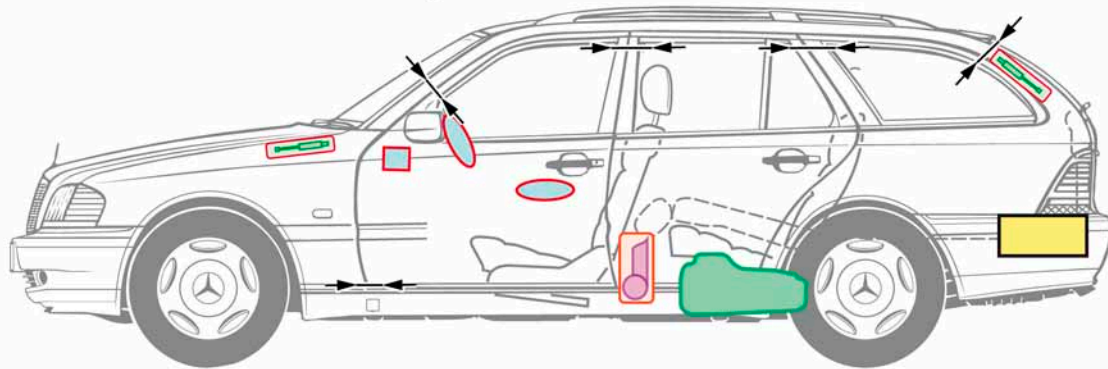
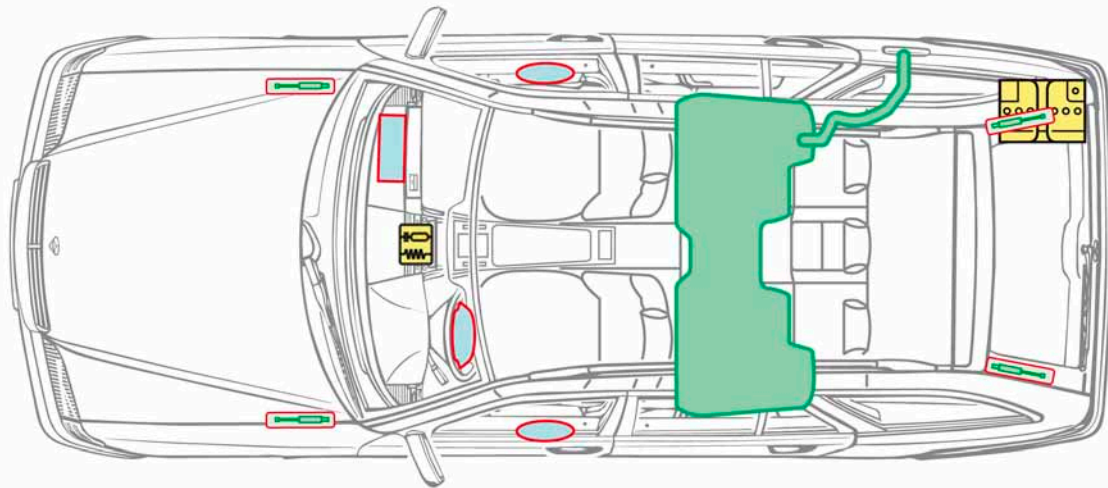

Legend



Airbag



Structural reinforcements

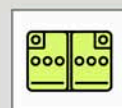

Battery



Gas generator



Rollover protection



High-voltage components



Seat belt tensioner



Fuel tank



Cutting points



Gas filled spring device



Control unit

**C-Class
T-Model
Model 203**

2001-2007

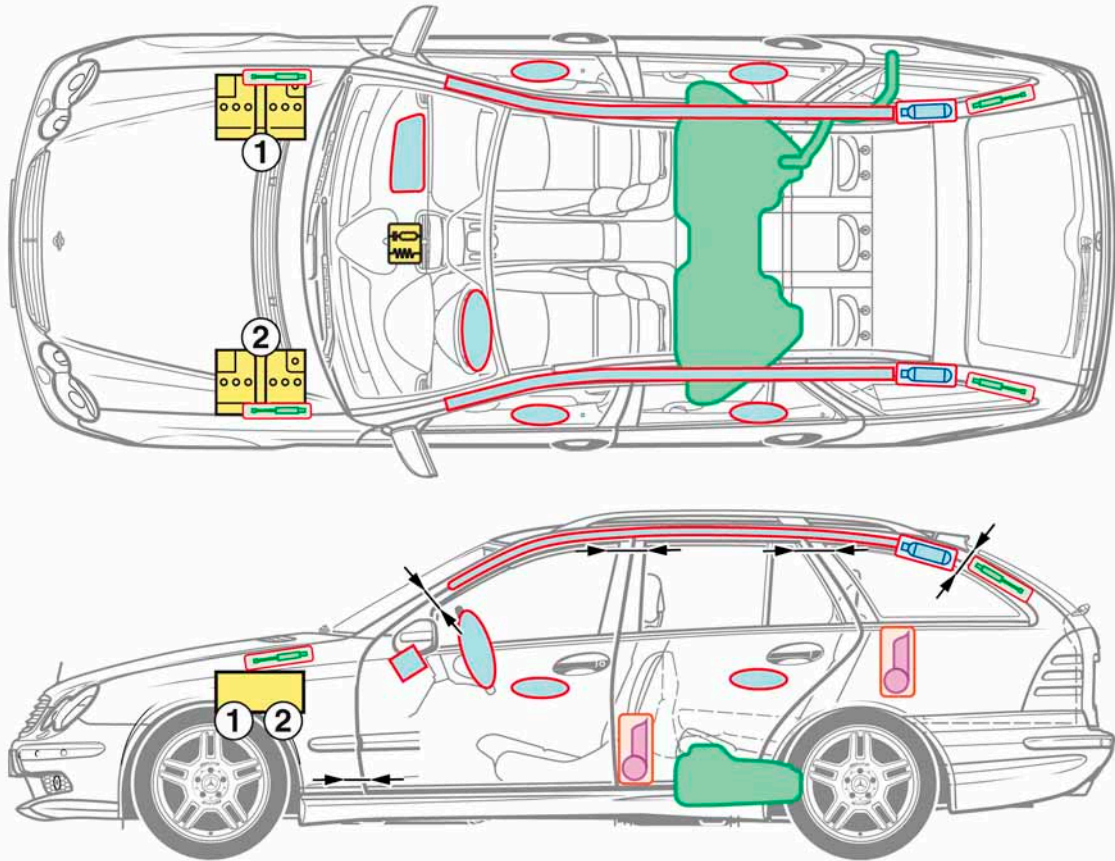

1 LHD vehicle
2 RHD vehicle

Legend

	Airbag		Structural reinforcements		Battery
	Gas generator		Rollover protection		High-voltage components
	Seat belt tensioner		Fuel tank		Cutting points
	Gas filled spring device		Control unit		

**C-Class
T-Model
Model 204**

as of 2007

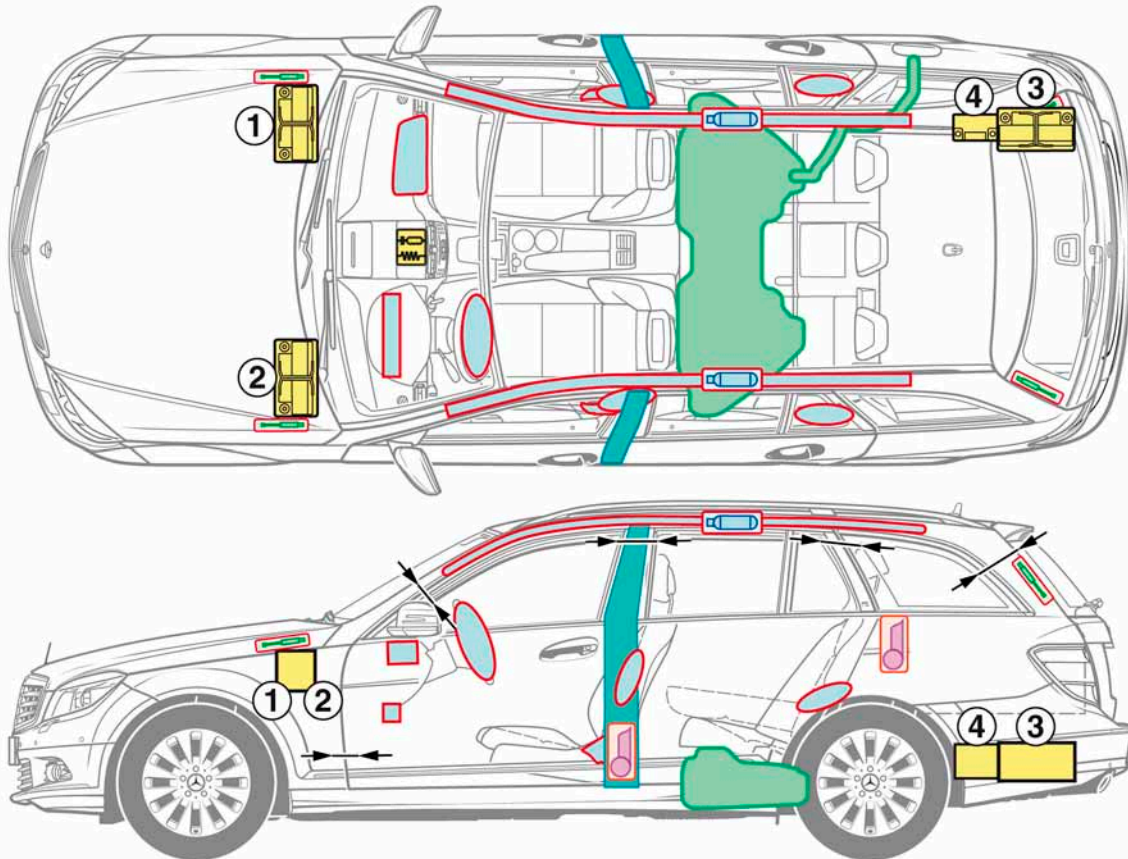

- 1 Power supply battery with gasoline engine, as of 1.12.2009 with 4- and 8-cylinder diesel engine and AMG, LHD
- 2 Power supply battery with gasoline engine, as of 1.12.2009 with 4- and 8-cylinder diesel engine and AMG, RHD
- 3 Power supply battery with 6-cylinder diesel engine, up to 30.11.2009 with 4- and 8-cylinder diesel engine and AMG
- 4 Additional battery ECO Start-Stopp

Legend

	Airbag		Structural reinforcements		Battery
	Gas generator		Rollover protection		High-voltage components
	Seat belt tensioner		Fuel tank		Cutting points
	Gas filled spring device		Control unit		

**E-Class
T-Model
Model 123**

1977-1986

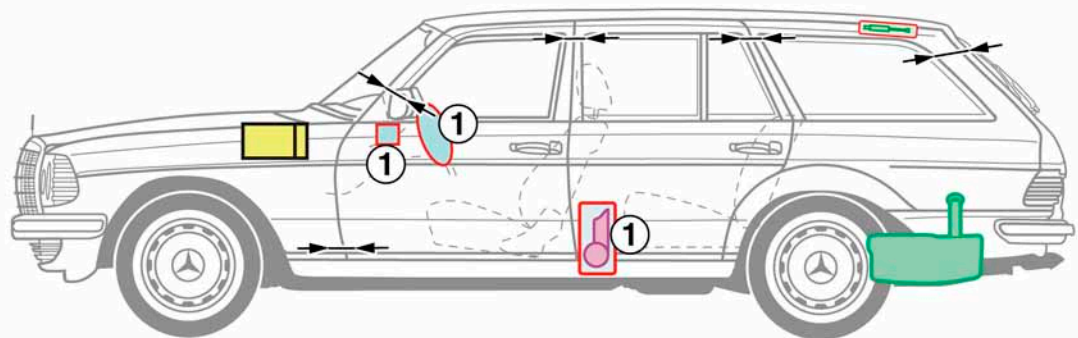
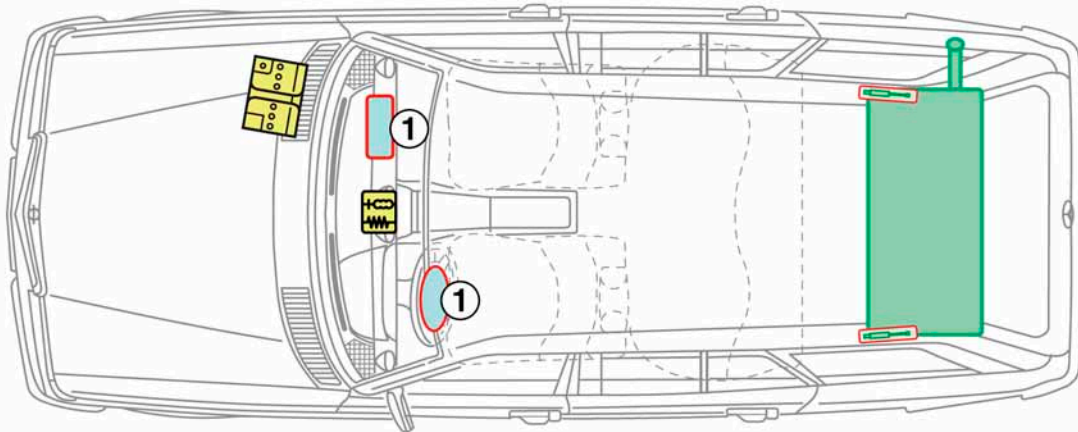

1 as of 1980

Legend



Airbag



Structural reinforcements

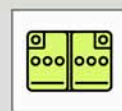

Battery

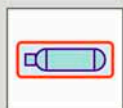

Gas generator



Rollover protection



High-voltage components



Seat belt tensioner



Fuel tank



Cutting points



Gas filled spring device



Control unit

**E-Class
T-Model
Model 124**

1984-1996

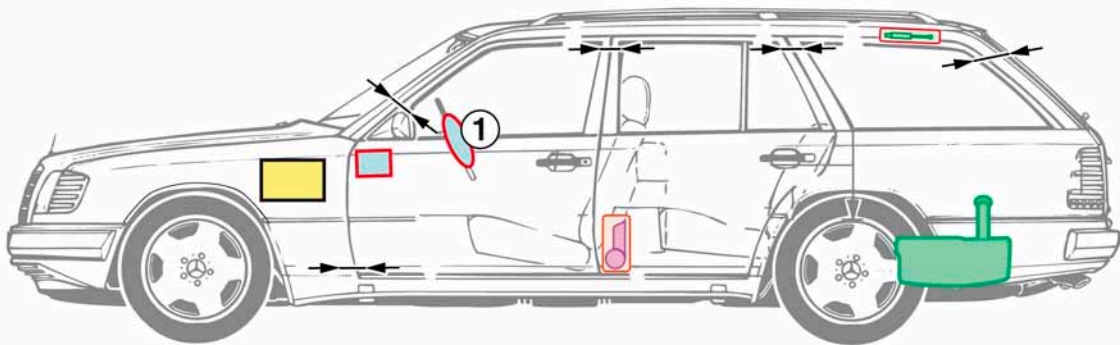
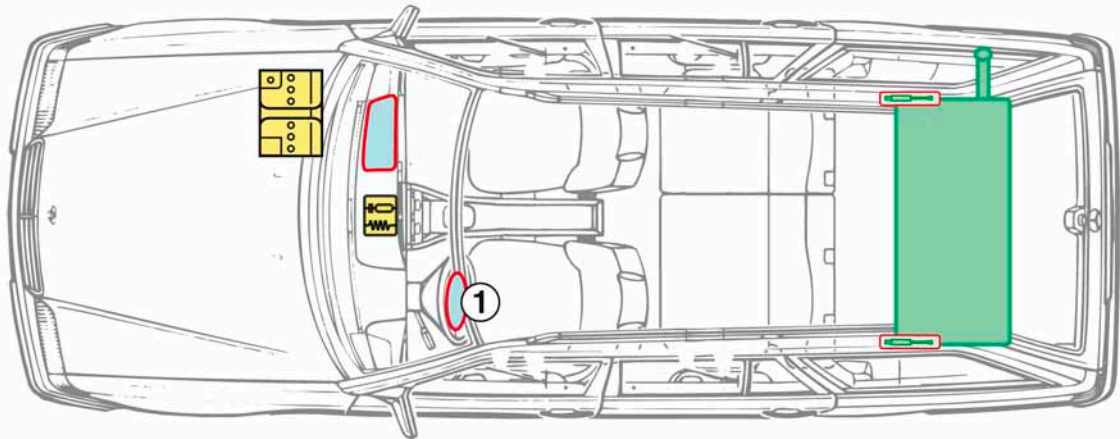

1 Standard as of 1992

Legend



Airbag



Structural reinforcements

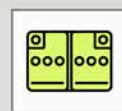

Battery

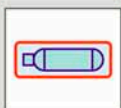

Gas generator



Rollover protection



High-voltage components



Seat belt tensioner



Fuel tank



Cutting points



Gas filled spring device



Control unit

**E-Class
T-Model
Model 210**

1996-2003

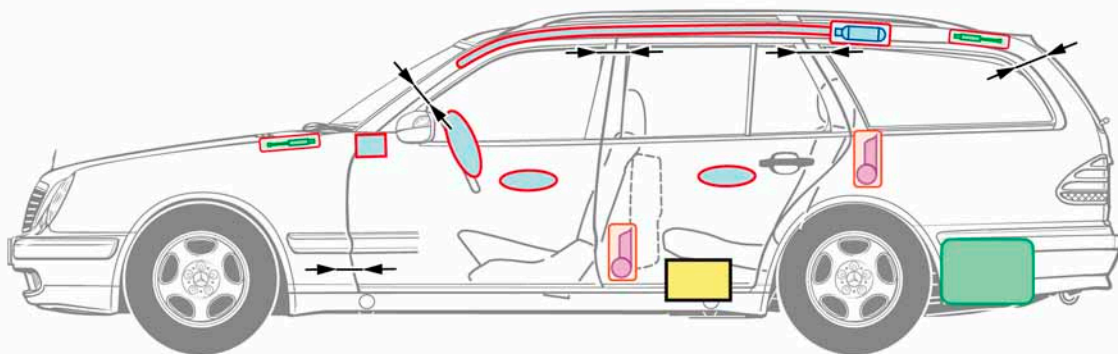
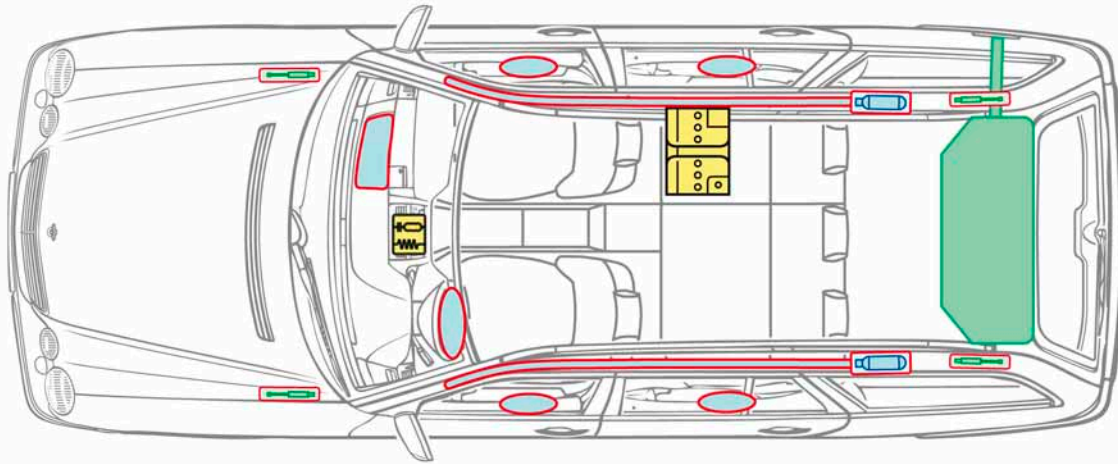

Legend



Airbag

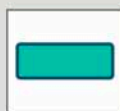

Structural reinforcements

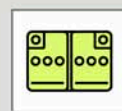

Battery



Gas generator



Rollover protection



High-voltage components



Seat belt tensioner



Fuel tank



Cutting points



Gas filled spring device



Control unit





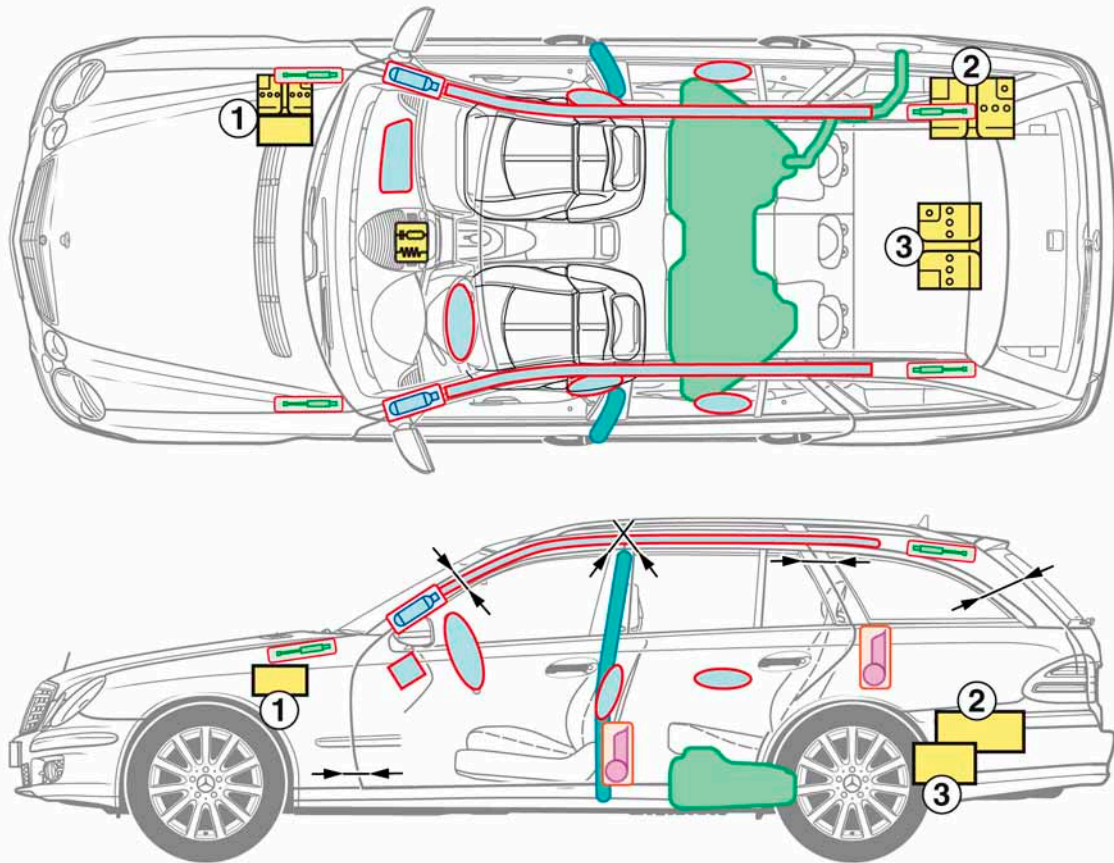



**E-Class
T-Model
Model 211**

2003-2009

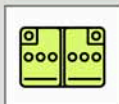
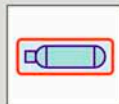

- 1 Additional battery (engine compartment)
- 2 Main battery (equipment with spare wheel)
- 3 Main battery (equipment without spare wheel)

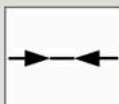
Legend

	Airbag		Structural reinforcements		Battery
	Gas generator		Rollover protection		High-voltage components
	Seat belt tensioner		Fuel tank		Cutting points
	Gas filled spring device		Control unit		





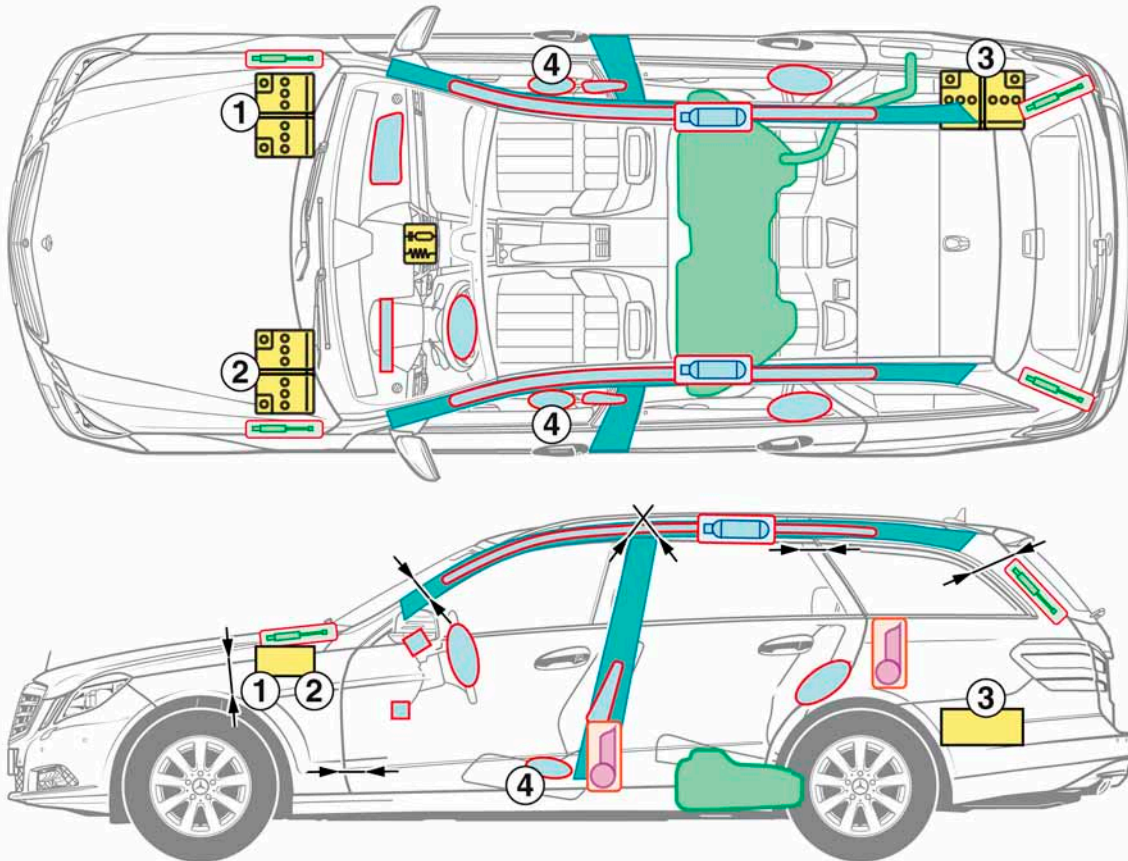



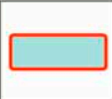

**E-Class
T-Model
Model 212**

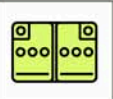
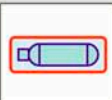
as of 2009



- 1 LHD, with 4- and 6-cylinder engine, 8-cylinder engine as of MY 2011
- 2 RHD, with 4- and 6-cylinder engine, 8-cylinder engine as of MY 2011
- 3 with 8-cylinder engine (up to MY 2011)
- 4 Pelvisbag (as of 06.2009)

Legend

	Airbag		Structural reinforcements		Battery
	Gas generator		Rollover protection		High-voltage components
	Seat belt tensioner		Fuel tank		Cutting points
	Gas filled spring device		Control unit		





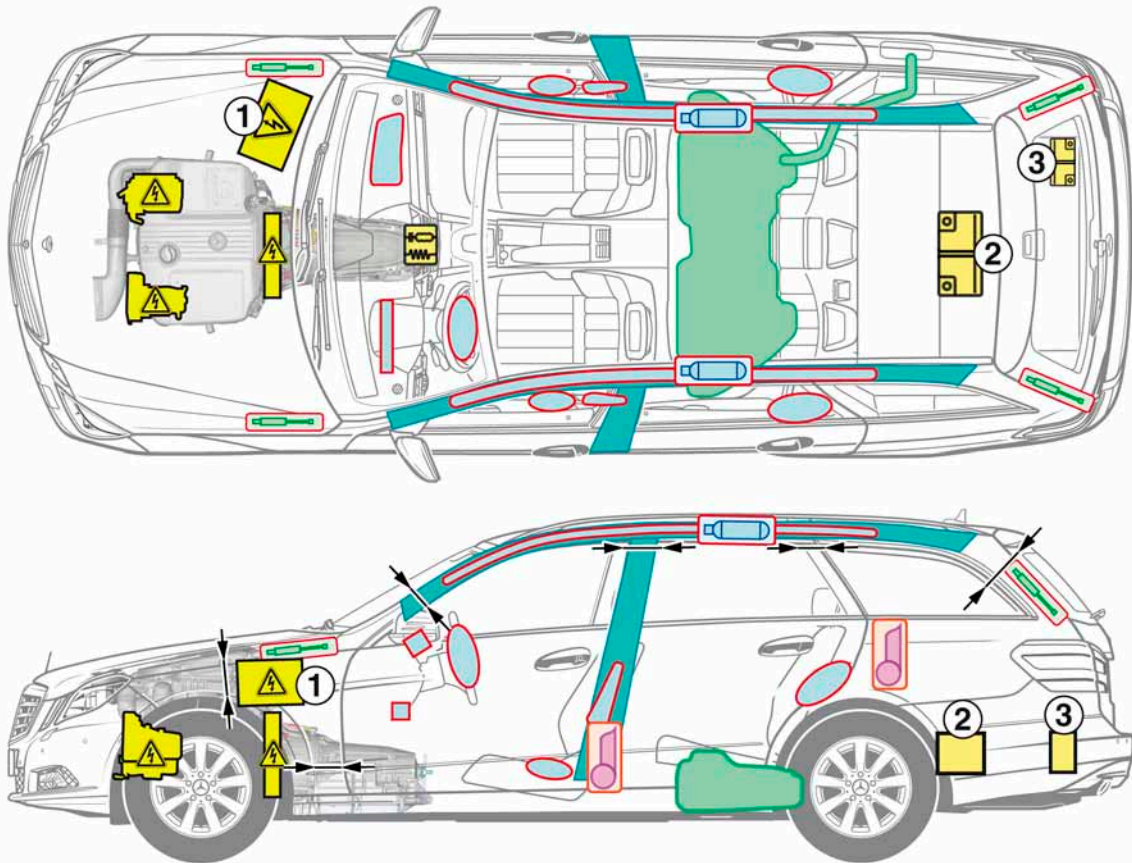



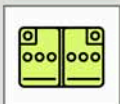

**E-Class
HYBRID
T-Model
Model 212**

as of 2012



- 1 High-voltage battery
- 2 Power supply battery
- 3 Additional battery ECO Start-Stop

Legend

	Airbag		Structural reinforcements		Battery
	Gas generator		Rollover protection		High-voltage components
	Seat belt tensioner		Fuel tank		Cutting points
	Gas filled spring device		Control unit		

**A-Class
Coupé
Model 169**

as of 2004

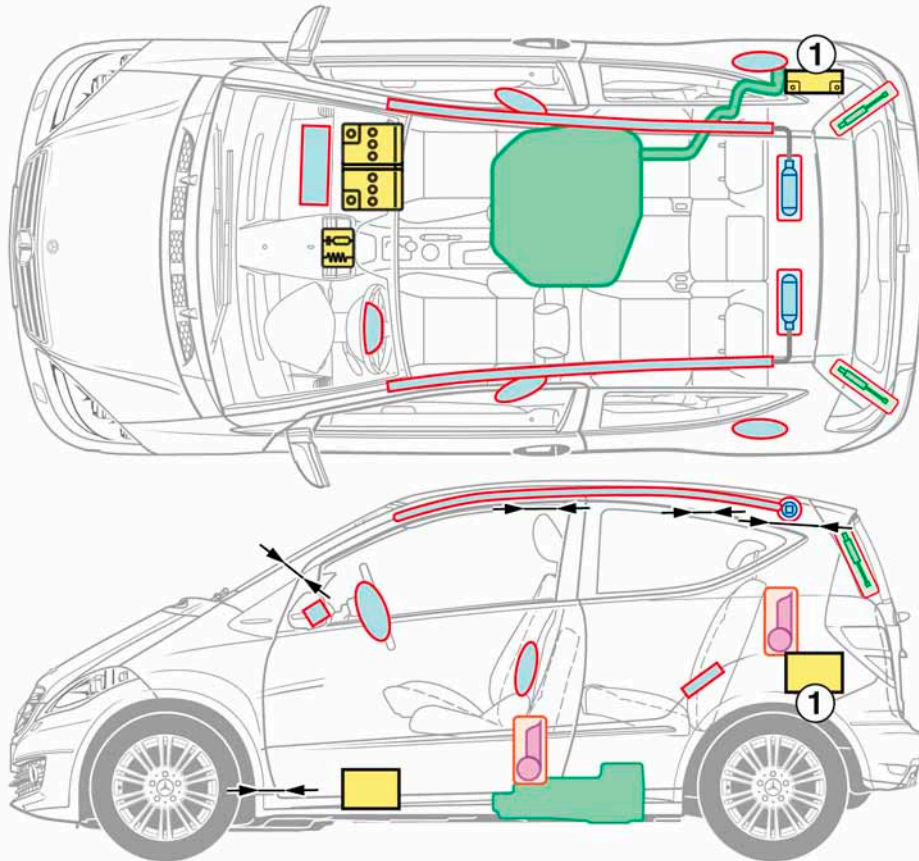

1 Additional battery BlueEFFICIENCY models

Legend



Airbag



Structural reinforcements

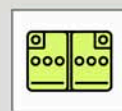

Battery



Gas generator



Rollover protection



High-voltage components



Seat belt tensioner



Fuel tank



Cutting points

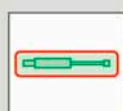

Gas filled spring device



Control unit

**C-Class
Sports coupé
Model 203**

2000-2008

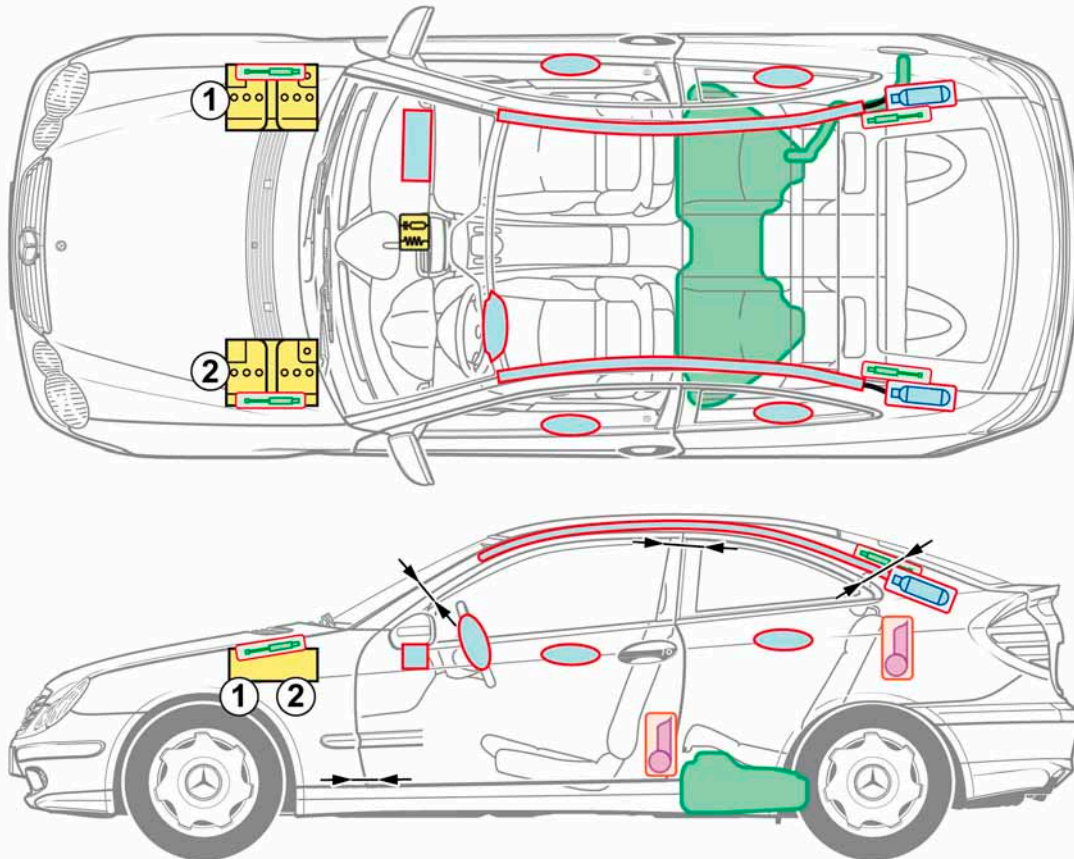

1 LHD vehicle
2 RHD vehicle

Legend



Airbag



Structural reinforcements

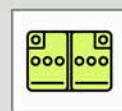

Battery



Gas generator



Rollover protection



High-voltage components



Seat belt tensioner



Fuel tank



Cutting points



Gas filled spring device



Control unit

**CLC-Class
Coupé
Model 203**

as of 2008

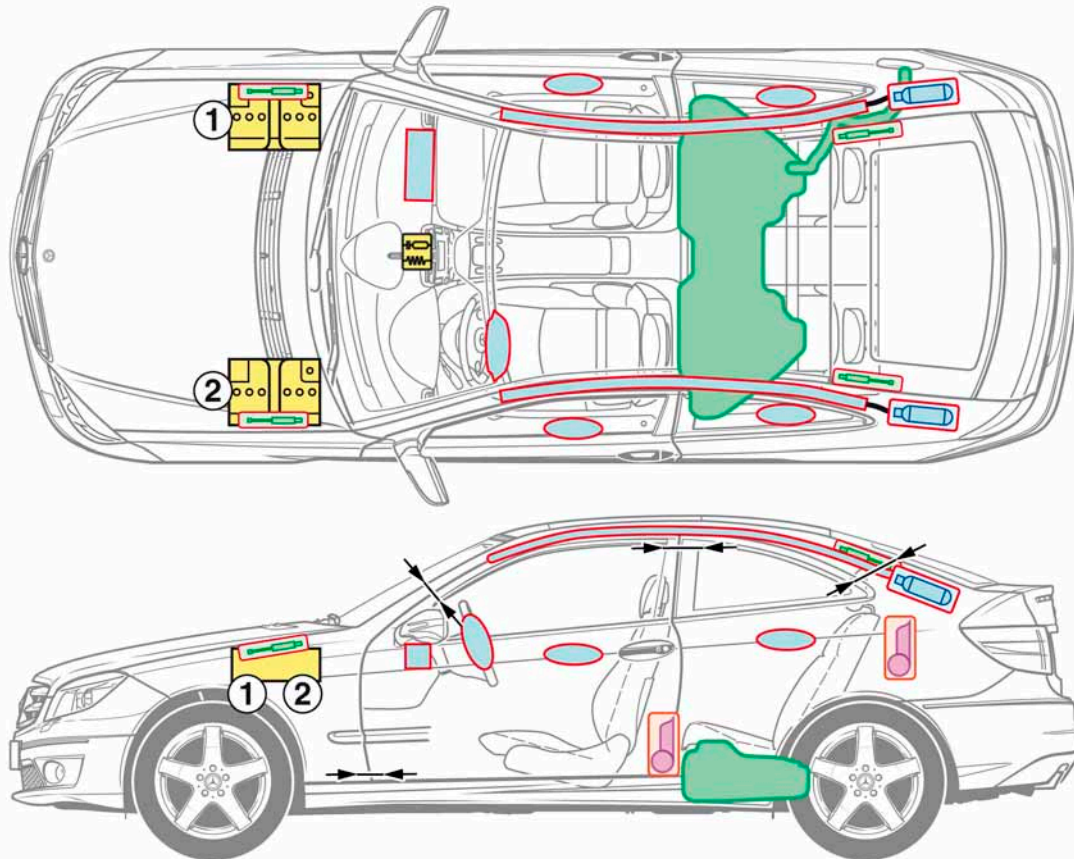

- 1 LHD vehicle
- 2 RHD vehicle

Legend



Airbag



Structural reinforcements

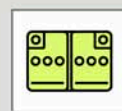

Battery



Gas generator



Rollover protection



High-voltage components



Seat belt tensioner



Fuel tank



Cutting points



Gas filled spring device



Control unit

**C-Class
Coupe
Model 204**

as of 2011

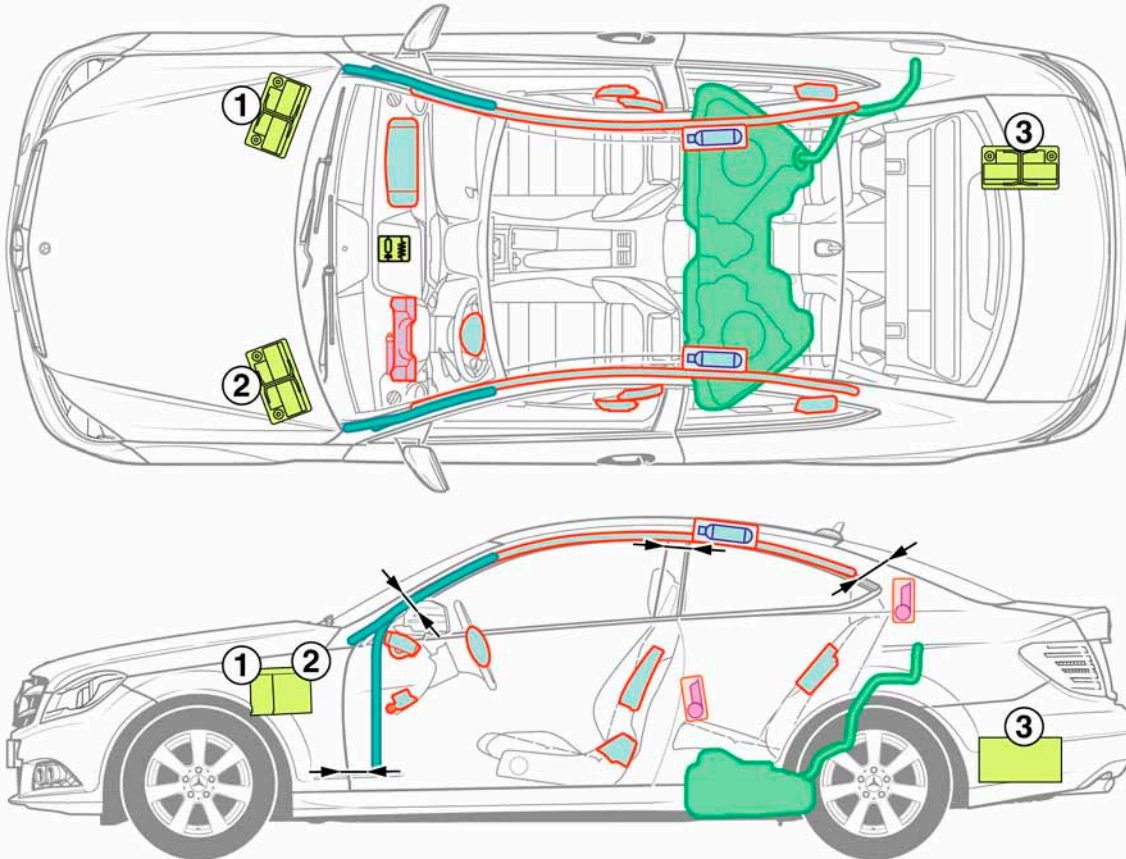

- 1 Power supply battery, LHD
- 2 Power supply battery, RHD
- 3 Additional battery

Legend



Airbag



Structural reinforcements

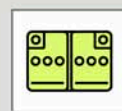

Battery



Gas generator



Rollover protection



High-voltage components

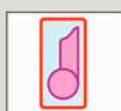

Seat belt tensioner



Fuel tank



Cutting points



Gas filled spring device



Control unit

**CLK-Class
Coupé
Model 208**

1997-2002

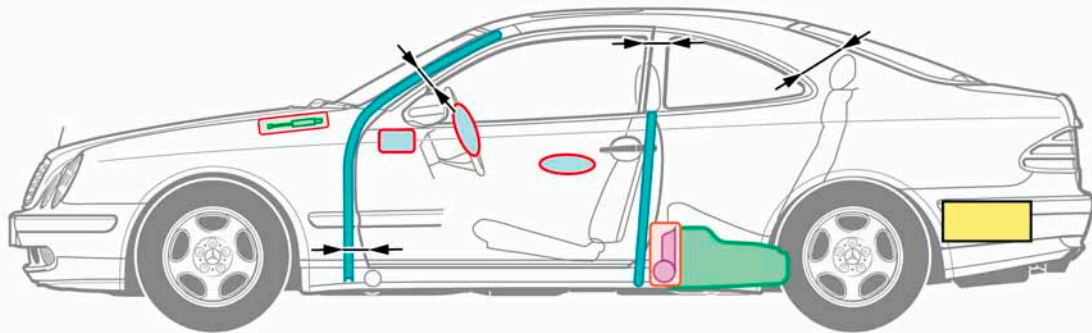
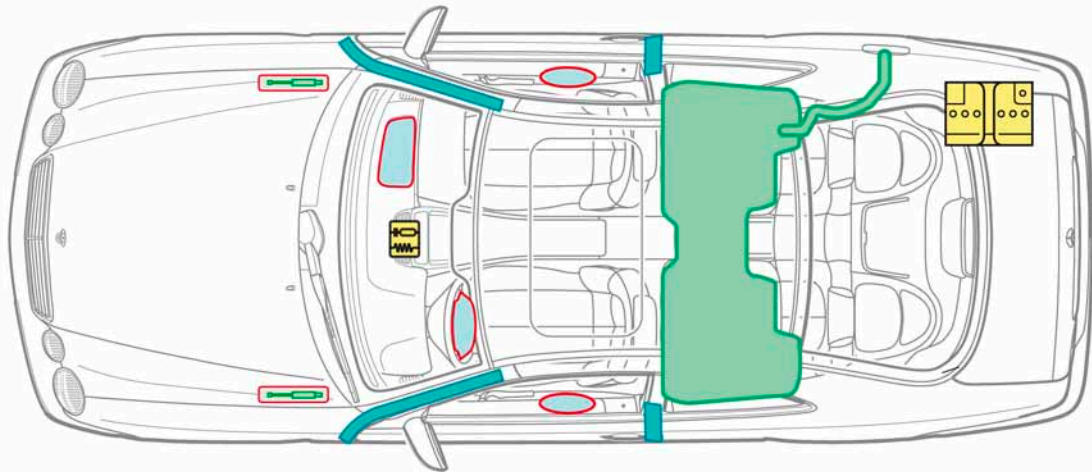

Legend



Airbag



Structural reinforcements

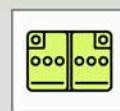

Battery



Gas generator



Rollover protection



High-voltage components



Seat belt tensioner



Fuel tank



Cutting points

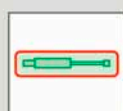

Gas filled spring device



Control unit

**CLK-Class
Coupé
Model 209**

2002-2009

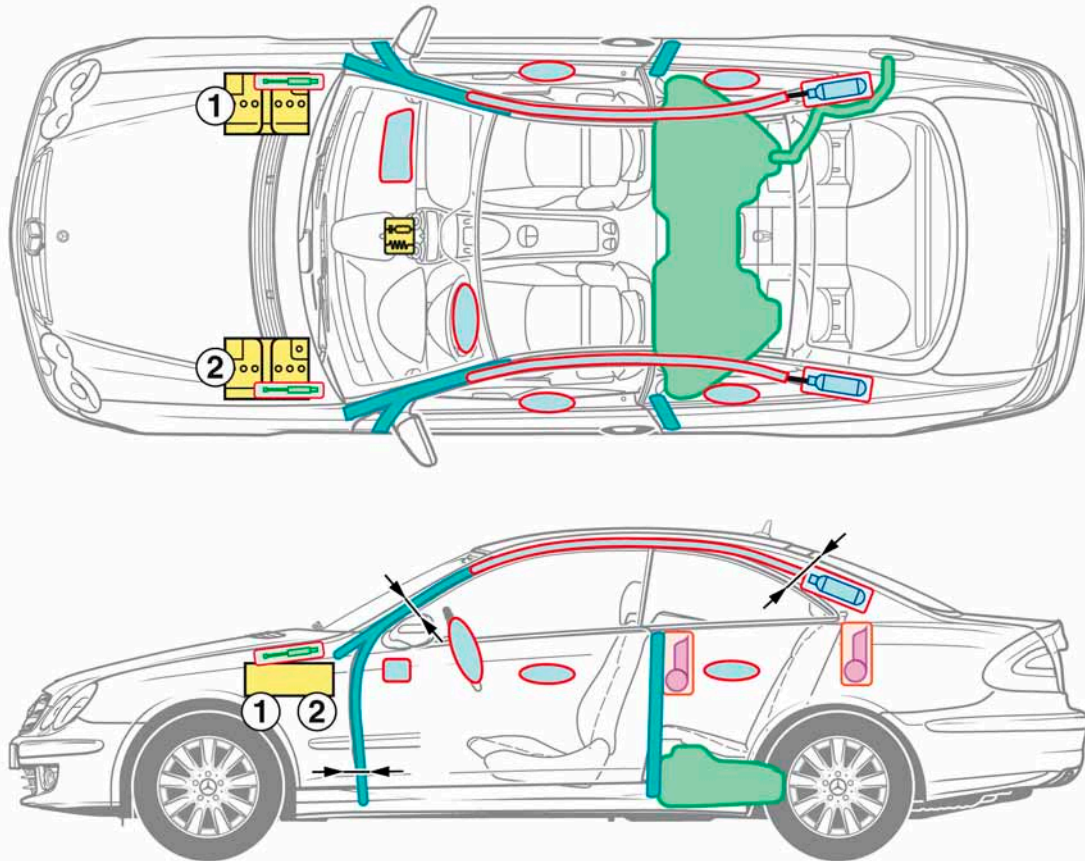

1 LHD vehicle
2 RHD vehicle

Legend



Airbag



Structural reinforcements

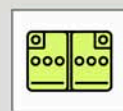

Battery

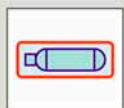

Gas generator



Rollover protection



High-voltage components



Seat belt tensioner



Fuel tank



Cutting points



Gas filled spring device



Control unit

**CL-Class
Coupé
Model 215**

1999-2006

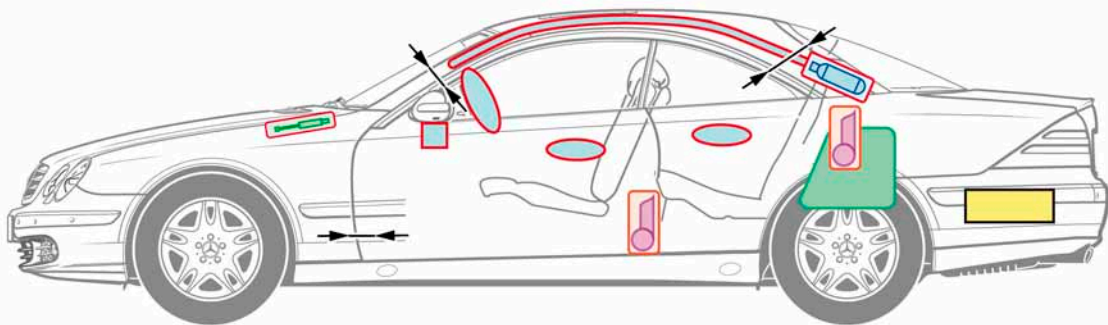
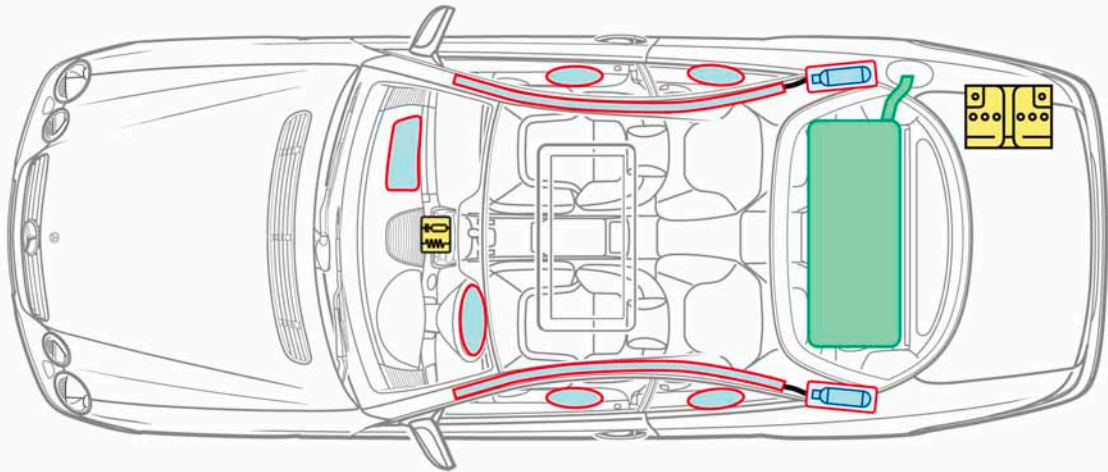

Legend



Airbag



Structural reinforcements

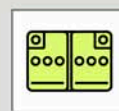

Battery



Gas generator



Rollover protection



High-voltage components



Seat belt tensioner



Fuel tank



Cutting points



Gas filled spring device



Control unit

**CL-Class
Coupé
Model 216**

ab 2006

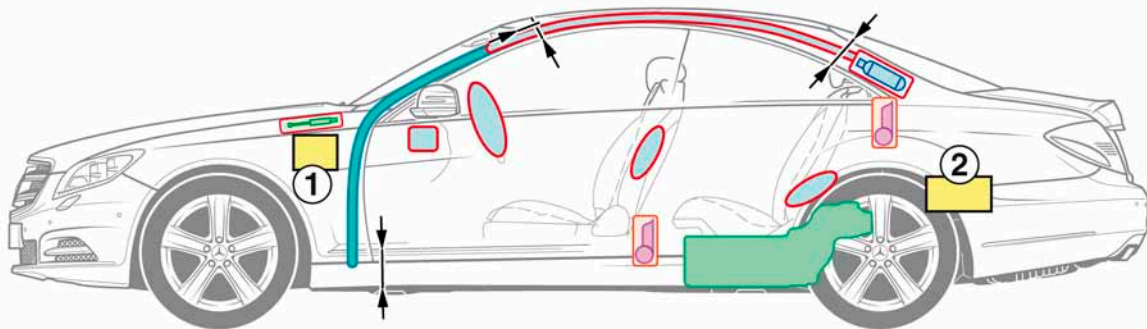
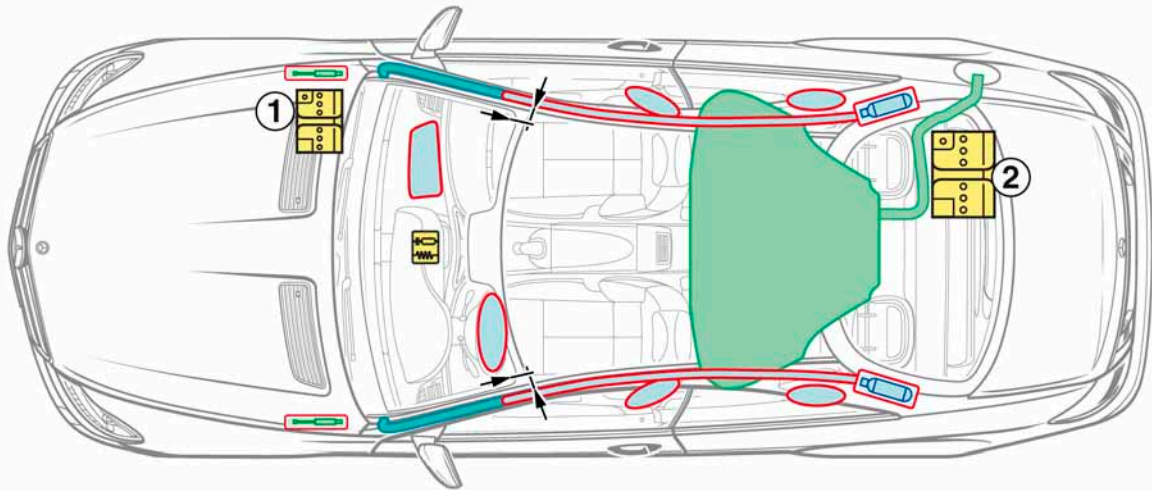

- 1 Starter battery (engine compartment)
- 2 Power supply battery (trunk)

Legend



Airbag



Structural reinforcements

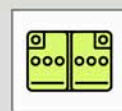

Battery



Gas generator



Rollover protection



High-voltage components



Seat belt tensioner



Fuel tank



Cutting points



Gas filled spring device



Control unit

**CLS-Class
Coupé
Model 219**

2004-2009

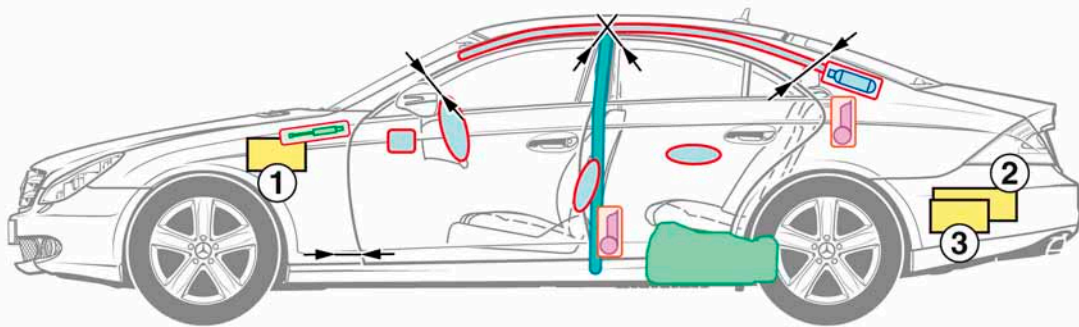
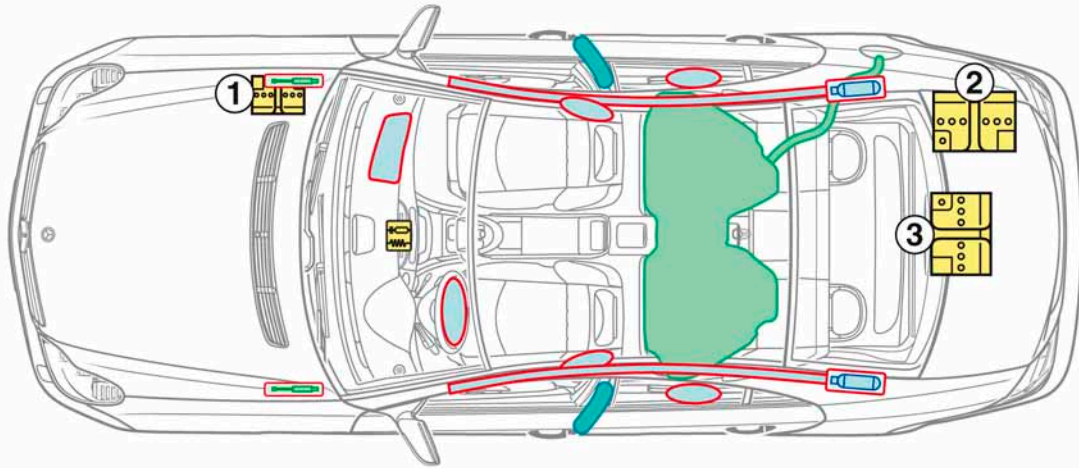

- 1 Additional battery (engine compartment)
- 2 Main battery (equipment with spare wheel)
- 3 Main battery (equipment without spare wheel)

Legend



Airbag



Structural reinforcements

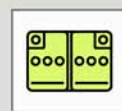

Battery

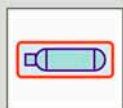

Gas generator



Rollover protection



High-voltage components



Seat belt tensioner



Fuel tank



Cutting points



Gas filled spring device



Control unit





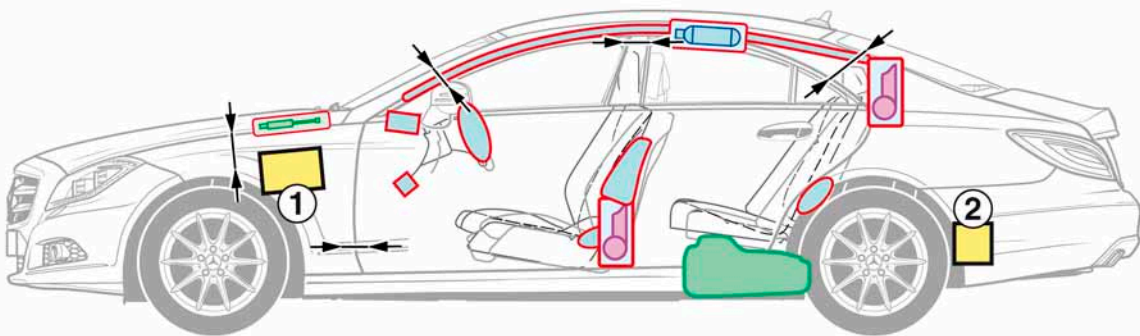
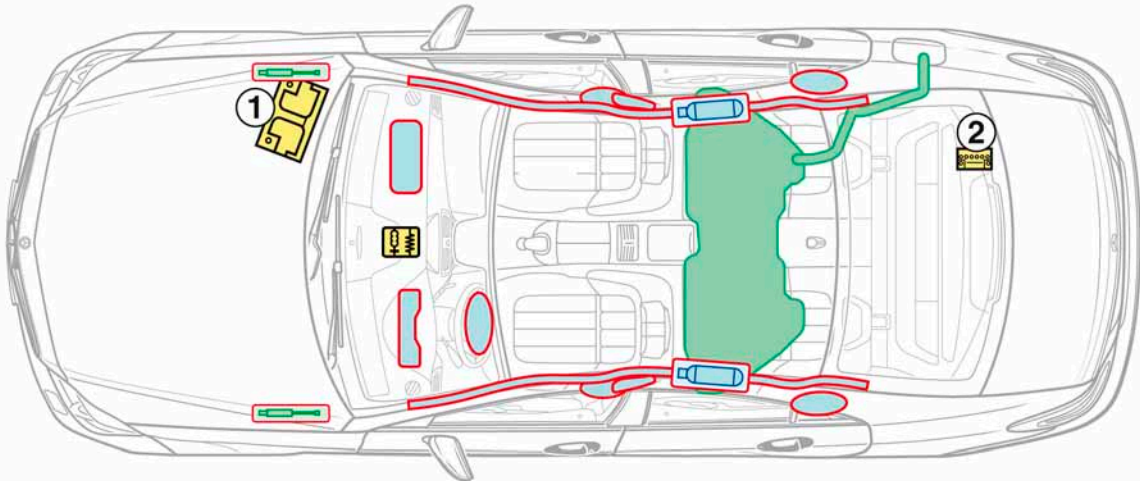



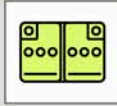

CLS-Class
Coupe
Model 218

as of 2010

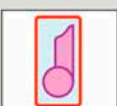

- 1 Power supply battery
- 2 Additional battery ECO Start-Stopp

Legend

	Airbag		Structural reinforcements		Battery
	Gas generator		Rollover protection		High-voltage components
	Seat belt tensioner		Fuel tank		Cutting points
	Gas filled spring device		Control unit		





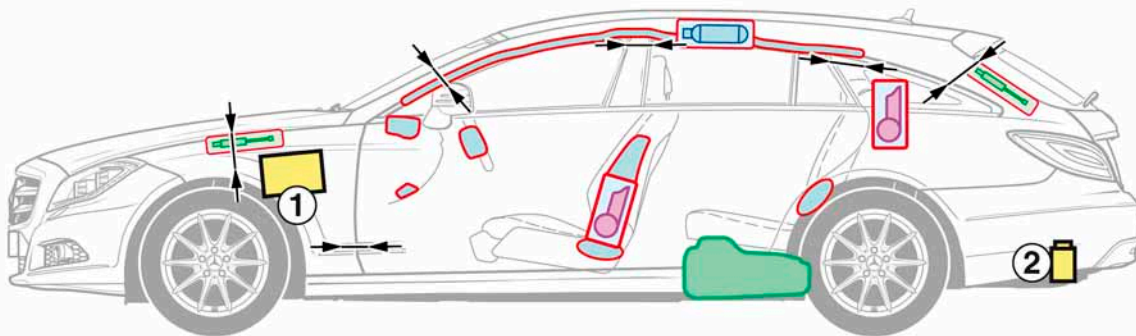
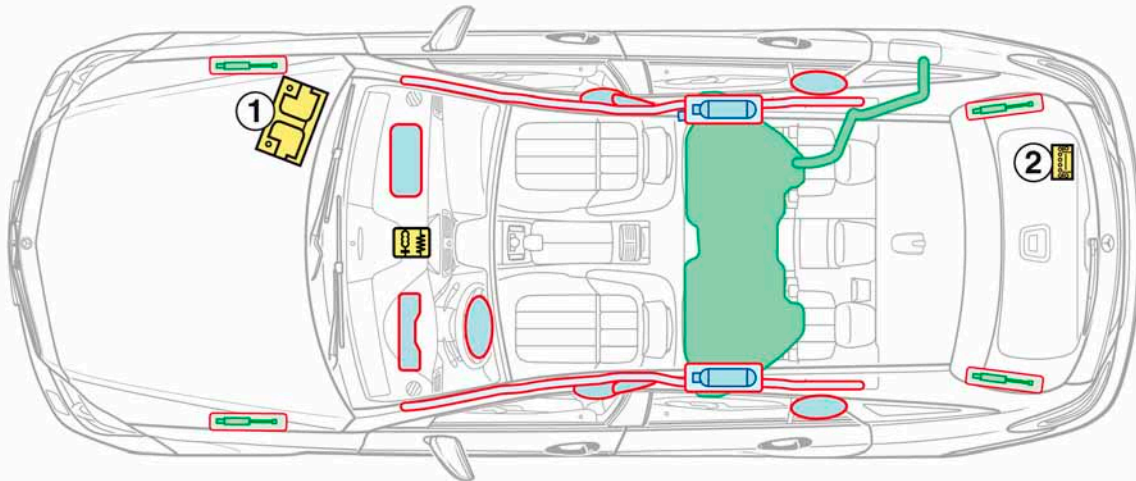



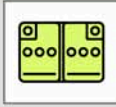

**CLS-Class
Shooting
Break
Model 218**

as of 2012



- 1 Power supply battery
- 2 Additional battery ECO Start-Stopp

Legend

	Airbag		Structural reinforcements		Battery
	Gas generator		Rollover protection		High-voltage components
	Seat belt tensioner		Fuel tank		Cutting points
	Gas filled spring device		Control unit		

**E-Class
Coupé
Model 123**

1977-1985

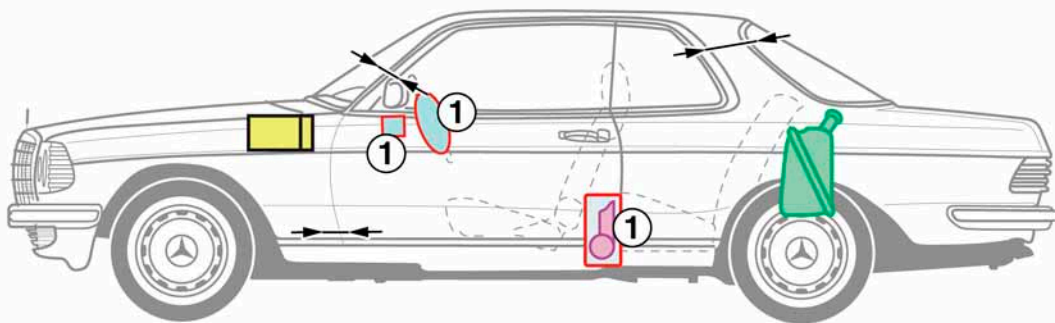
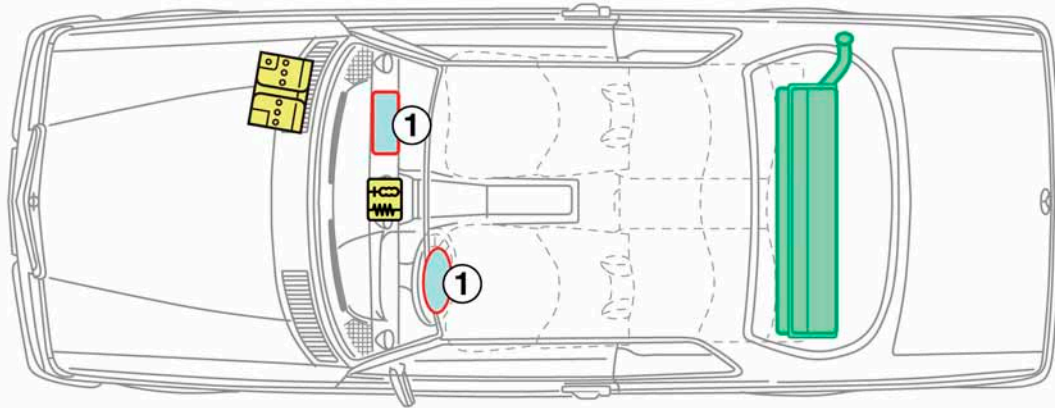

1 as of 1980

Legend



Airbag

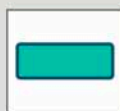

Structural reinforcements

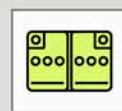

Battery



Gas generator



Rollover protection



High-voltage components



Seat belt tensioner



Fuel tank



Cutting points



Gas filled spring device



Control unit

**E-Class
Coupé
Model 124**

1987-1997

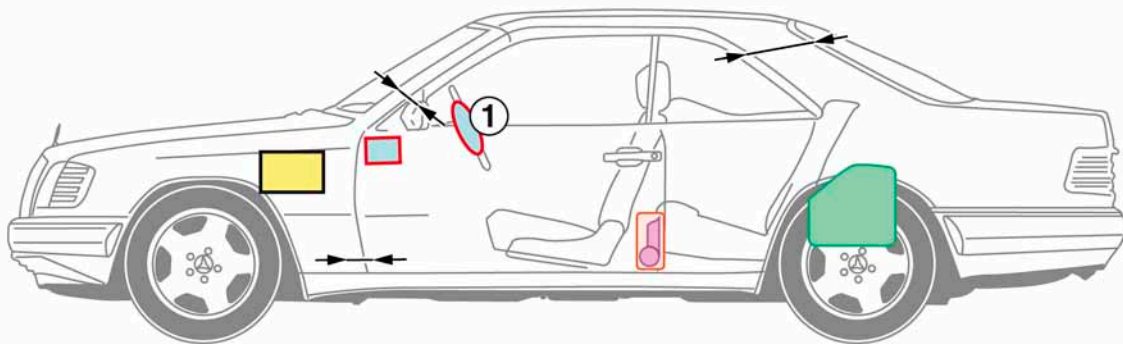
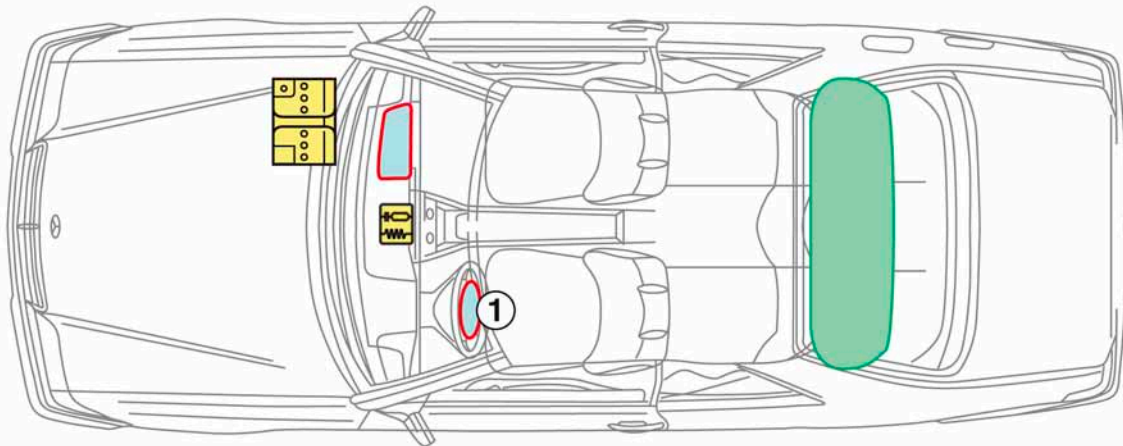

1 Standard as of 1992

Legend



Airbag



Structural reinforcements

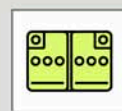

Battery

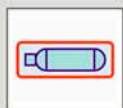

Gas generator



Rollover protection



High-voltage components



Seat belt tensioner



Fuel tank



Cutting points



Gas filled spring device



Control unit

**E-Class
Coupé
Model 207**

as of 2009

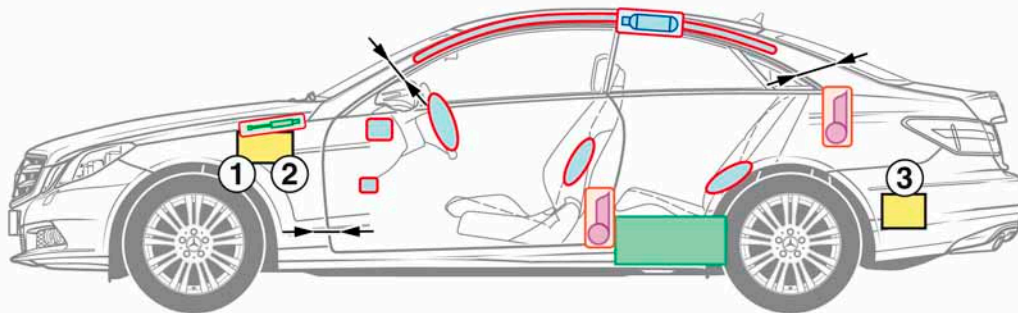
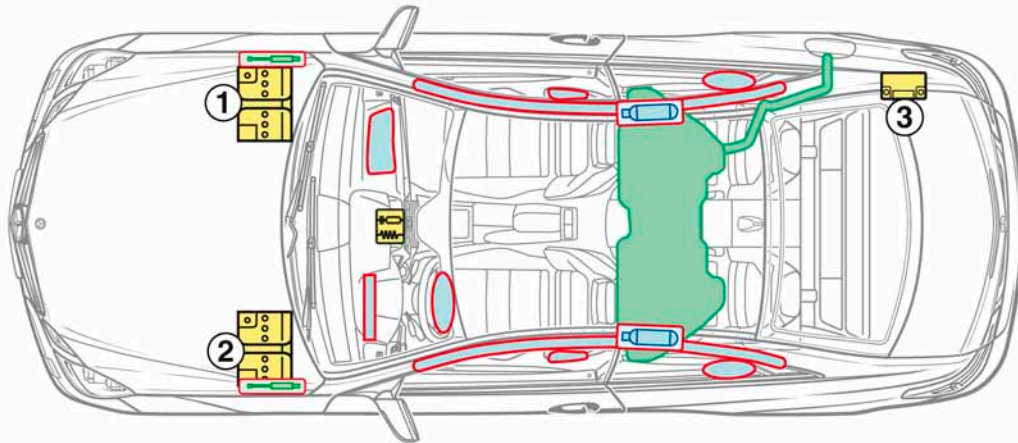

- 1 Power supply battery, LHD
- 2 Power supply battery, RHD
- 3 Additional battery ECO Start-Stop

Legend



Airbag



Structural reinforcements

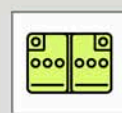

Battery

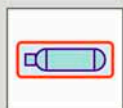

Gas generator



Rollover protection



High-voltage components



Seat belt tensioner



Fuel tank



Cutting points



Gas filled spring device



Control unit

**SLC-Class
Coupé
Model 107**

1971-1989

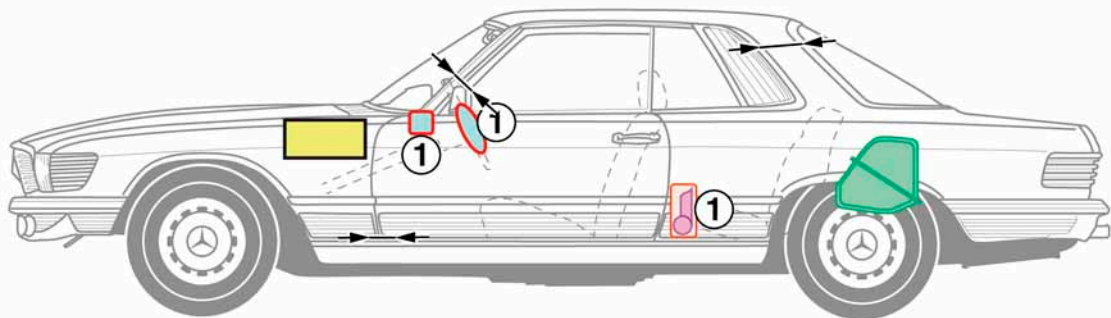
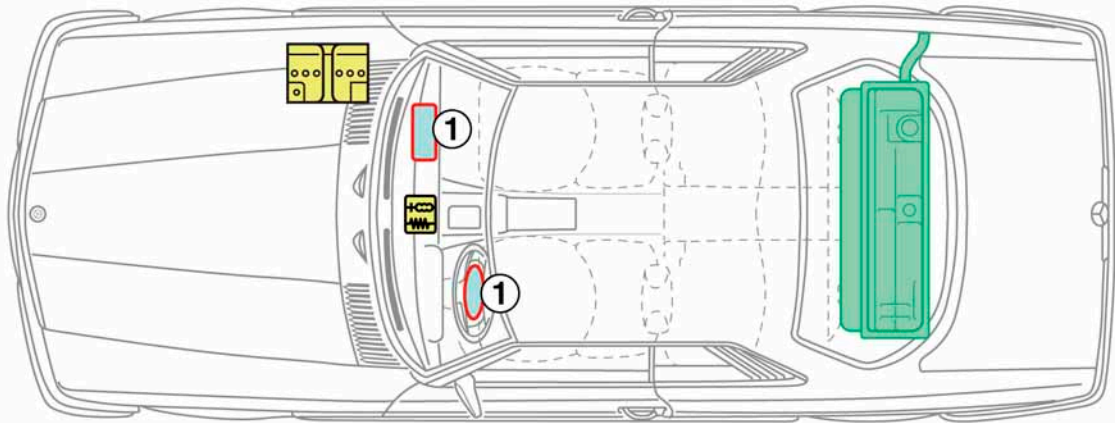

1 as of 1982

Legend



Airbag

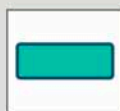

Structural reinforcements

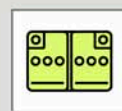

Battery



Gas generator



Rollover protection



High-voltage components



Seat belt tensioner



Fuel tank



Cutting points

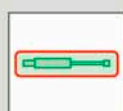

Gas filled spring device



Control unit

**S-Class
Coupé
Model 126**

1981-1991

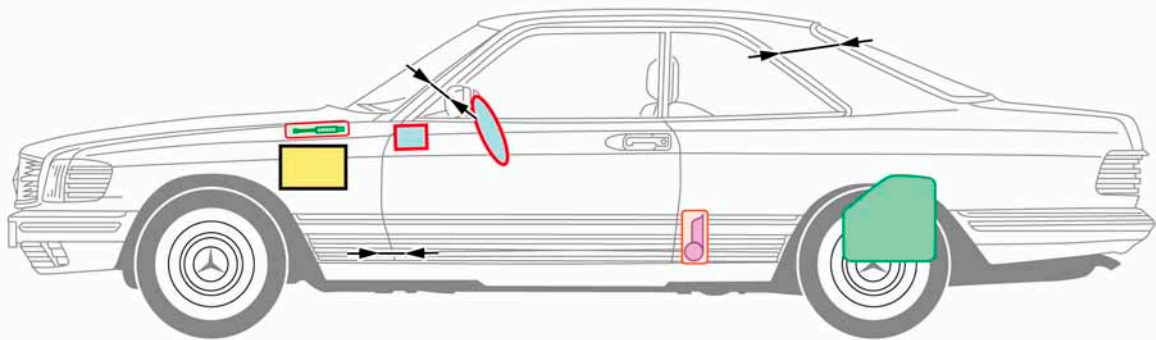
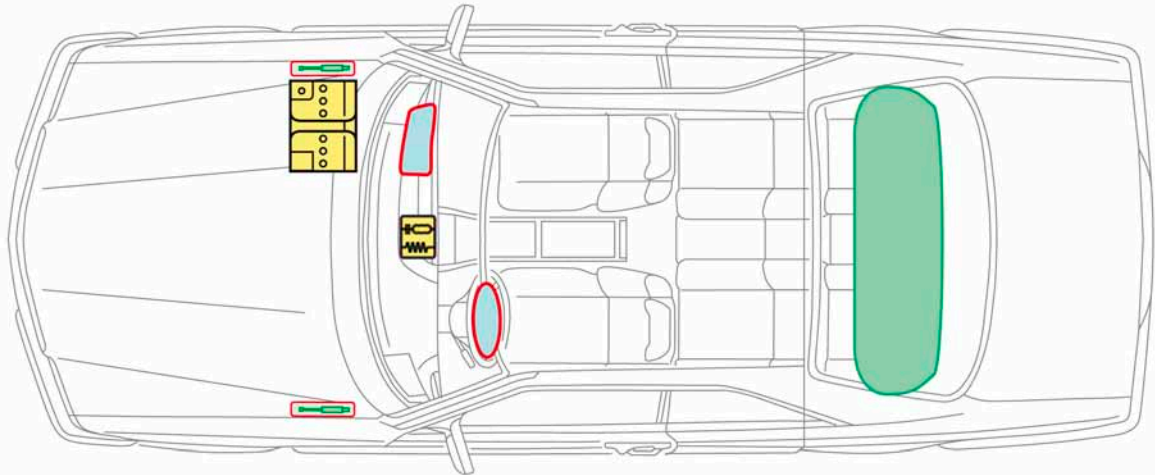

Legend



Airbag



Structural reinforcements

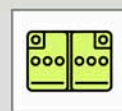

Battery

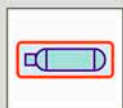

Gas generator



Rollover protection



High-voltage components



Seat belt tensioner



Fuel tank



Cutting points



Gas filled spring device



Control unit





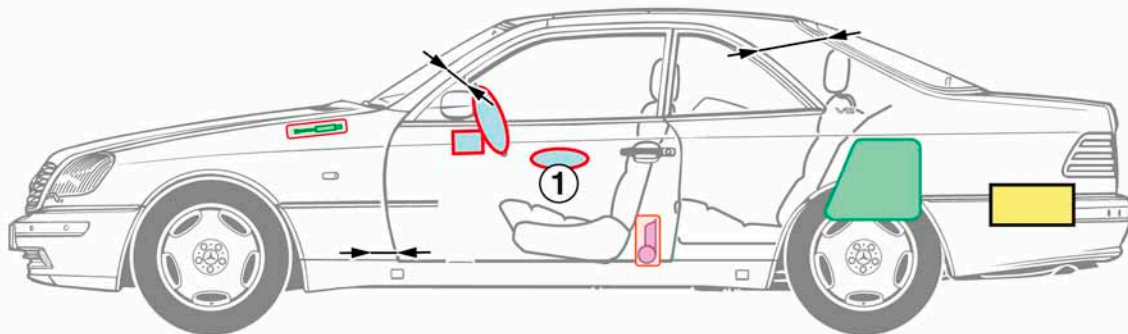
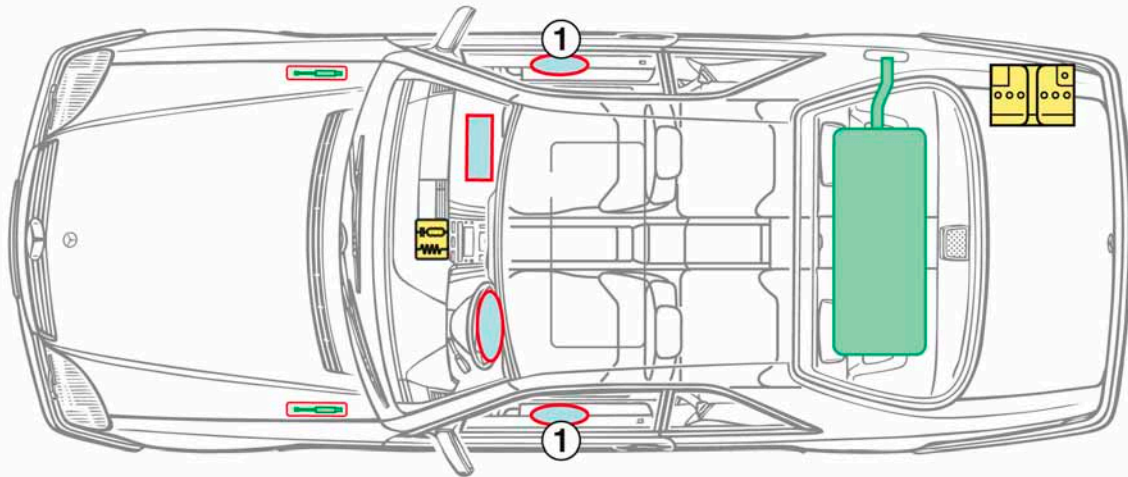



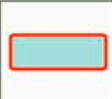

**S-Class
Coupé
Model 140**

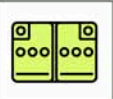
1992-1998



1 Special equipment

Legend

	Airbag		Structural reinforcements		Battery
	Gas generator		Rollover protection		High-voltage components
	Seat belt tensioner		Fuel tank		Cutting points
	Gas filled spring device		Control unit		

**CLK-Class
Cabriolet
Model 208**

1997-2002

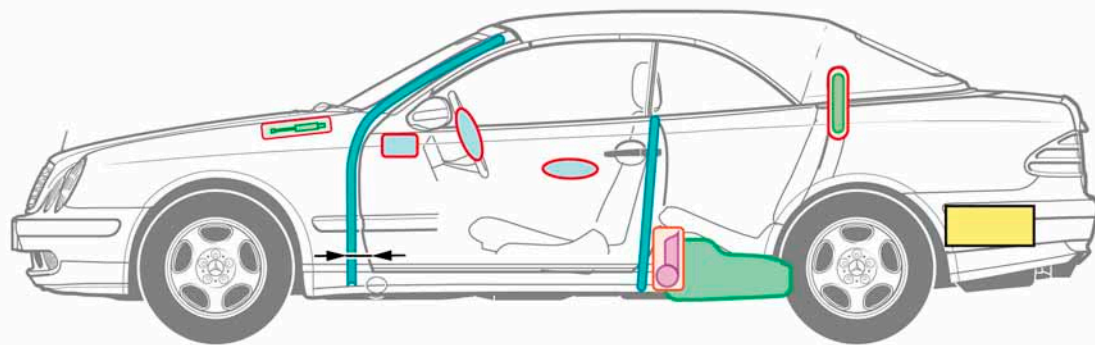
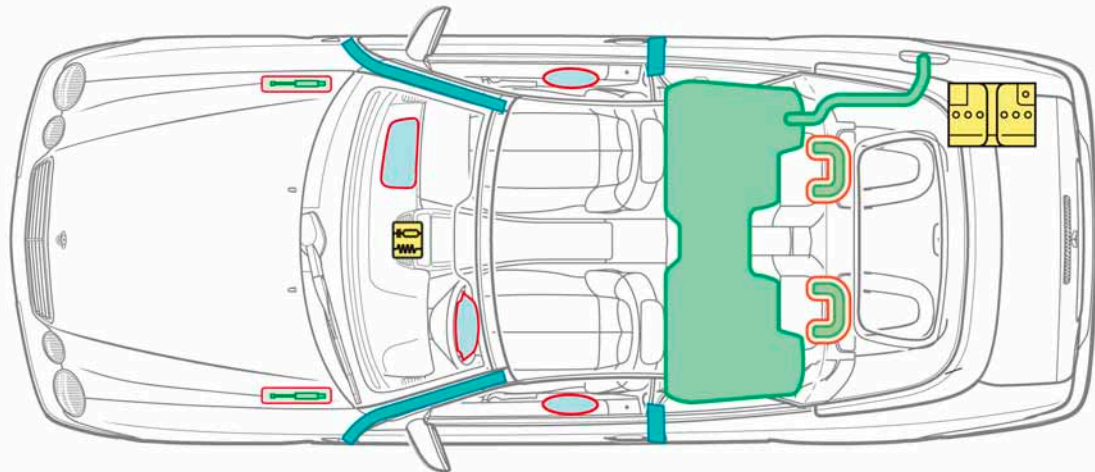

Legend



Airbag



Structural reinforcements

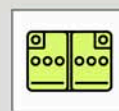

Battery



Gas generator



Rollover protection



High-voltage components



Seat belt tensioner



Fuel tank



Cutting points

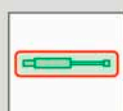

Gas filled spring device



Control unit

**CLK-Class
Cabriolet
Model 209**

2003-2009

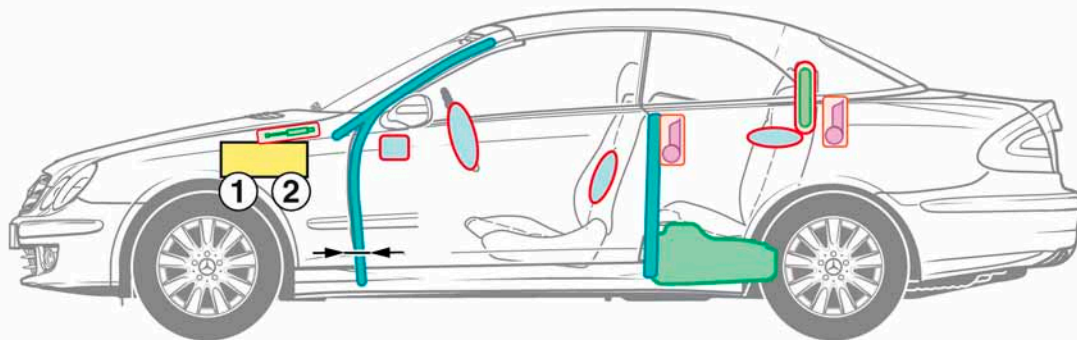
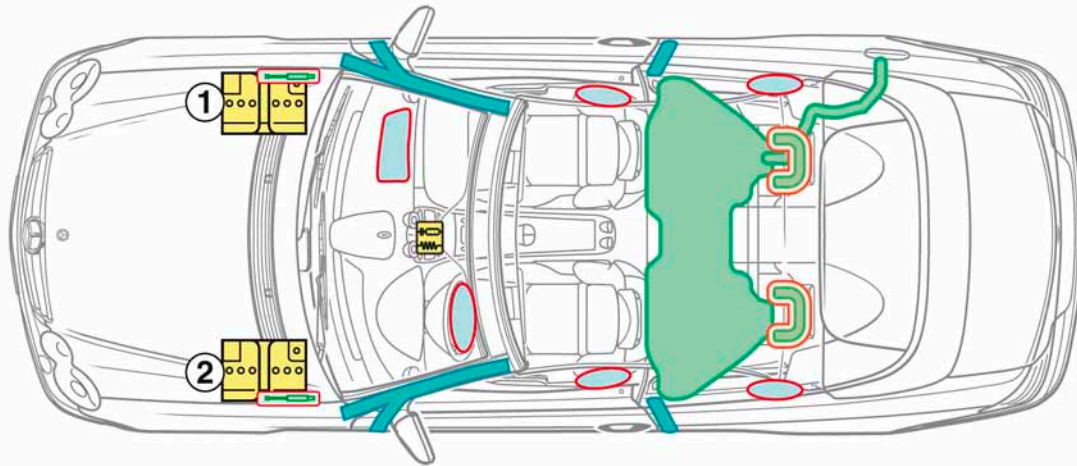

1 LHD vehicle
2 RHD vehicle

Legend

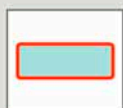

Airbag



Structural reinforcements

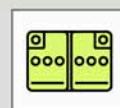

Battery



Gas generator



Rollover protection



High-voltage components



Seat belt tensioner



Fuel tank



Cutting points



Gas filled spring device



Control unit

**E-Class
Cabriolet
Model 124**

1987-1997

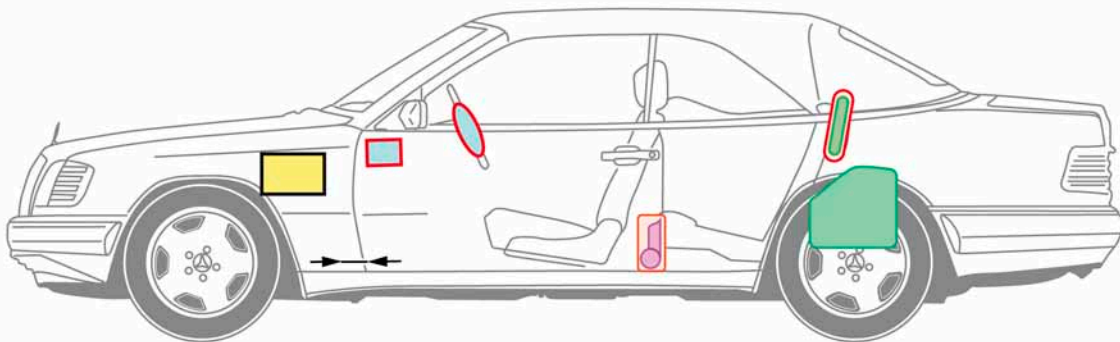
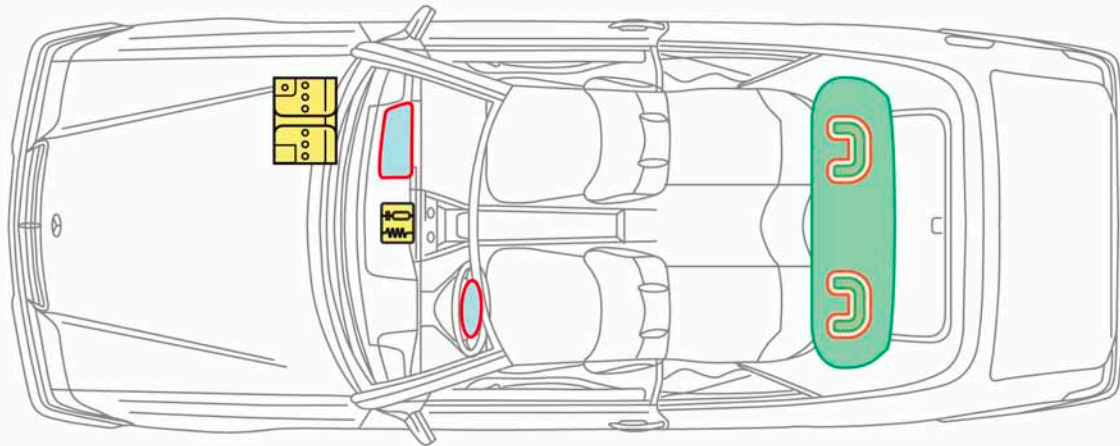

Legend



Airbag



Structural reinforcements

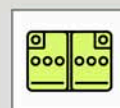

Battery



Gas generator



Rollover protection



High-voltage components



Seat belt tensioner



Fuel tank



Cutting points



Gas filled spring device



Control unit

**E-Class
Cabriolet
Model 207**

as of 2010

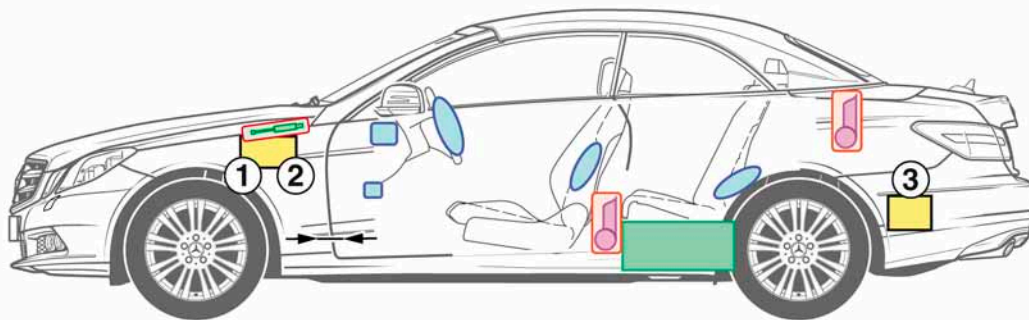
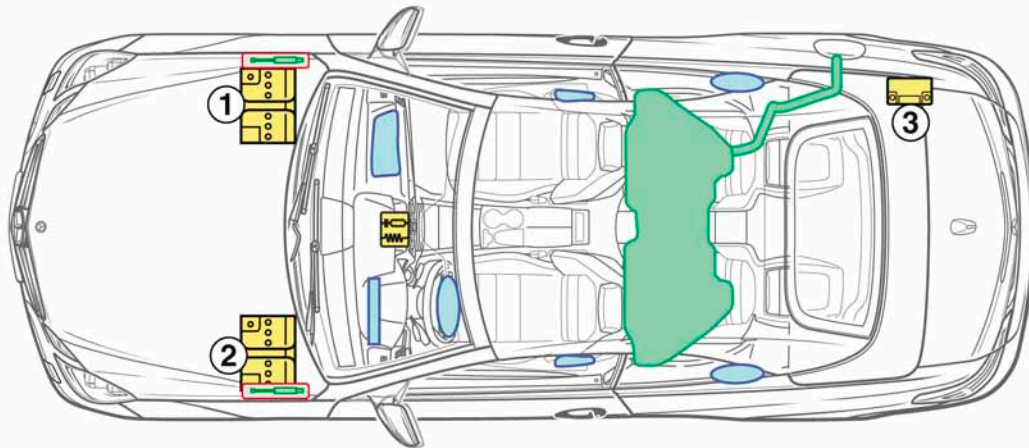

1 Battery in engine compartment
(with 4- and 6-cylinder engine, LHD)

2 Battery in engine compartment
(with 4- and 6-cylinder engine, RHD)

3 Battery in trunk (with 8-cylinder engine)

Legend



Airbag



Structural reinforcements

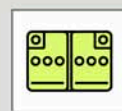

Battery

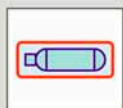

Gas generator



Rollover protection



High-voltage components



Seat belt tensioner



Fuel tank



Cutting points



Gas filled spring device



Control unit

**SLK-Class
Roadster
Model 170**

1996-2004

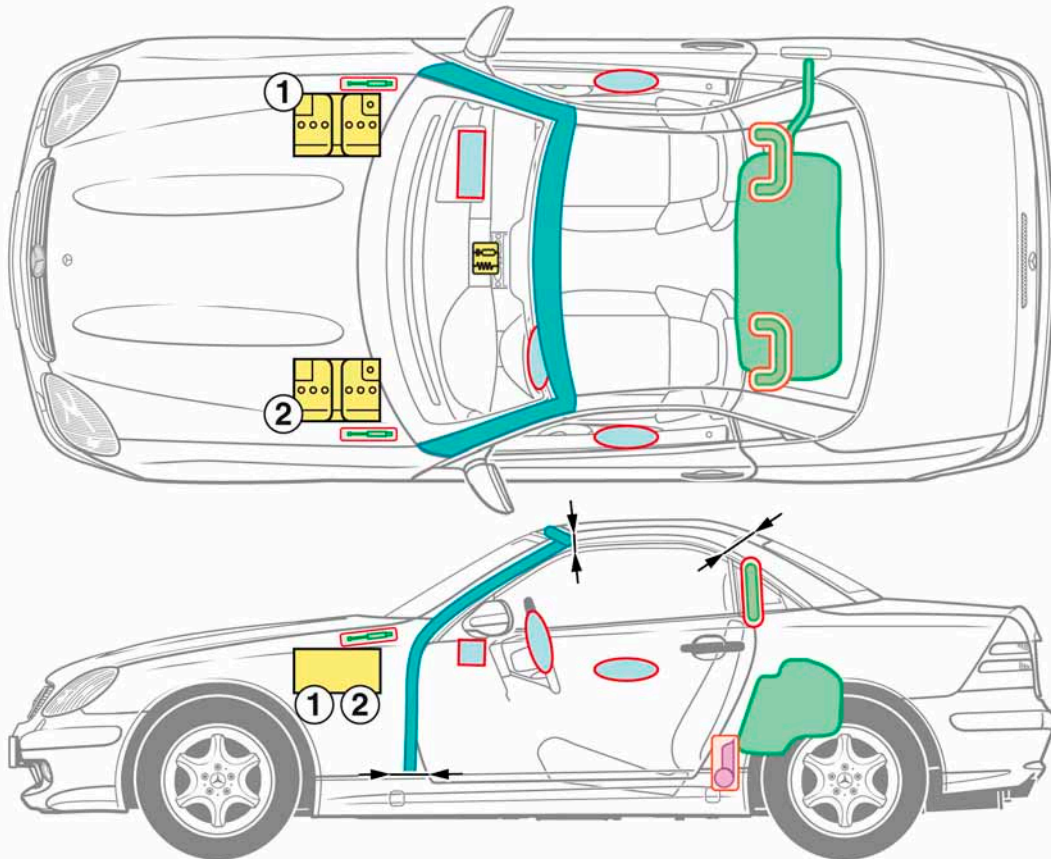

1 LHD vehicle
2 RHD vehicle

Legend



Airbag



Structural reinforcements

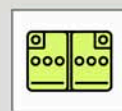

Battery



Gas generator



Rollover protection



High-voltage components



Seat belt tensioner



Fuel tank



Cutting points



Gas filled spring device



Control unit

**SLK-Class
Roadster
Model 171**

as of 2004

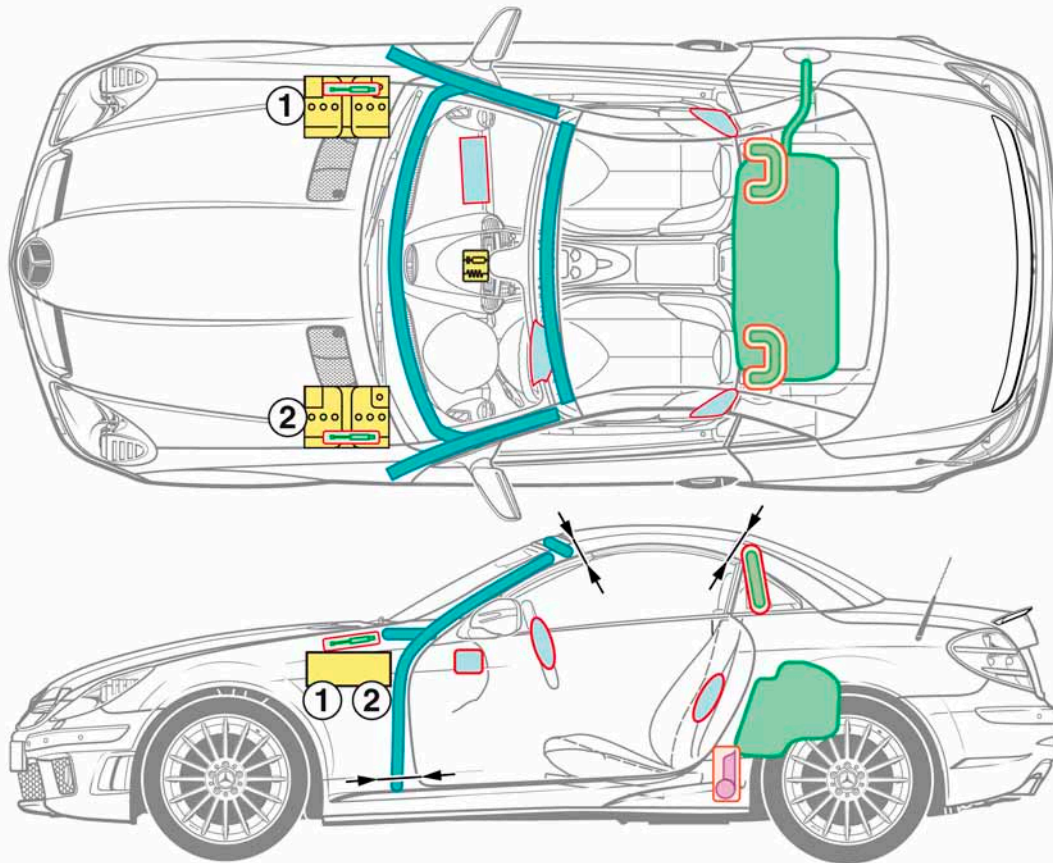

- 1 LHD vehicle
- 2 RHD vehicle

Legend



Airbag



Structural reinforcements

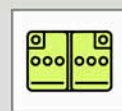

Battery

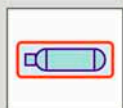

Gas generator



Rollover protection



High-voltage components

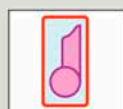

Seat belt tensioner



Fuel tank



Cutting points



Gas filled spring device



Control unit





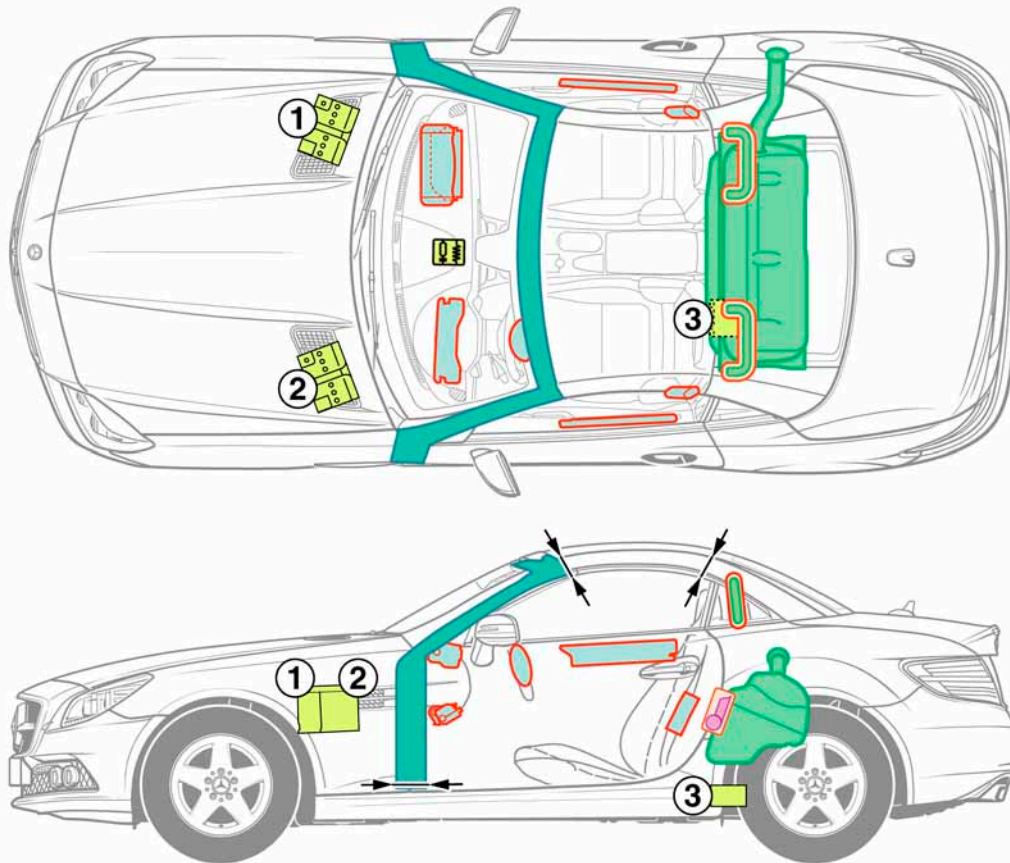



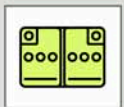

**SLK-Class
Roadster
Model 172**

as of 2011



- 1 Power supply battery, LHD
- 2 Power supply battery, RHD
- 3 Additional battery ECO Start-Stopp

Legend

	Airbag		Structural reinforcements		Battery
	Gas generator		Rollover protection		High-voltage components
	Seat belt tensioner		Fuel tank		Cutting points
	Gas filled spring device		Control unit		

**SL-Class
Roadster
Model 107**

1971-1989

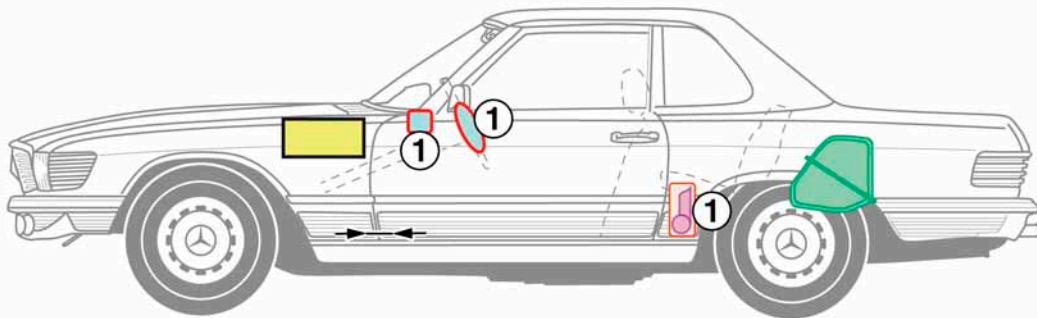
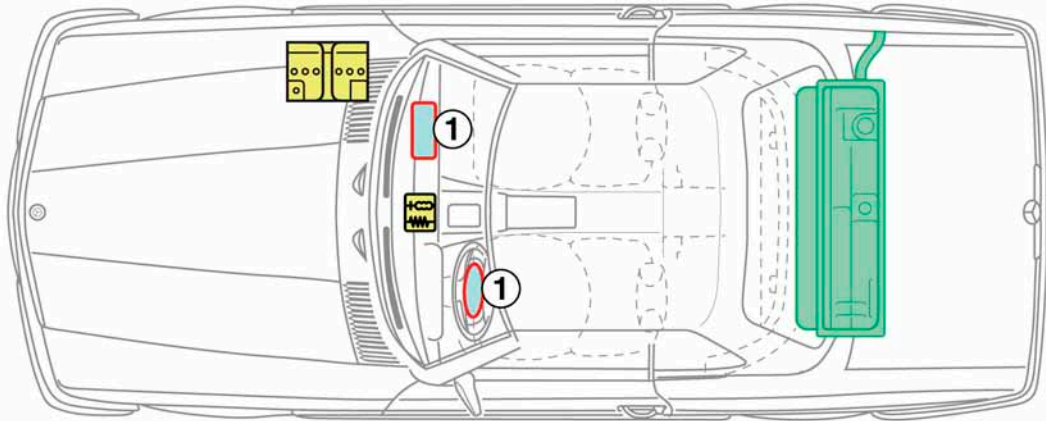

1 as of 1982

Legend



Airbag

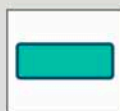

Structural reinforcements

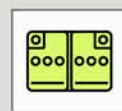

Battery

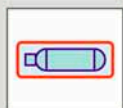

Gas generator



Rollover protection



High-voltage components



Seat belt tensioner



Fuel tank



Cutting points



Gas filled spring device



Control unit

**SL-Class
Roadster
Model 129**

1989-2001

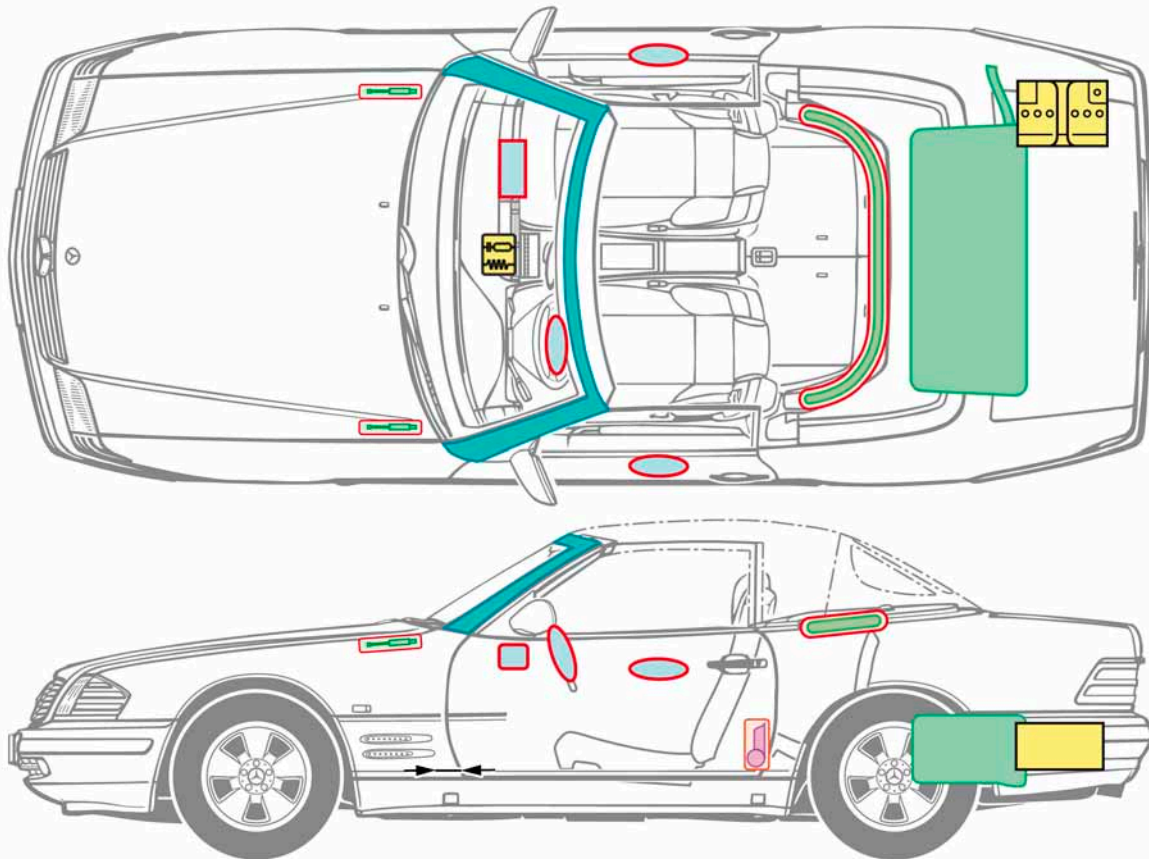

Legend



Airbag



Structural reinforcements

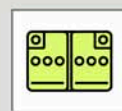

Battery



Gas generator



Rollover protection



High-voltage components



Seat belt tensioner



Fuel tank



Cutting points

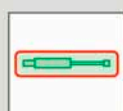

Gas filled spring device



Control unit

**SL-Class
Roadster
Model 230**

as of 2001

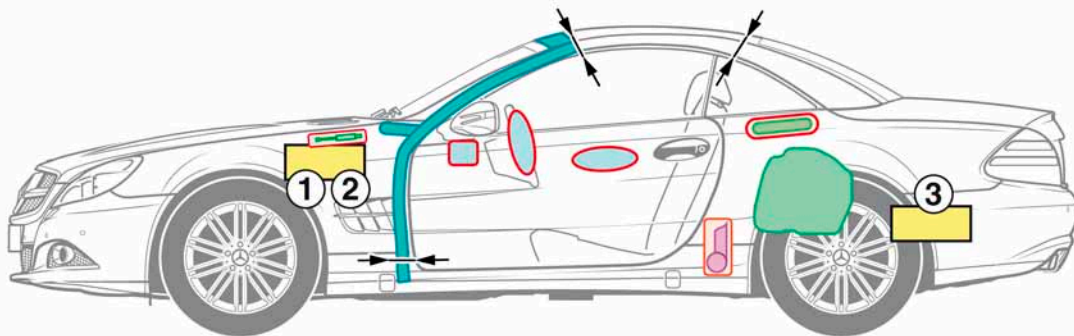
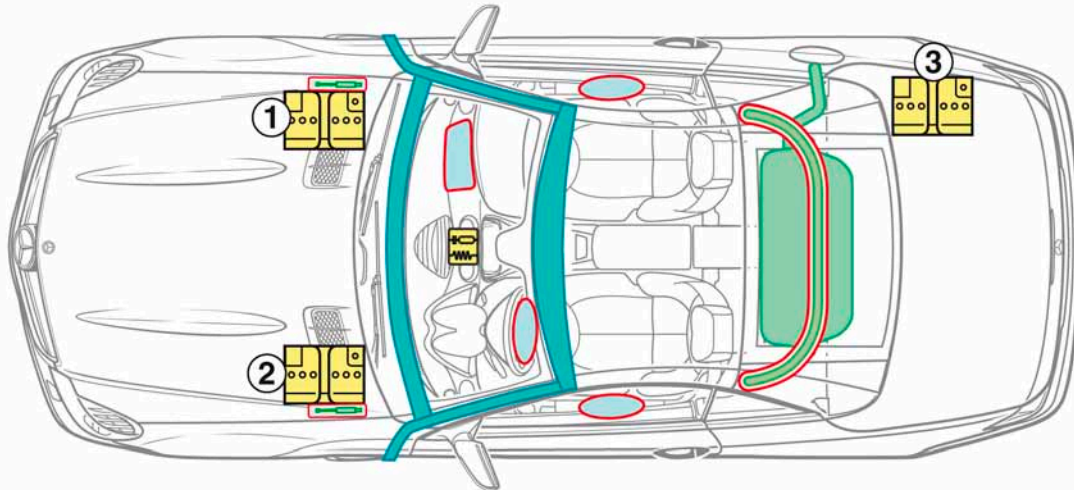

1 Starter battery, LHD
2 Starter battery, RHD

3 Power supply battery

Legend



Airbag



Structural reinforcements

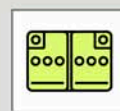

Battery

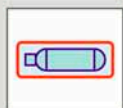

Gas generator



Rollover protection



High-voltage components



Seat belt tensioner



Fuel tank



Cutting points



Gas filled spring device



Control unit

**SL-Class
Roadster
Model 231**

as of 2012

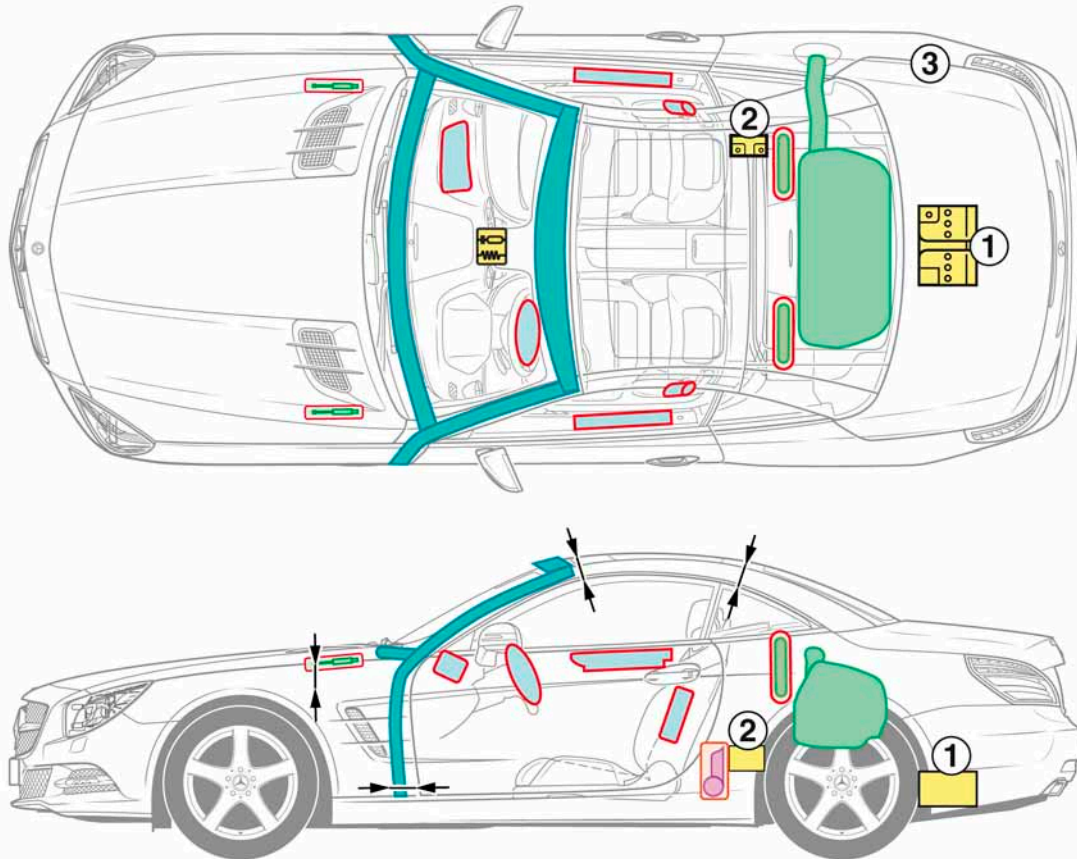

- 1 Power supply battery
- 2 Additional battery ECO Start-Stopp

Legend



Airbag



Structural reinforcements

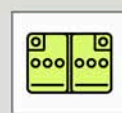

Battery



Gas generator



Rollover protection



High-voltage components



Seat belt tensioner



Fuel tank



Cutting points



Gas filled spring device



Control unit





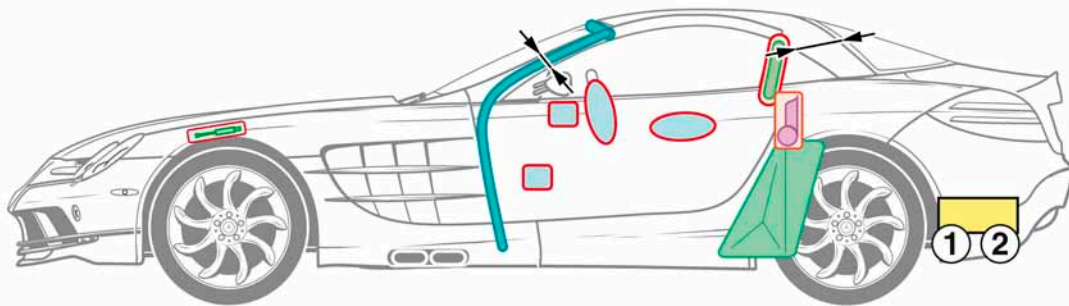
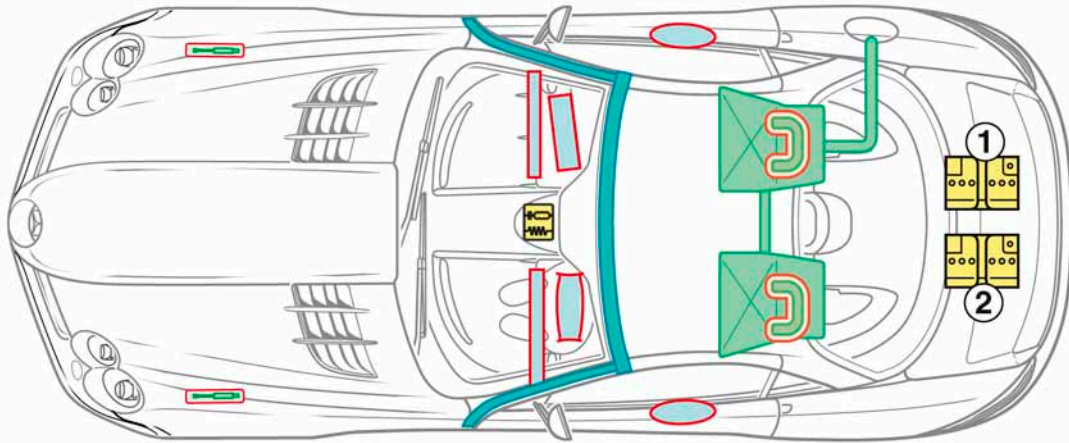



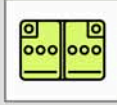
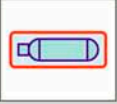

**SLR
McLaren
Model 199**

2004 2009



- 1 Starter battery
- 2 Power supply battery

Legend

	Airbag		Structural reinforcements		Battery
	Gas generator		Rollover protection		High-voltage components
	Seat belt tensioner		Fuel tank		Cutting points
	Gas filled spring device		Control unit		





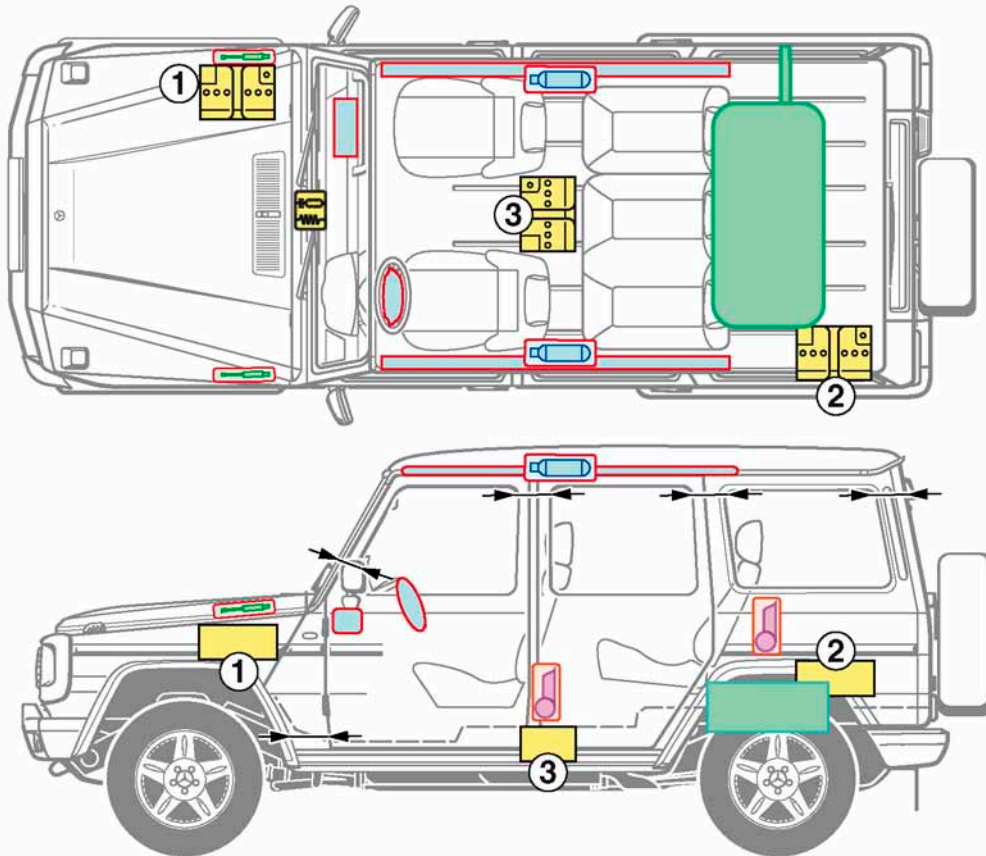



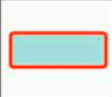

G-Class
Cross-country
vehicle
Model 463

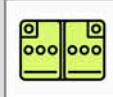
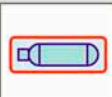
as of 1990



- 1 up to 09.1996
- 2 as of 10.1996 up to 11.2000
- 3 as of 12.2000

Legend

	Airbag		Structural reinforcements		Battery
	Gas generator		Rollover protection		High-voltage components
	Seat belt tensioner		Fuel tank		Cutting points
	Gas filled spring device		Control unit		





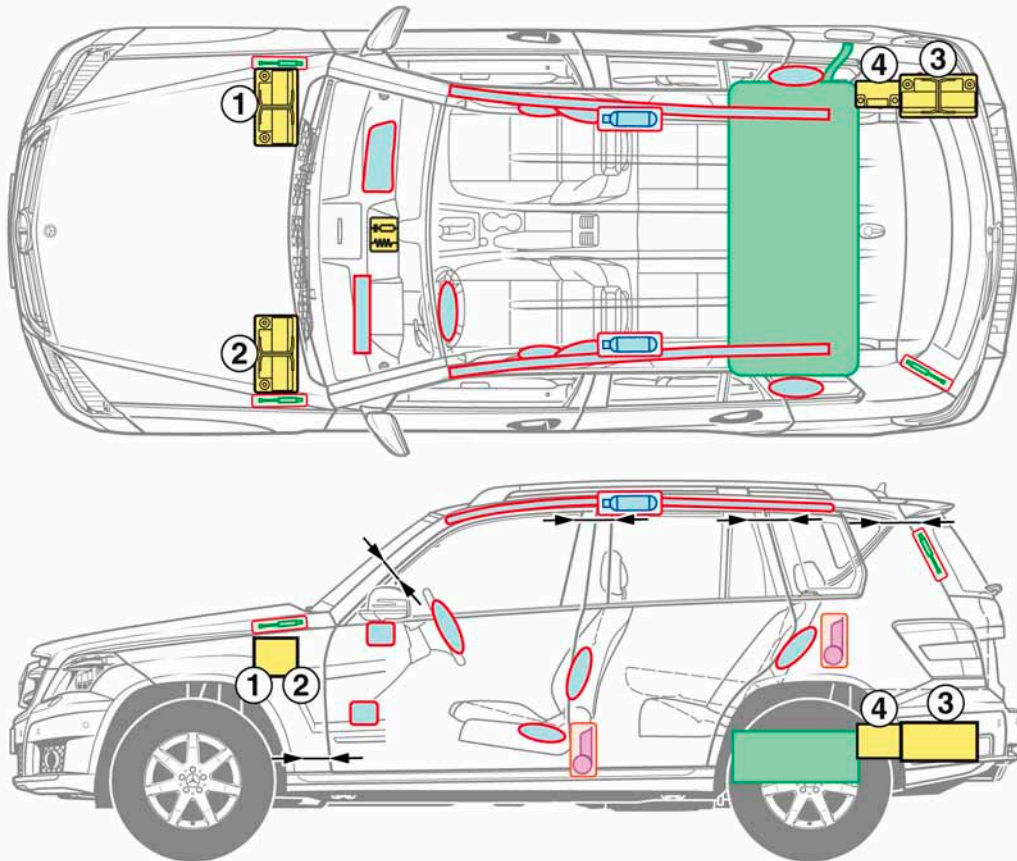

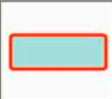

GLK-Class
Cross-country
vehicle
Model 204

as of 2008

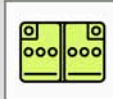

- 1 Power supply battery with gasoline engine, as of 1.12.2009 with 4- and 8-cylinder diesel engine, LHD
- 2 Power supply battery with gasoline engine, as of 1.12.2009 with 4- and 8-cylinder diesel engine, RHD
- 3 Power supply battery with 6-cylinder diesel engine, up to 30.11.2009 with 4- and 8-cylinder diesel engine
- 4 Additional battery ECO Start-Stopp

Legend

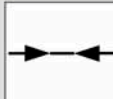
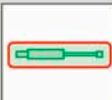
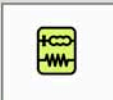
	Airbag		Structural reinforcements		Battery
	Gas generator		Rollover protection		High-voltage components
	Seat belt tensioner		Fuel tank		Cutting points
	Gas filled spring device		Control unit		

M-Class
Cross-country
vehicle
Model 163

1997-2005

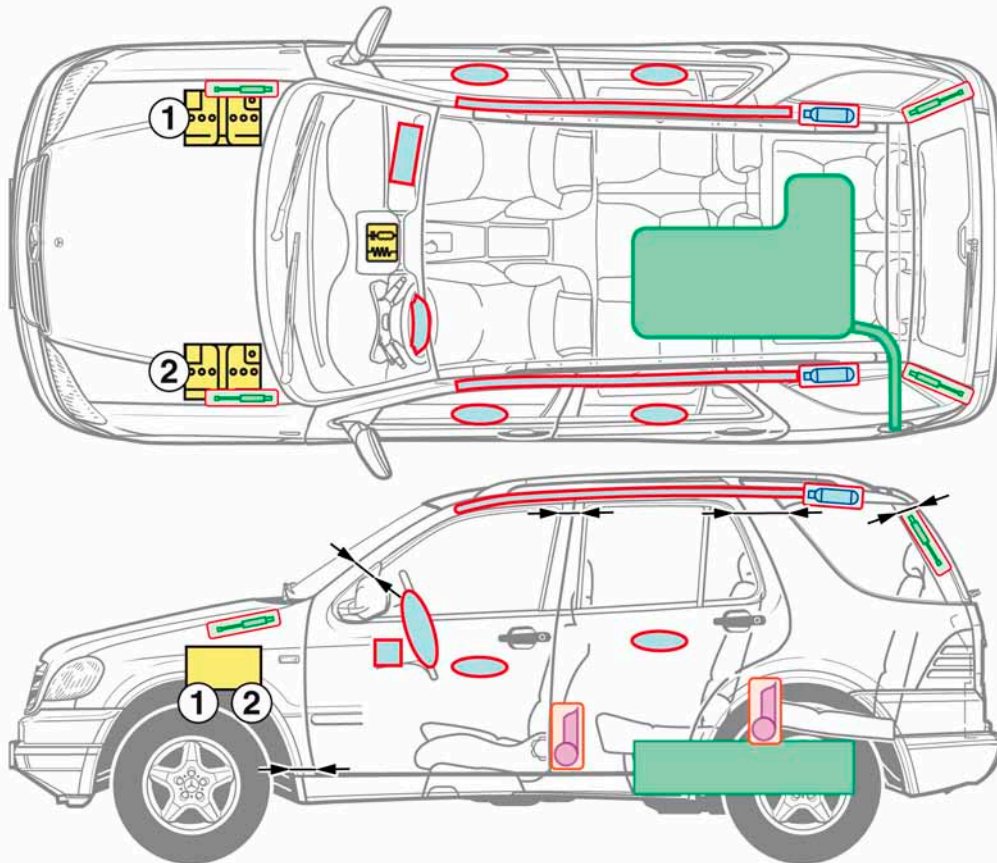

1 LHD vehicle
 2 RHD vehicle

Legend



Airbag



Structural reinforcements

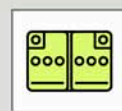

Battery



Gas generator



Rollover protection



High-voltage components



Seat belt tensioner



Fuel tank



Cutting points



Gas filled spring device



Control unit

M-Class
Cross-country
vehicle
Model 164

2005-2011

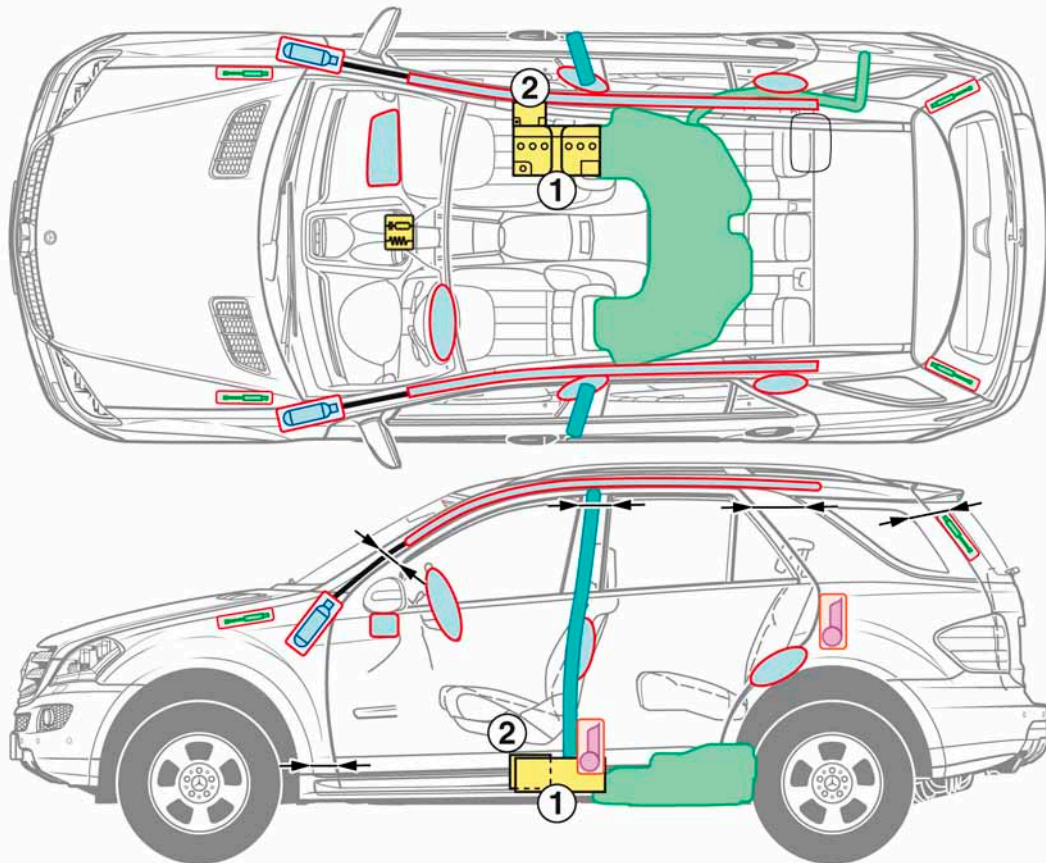

- 1 Main battery
- 2 Additional battery

Legend



Airbag



Structural reinforcements

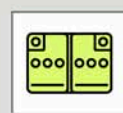

Battery



Gas generator



Rollover protection



High-voltage components



Seat belt tensioner



Fuel tank



Cutting points

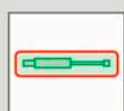

Gas filled spring device







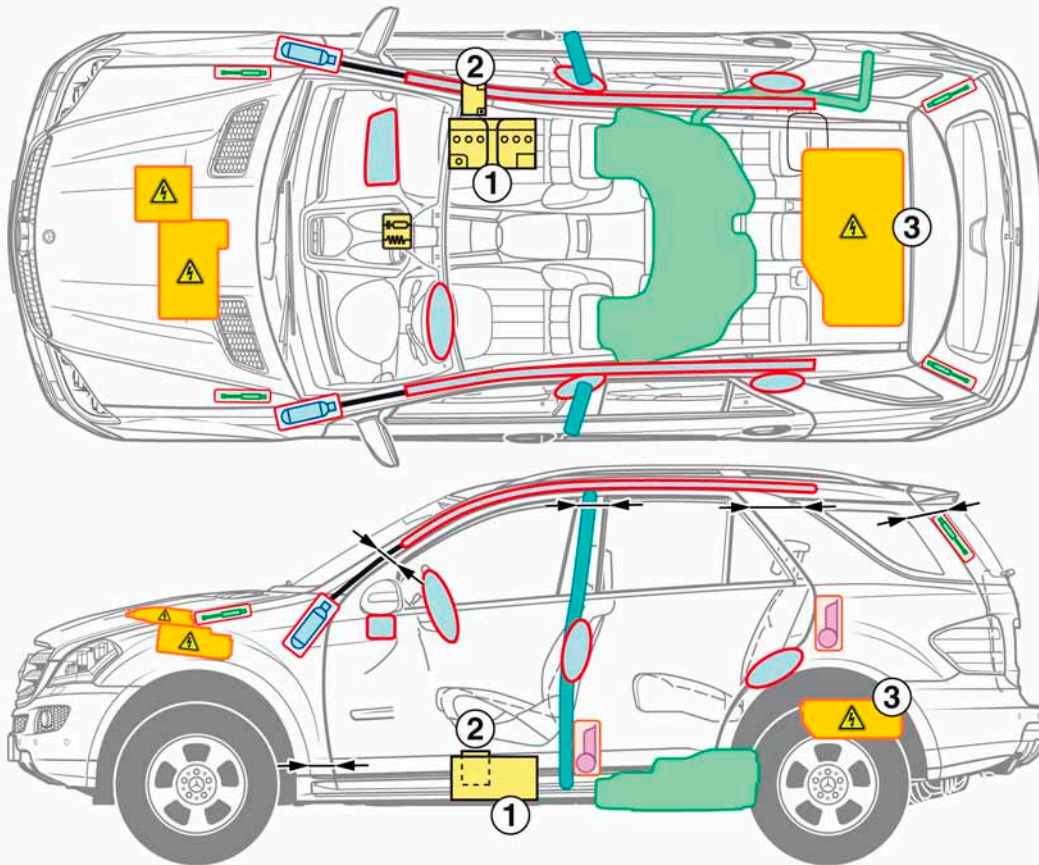



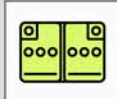

Control unit

**M-Class
HYBRID**
Cross-country
vehicle
Model 164
as of 2009

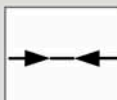

- 1 Main battery (12 V)
- 2 Additional battery (12 V)
- 3 High-voltage battery

Legend

	Airbag		Structural reinforcements		Battery
	Gas generator		Rollover protection		High-voltage components
	Seat belt tensioner		Fuel tank		Cutting points
	Gas filled spring device		Control unit		

M-Class
Cross-country
vehicle
Model 166

as of 2011

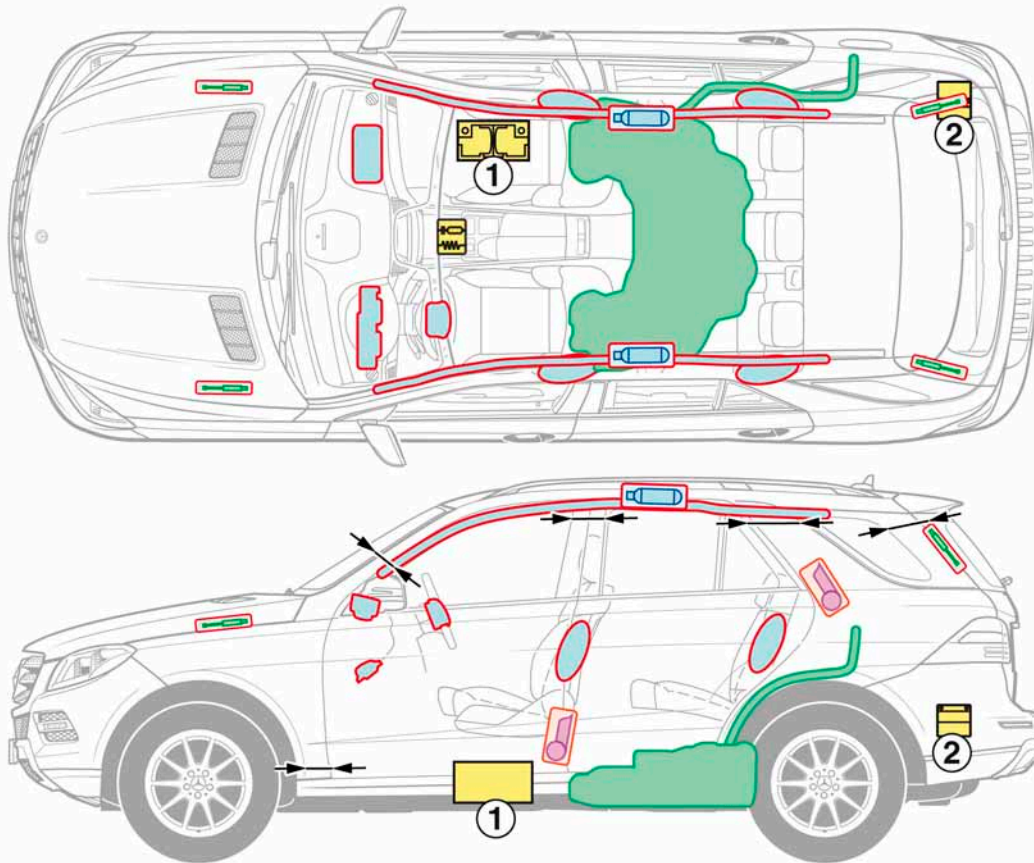

- 1 Main battery
- 2 Additional battery

Legend



Airbag



Structural reinforcements

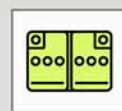

Battery



Gas generator



Rollover protection



High-voltage components



Seat belt tensioner



Fuel tank



Cutting points

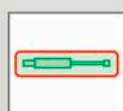

Gas filled spring device



Control unit

GL-Class
Cross-country
vehicle
Model 164

2006-2012

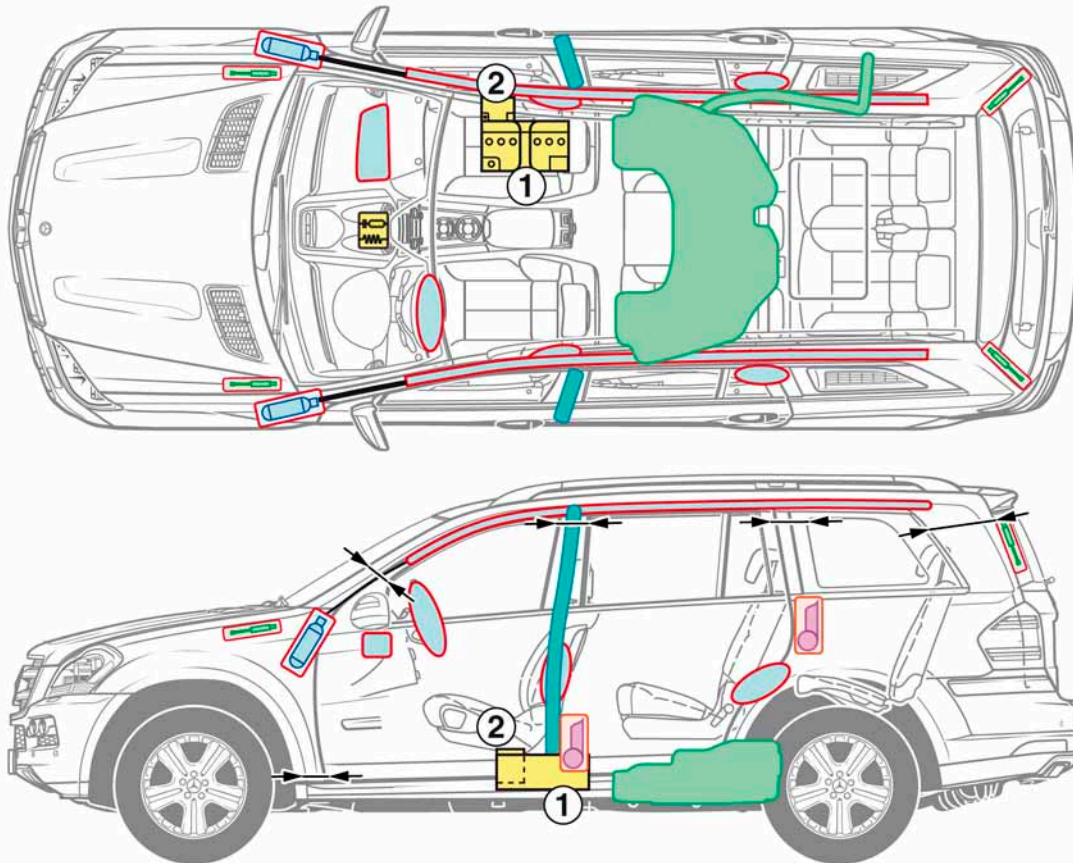

- 1 Main battery
- 2 Additional battery

Legend



Airbag



Structural reinforcements

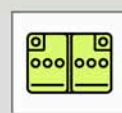

Battery



Gas generator



Rollover protection



High-voltage components



Seat belt tensioner



Fuel tank



Cutting points

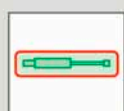

Gas filled spring device



Control unit





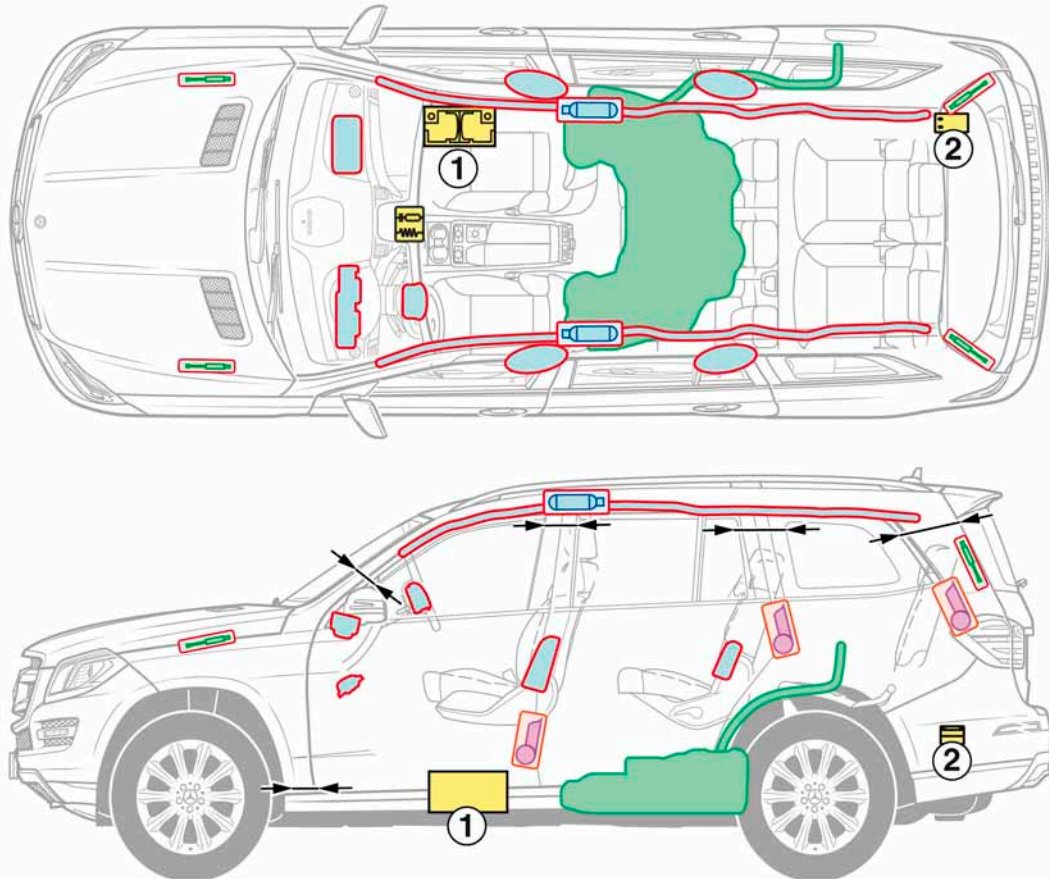



GL-Class
Cross-country
vehicle
Model 166

as of 2012

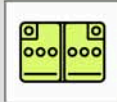
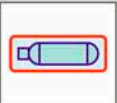

- 1 Main battery
- 2 Additional battery

Legend

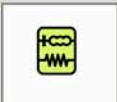
	Airbag		Structural reinforcements		Battery
	Gas generator		Rollover protection		High-voltage components
	Seat belt tensioner		Fuel tank		Cutting points
	Gas filled spring device		Control unit		

R-Class
Van
Model 251

as of 2005

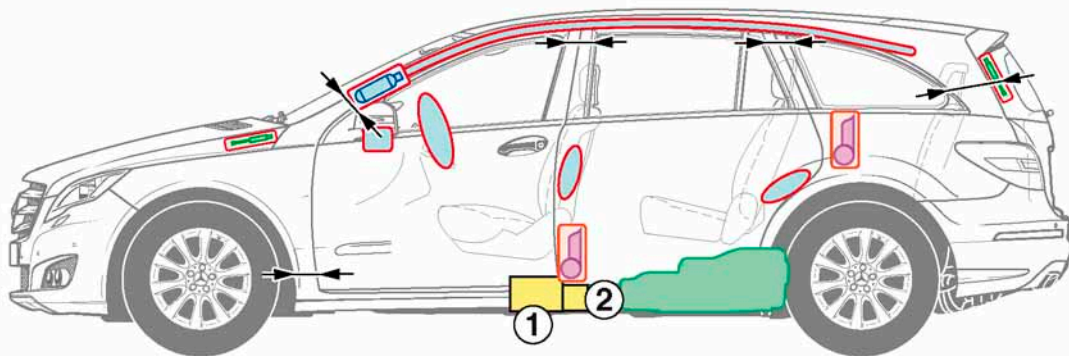
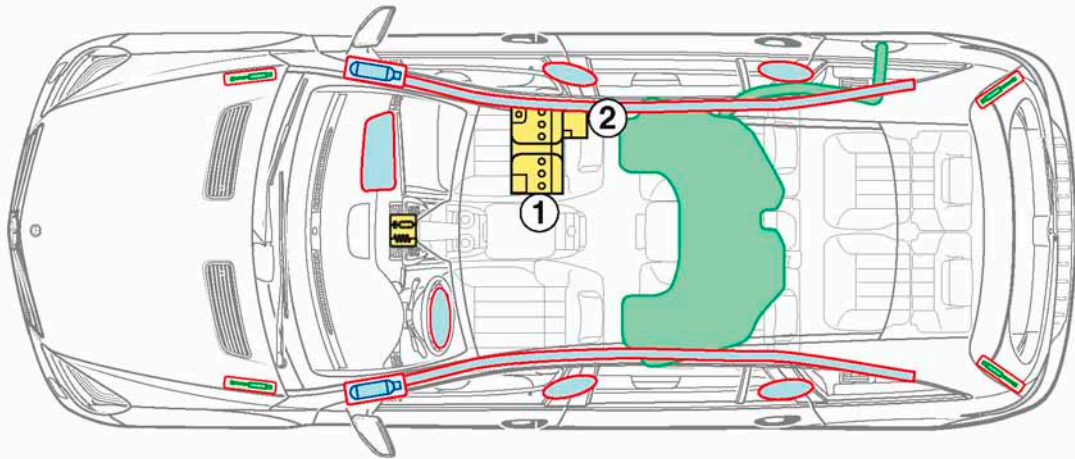

- 1 Main battery
- 2 Additional battery

Legend



Airbag



Structural reinforcements

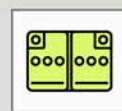

Battery



Gas generator



Rollover protection



High-voltage components



Seat belt tensioner



Fuel tank



Cutting points



Gas filled spring device



Control unit

**Vaneo
Model 4 14**

2002-2005

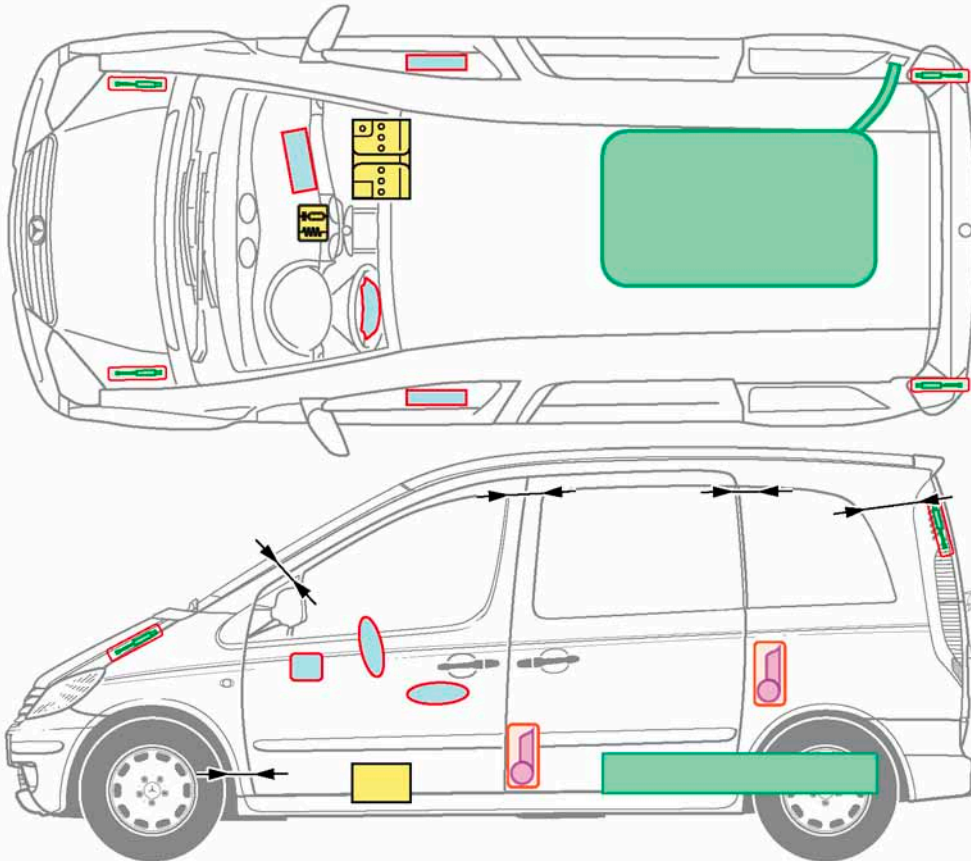

Legend



Airbag



Structural reinforcements

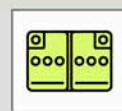

Battery



Gas generator



Rollover protection



High-voltage components



Seat belt tensioner



Fuel tank



Cutting points



Gas filled spring device



Control unit

**Citan
Van
Model 415**

as of 2012

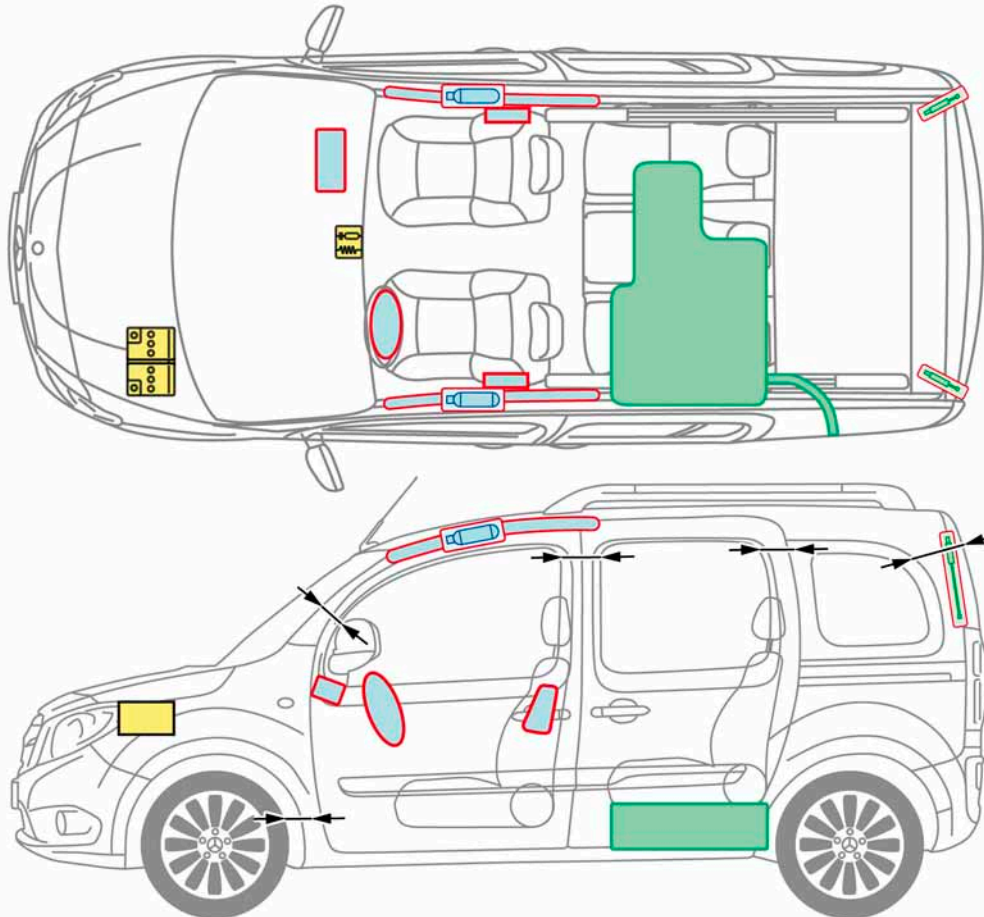

Legend



Airbag

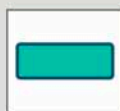

Structural reinforcements

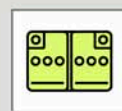

Battery



Gas generator



Rollover protection



High-voltage components



Seat belt tensioner



Fuel tank



Cutting points



Gas filled spring device



Control unit

**V-Class
Vito
Model 638**

1996-2003

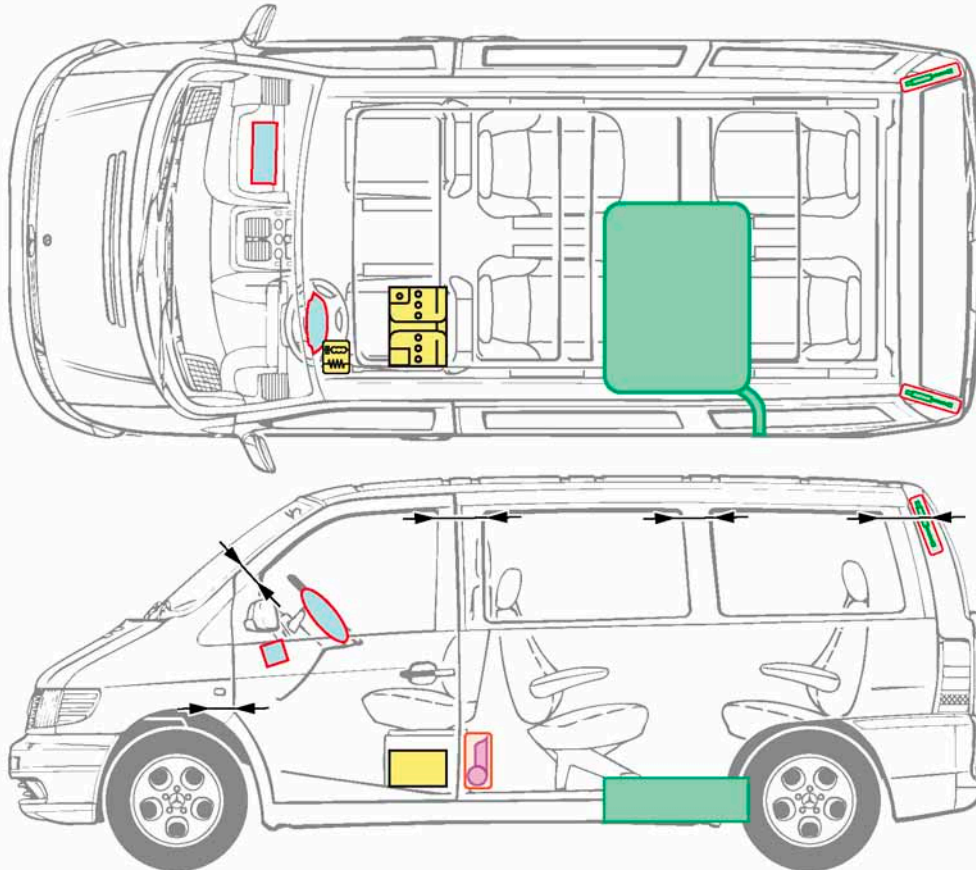

Legend



Airbag



Structural reinforcements

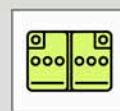

Battery

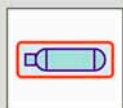

Gas generator



Rollover protection



High-voltage components



Seat belt tensioner



Fuel tank



Cutting points



Gas filled spring device



Control unit

**Viano/Vito
Van
Model 639**

as of 2003

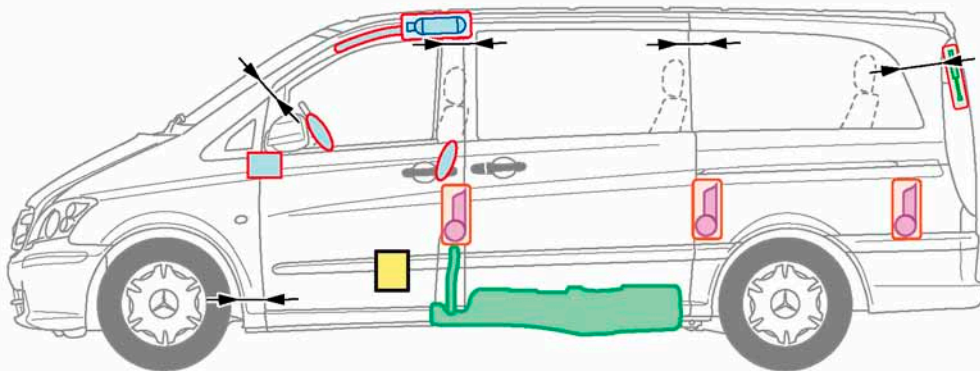
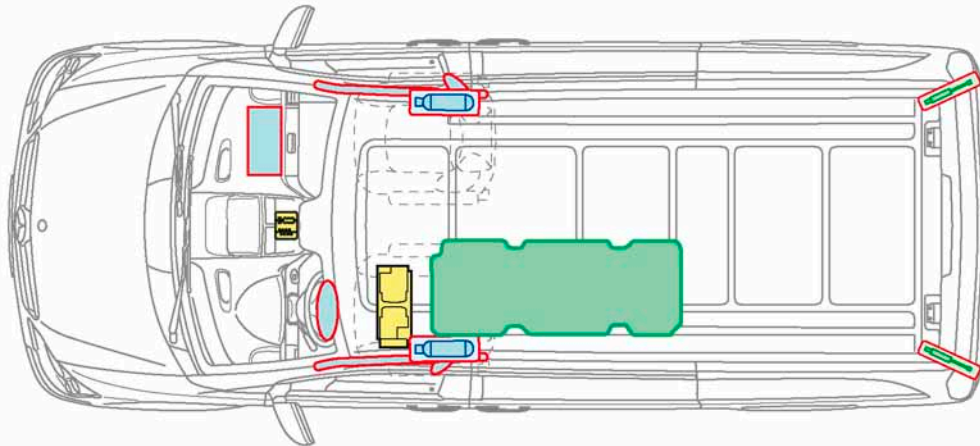

Legend



Airbag

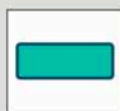

Structural reinforcements

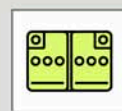

Battery



Gas generator



Rollover protection



High-voltage components



Seat belt tensioner



Fuel tank



Cutting points

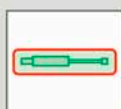

Gas filled spring device



Control unit

Viano
FUN
Model 639

as of 2003

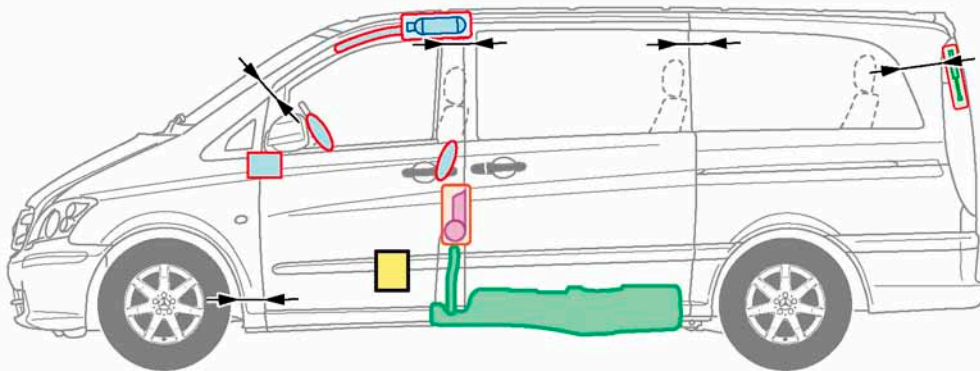
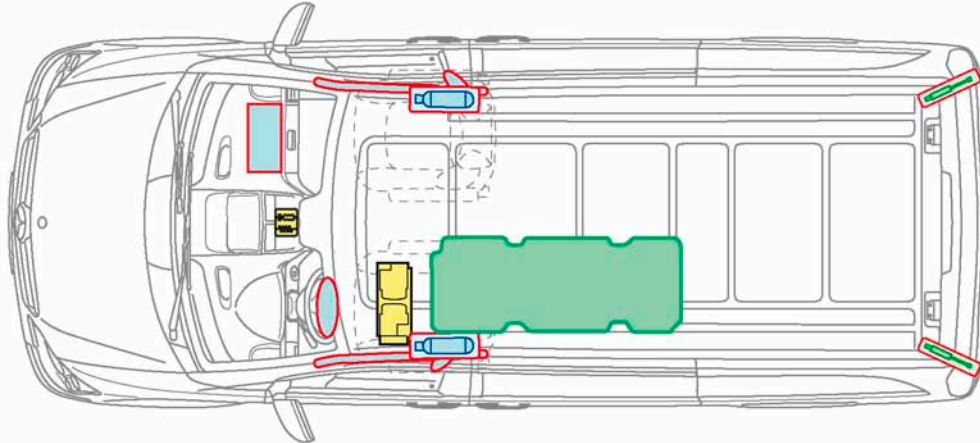

Legend



Airbag



Structural reinforcements

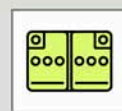

Battery



Gas generator



Rollover protection



High-voltage components



Seat belt tensioner



Fuel tank



Cutting points



Gas filled spring device



Control unit

Viano
MARCO POLO
Westfalia
Model 639

as of 2003

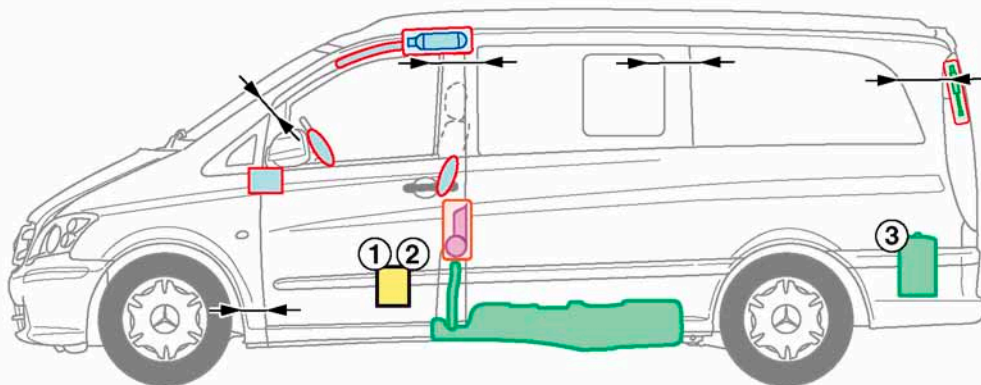
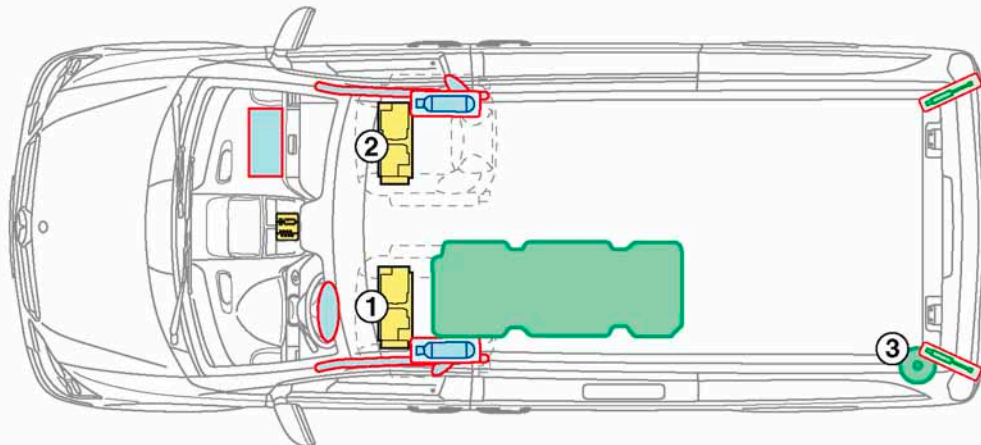

- 1 Main battery
- 2 Additional battery
- 3 Gas cylinder (Camping Gaz, 2,8 kg)

Legend



Airbag



Structural reinforcements



Battery



Gas generator



Rollover protection



High-voltage components



Seat belt tensioner



Fuel tank



Cutting points

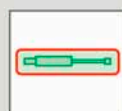

Gas filled spring device







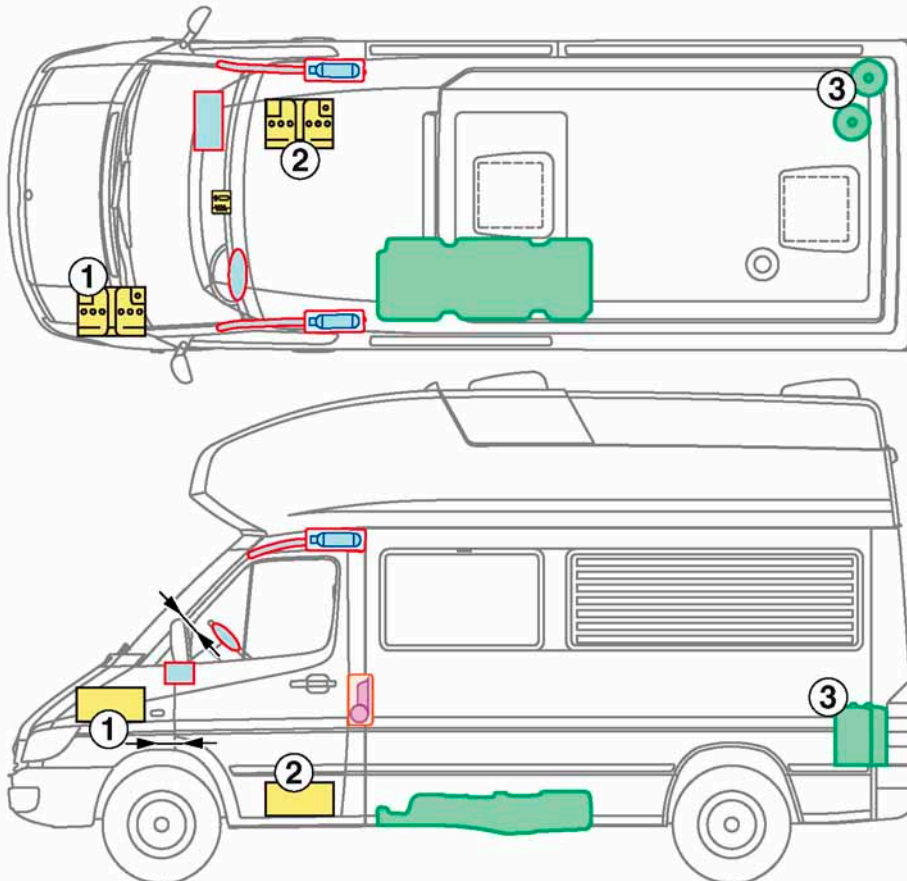



Control unit

Sprinter
JAMES COOK
Westfalia
Model
901-905
1995-2006

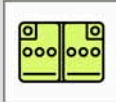
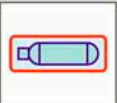

- 1 Starter battery
- 2 Additional battery
- 3 Gas cylinder (Camping Gaz, 2x5 kg)

Legend

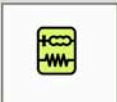
	Airbag		Structural reinforcements		Battery
	Gas generator		Rollover protection		High-voltage components
	Seat belt tensioner		Fuel tank		Cutting points
	Gas filled spring device		Control unit		





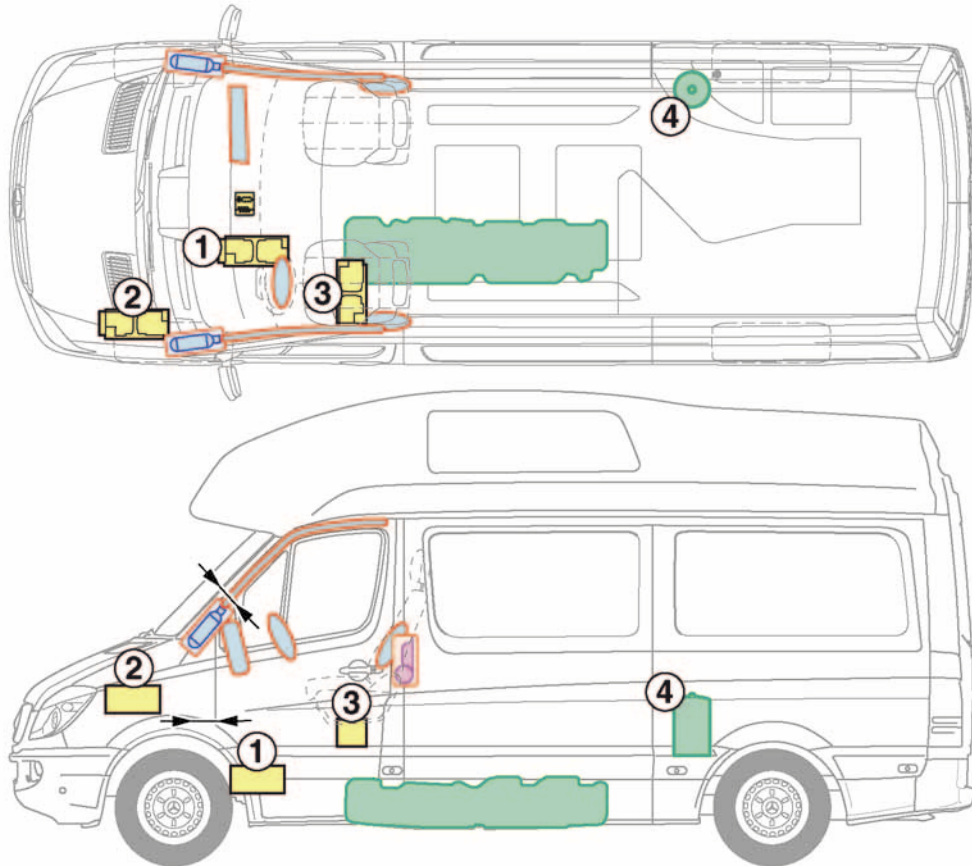



Sprinter
JAMES COOK
Westfalia
Model 906

as of 2006

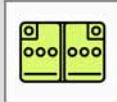
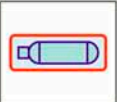

- 1 Starter battery
- 2 Additional battery (LHD)
- 3 Additional battery (RHD)
- 4 Gas cylinder (Camping Gaz, 2,75 kg)

Legend

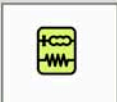
	Airbag		Structural reinforcements		Battery
	Gas generator		Rollover protection		High-voltage components
	Seat belt tensioner		Fuel tank		Cutting points
	Gas filled spring device		Control unit		

SLS
AMG
Model 197

as of 2010

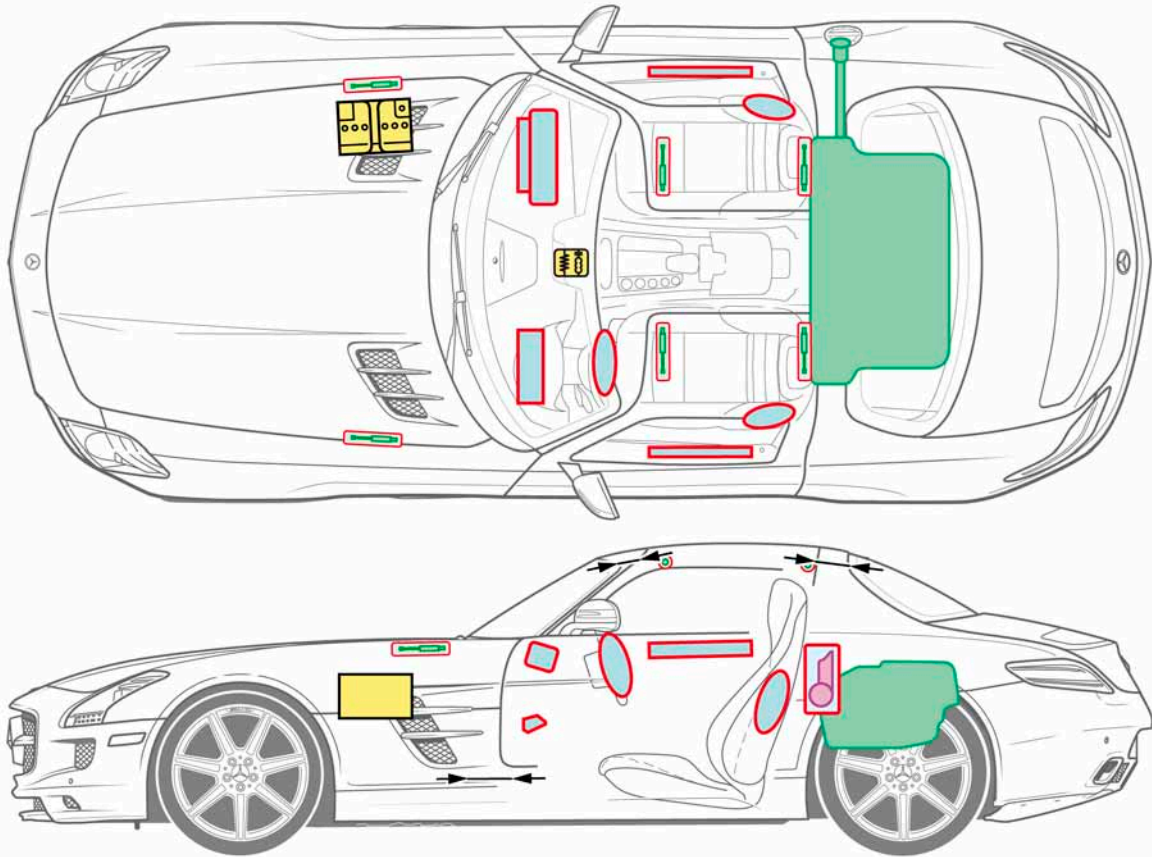

Legend



Airbag



Structural reinforcements

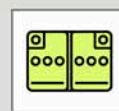

Battery



Gas generator



Rollover protection



High-voltage components



Seat belt tensioner



Fuel tank



Cutting points



Gas filled spring device



Control unit

SLS
AMG
Roadster
Model 197

as of 2011

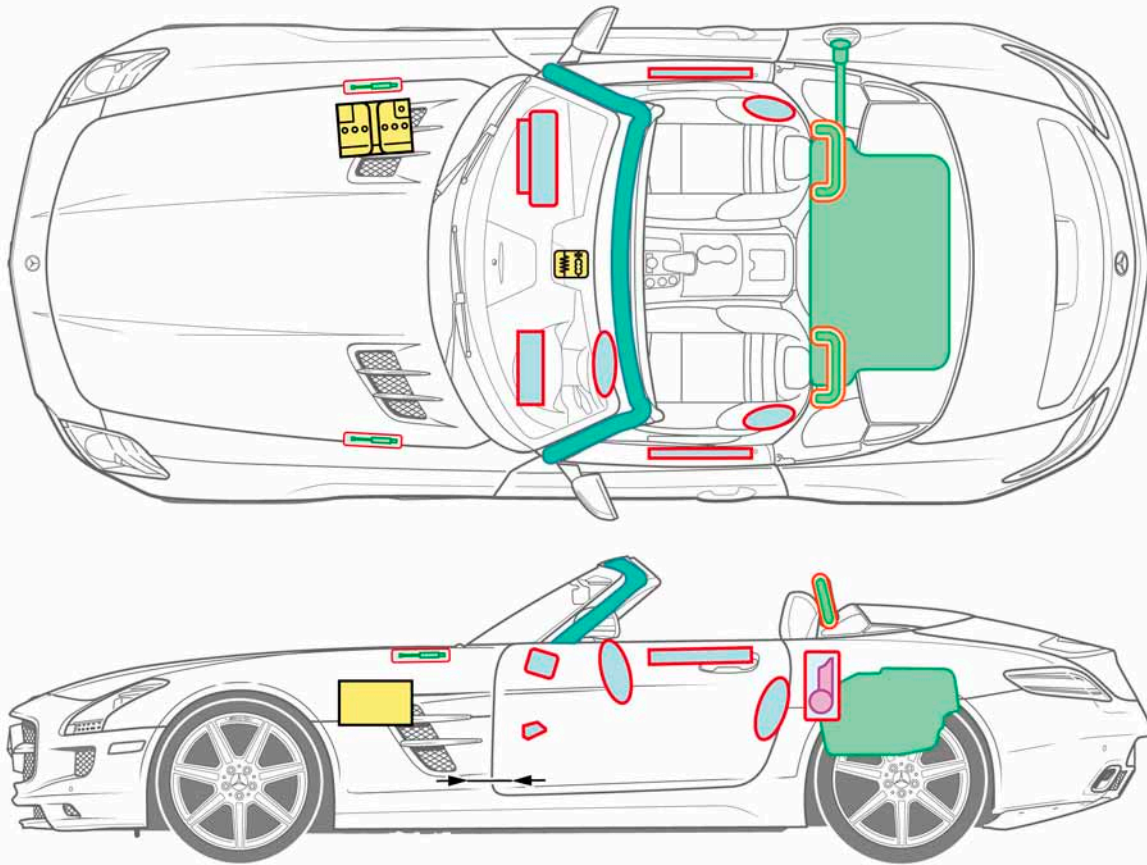

Legend



Airbag



Structural reinforcements

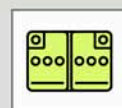

Battery



Gas generator



Rollover protection



High-voltage components



Seat belt tensioner



Fuel tank



Cutting points



Gas filled spring device



Control unit



Maybach
Sedan
Model 240

as of 2002

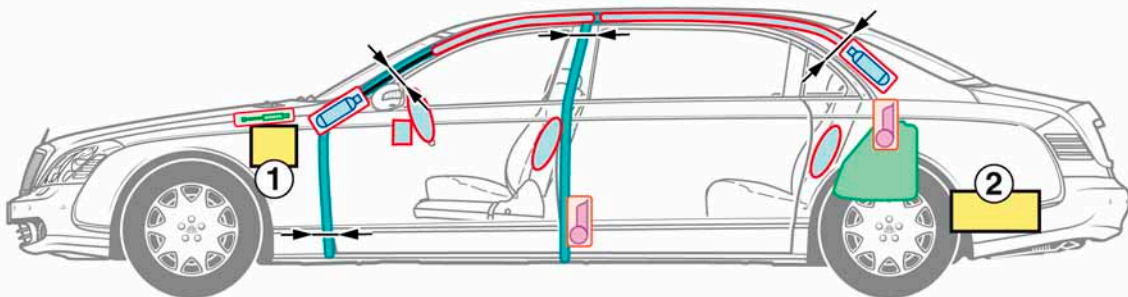
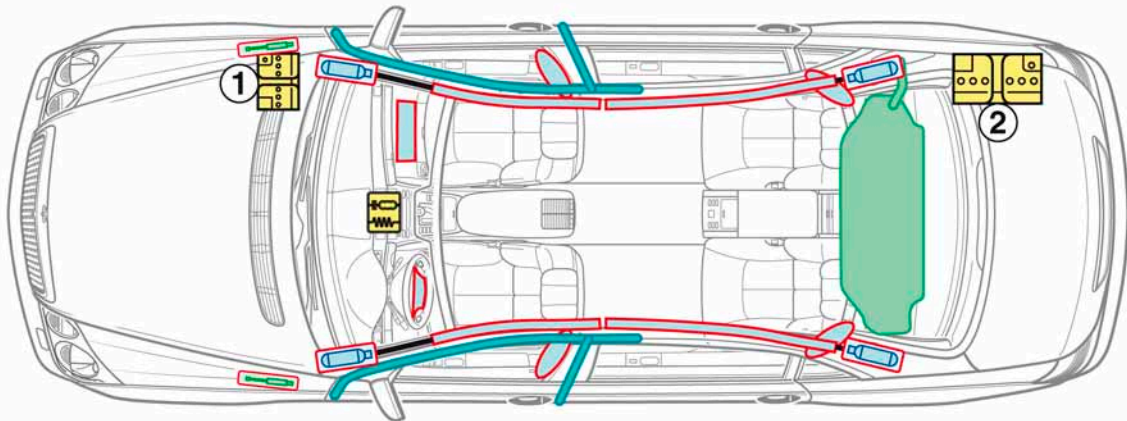

- 1 Starter battery (engine compartment)
- 2 Power supply battery (trunk)

Legend



Airbag



Structural reinforcements

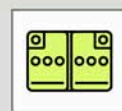

Battery



Gas generator



Rollover protection



High-voltage components



Seat belt tensioner



Fuel tank



Cutting points

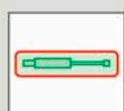

Gas filled spring device



Control unit

smart
fortwo
coupé
Model 450

1998-2007

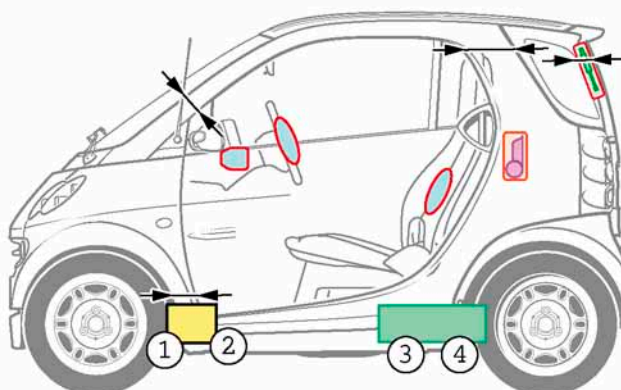
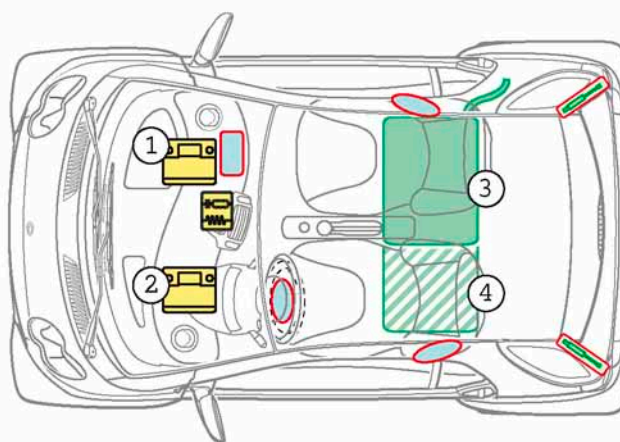

1 LHD vehicle
2 RHD vehicle

3 Fuel tank, vehicle with diesel engine
4 Fuel tank, vehicle with gasoline engine

Legend



Airbag



Structural reinforcements

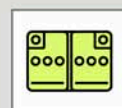

Battery



Gas generator



Rollover protection



High-voltage components



Seat belt tensioner

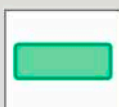

Fuel tank



Cutting points

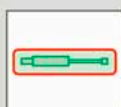

Gas filled spring device



Control unit

smart
fortwo
Cabriolet
Model 450

1998–2007

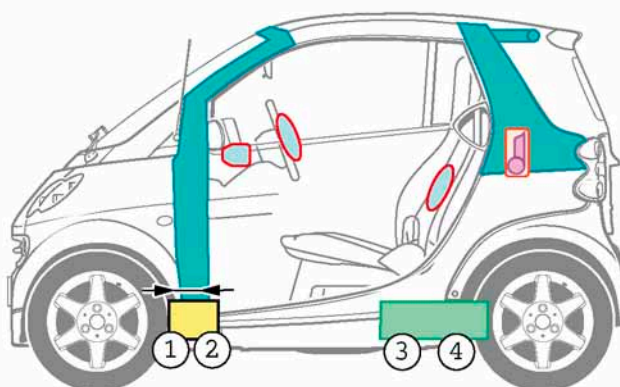
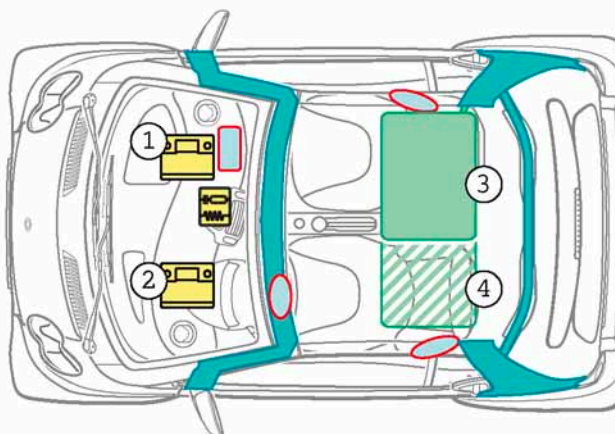

1 LHD vehicle
2 RHD vehicle

3 Fuel tank, vehicle with diesel engine
4 Fuel tank, vehicle with gasoline engine

Legend



Airbag



Structural reinforcements

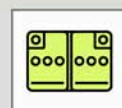

Battery



Gas generator



Rollover protection



High-voltage components



Seat belt tensioner

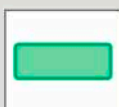

Fuel tank



Cutting points



Gas filled spring device



Control unit

smart
fortwo
coupé
Model 451

as of 2007

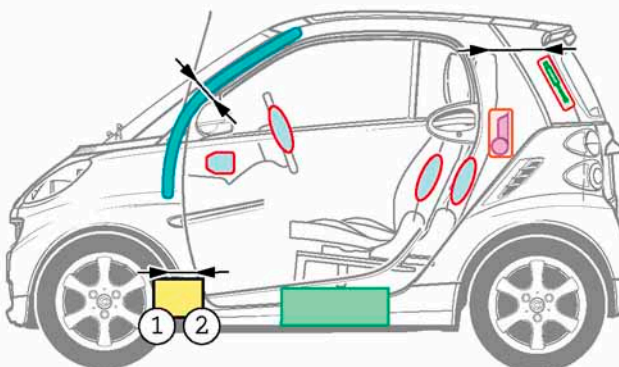
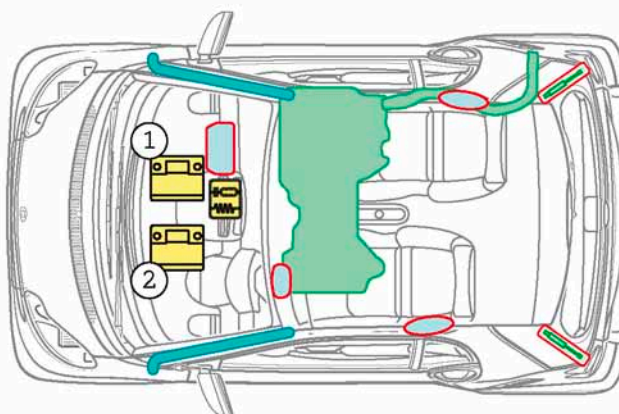

- 1 LHD vehicle
- 2 RHD vehicle

Legend



Airbag



Structural reinforcements

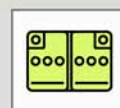

Battery



Gas generator



Rollover protection



High-voltage components



Seat belt tensioner

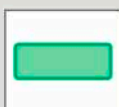

Fuel tank



Cutting points

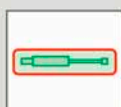

Gas filled spring device



Control unit





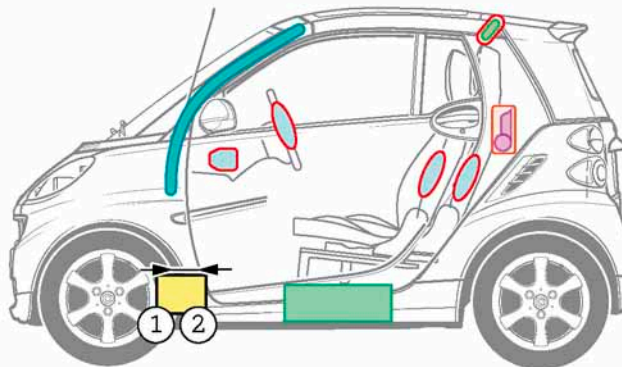
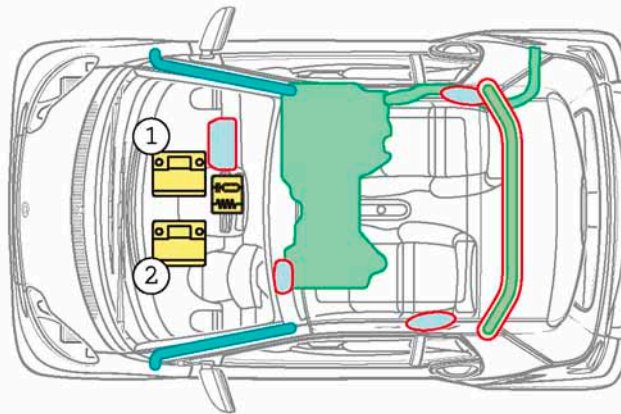



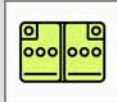

smart
fortwo
Cabriolet
Model 451

as of 2007

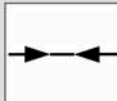

- 1 LHD vehicle
- 2 RHD vehicle

Legend

	Airbag		Structural reinforcements		Battery
	Gas generator		Rollover protection		High-voltage components
	Seat belt tensioner		Fuel tank		Cutting points
	Gas filled spring device		Control unit		

smart
fortwo
coupé
electric drive
Model 451
as of 2009

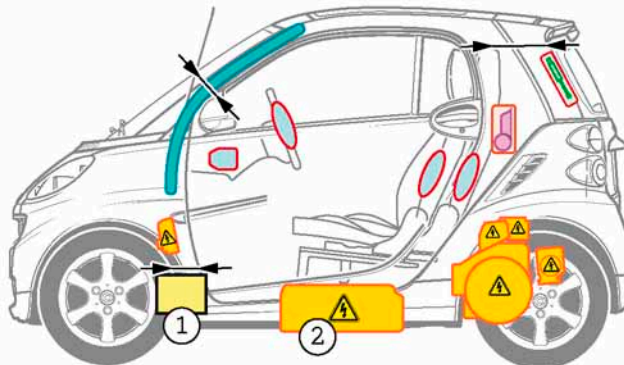
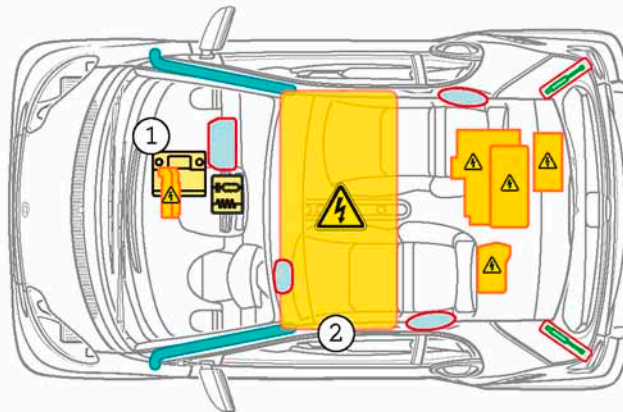

1 12 V-battery
2 High-voltage battery

Legend



Airbag



Structural reinforcements

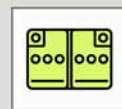

Battery



Gas generator



Rollover protection



High-voltage components



Seat belt tensioner



Fuel tank



Cutting points

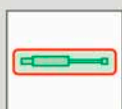

Gas filled spring device



Control unit

smart
fortwo
Cabriolet
electric drive
Model 451
as of 2009

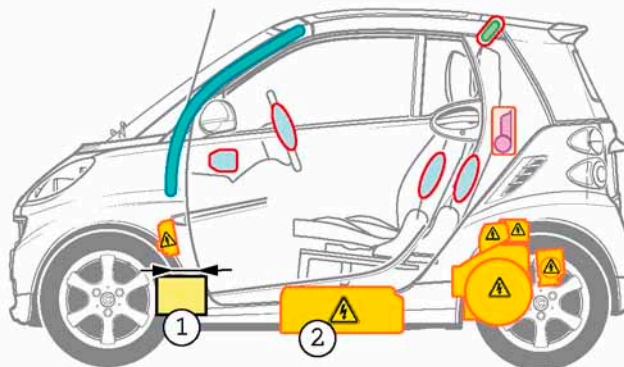
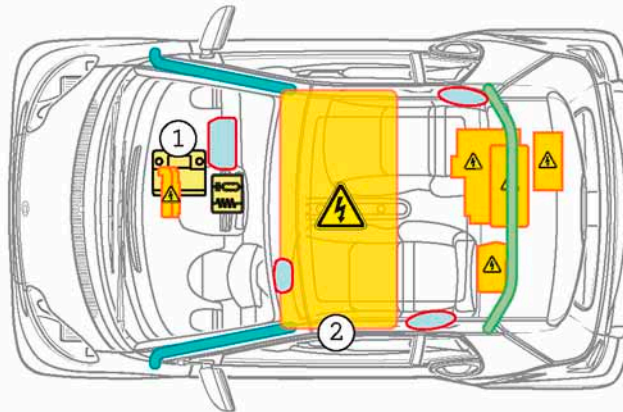
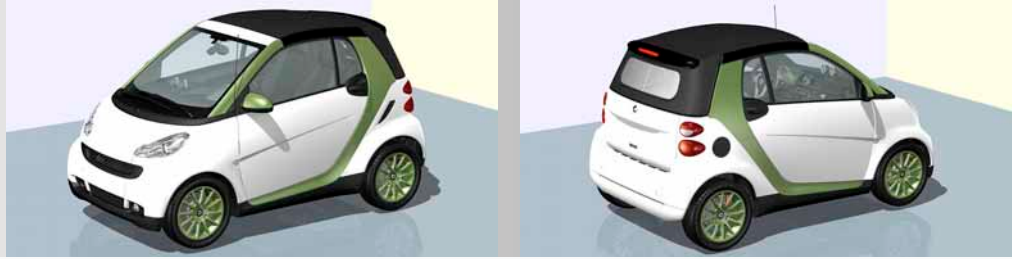

- 1 12 V-battery
- 2 High-voltage battery

Legend



Airbag



Structural reinforcements

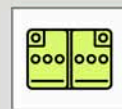

Battery



Gas generator



Rollover protection



High-voltage components



Seat belt tensioner



Fuel tank



Cutting points



Gas filled spring device



Control unit

smart
roadster
Model 452

2003-2005

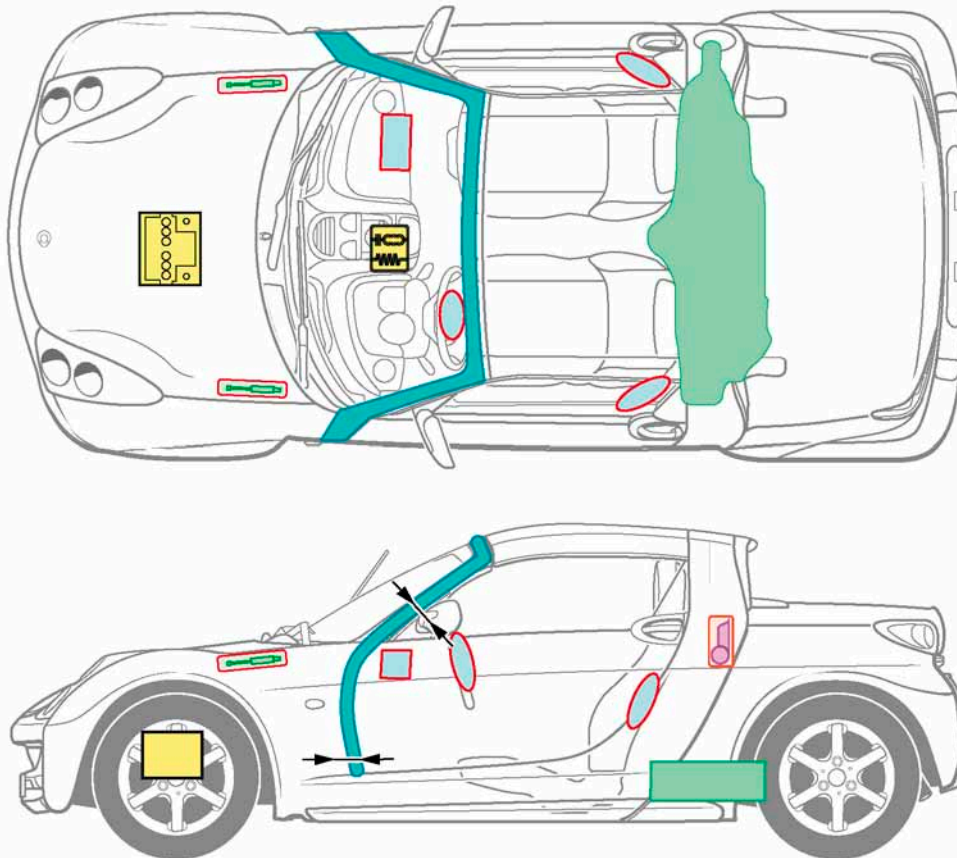

Legend

	Airbag		Structural reinforcements		Battery
	Gas generator		Rollover protection		High-voltage components
	Seat belt tensioner		Fuel tank		Cutting points
	Gas filled spring device		Control unit		

smart
roadster
coupé
Model 452

2003-2005

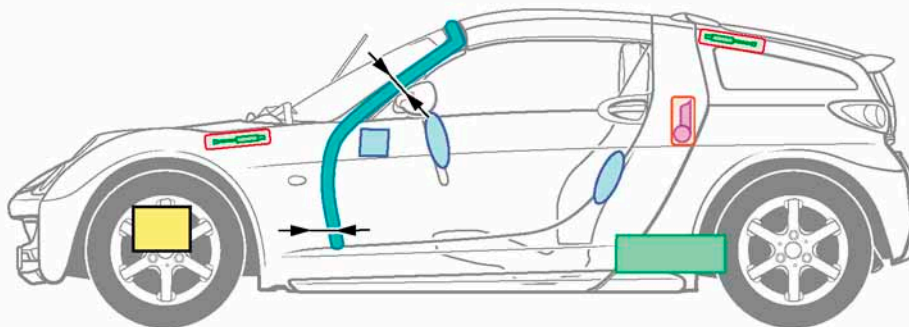
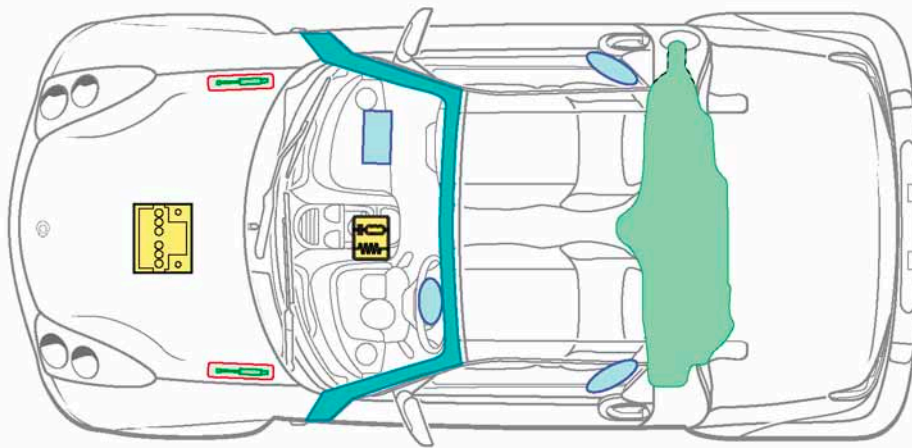

Legend

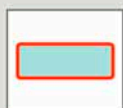

Airbag



Structural reinforcements

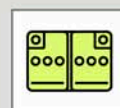

Battery



Gas generator



Rollover protection



High-voltage components



Seat belt tensioner

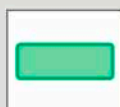

Fuel tank



Cutting points

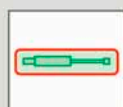

Gas filled spring device



Control unit

smart
forfour
Model 454

2004-2006

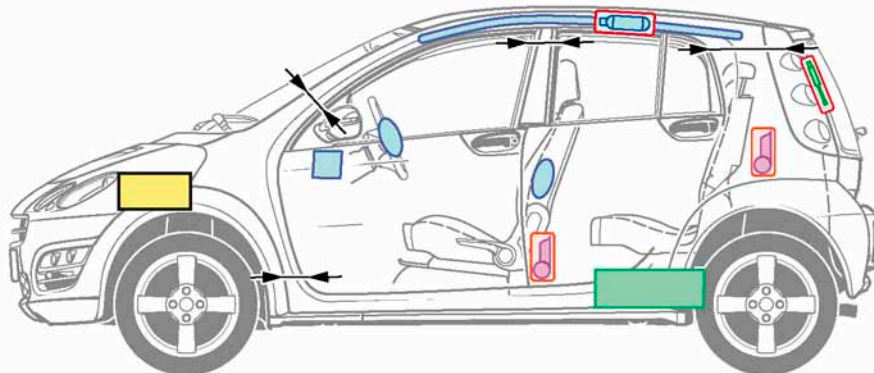
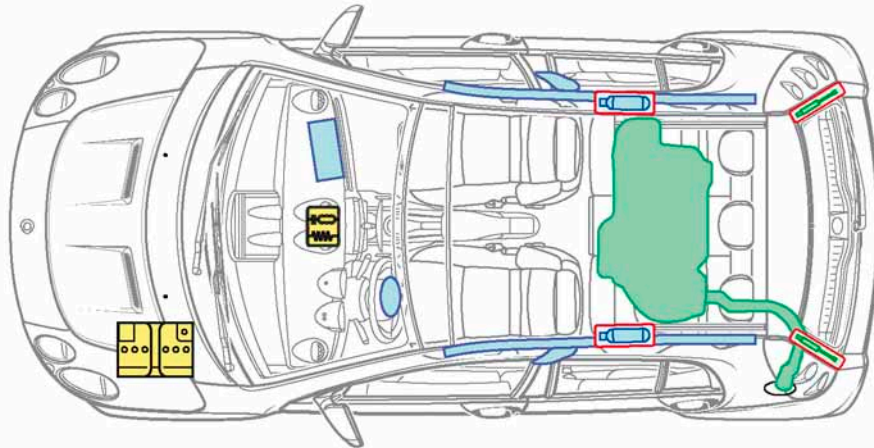

Legend



Airbag



Structural reinforcements

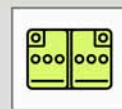

Battery

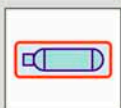

Gas generator



Rollover protection



High-voltage components



Seat belt tensioner



Fuel tank



Cutting points



Gas filled spring device



Control unit

