

# Emergency Response Guide



## Kia Carnival HEV



Movement that inspires



# Introduction

The ERG (Emergency Response Guide) provided by Kia describes emergency response operations, warnings, and precautions related to the vehicle. This publication is intended to provide necessary information for vehicle accident rescue operations and for the training and further education of the first and second responders.

Please note that the guide may be updated by Kia consistently. It is not intended for retailers, end consumers, or any other readers not mentioned in the preceding sentence.

The provided guide applies only to the Kia Carnival HEV vehicle and includes information about the location and description of high-voltage components and the vehicle's structure. However, it does not cover every scenario in emergencies.

Failure to follow the recommended procedures in emergencies may result in death or other serious injuries. It is important to read the guide in advance as it contains necessary information about the vehicle's features and other contents in the event of an accident.

## IMPORTANT INFORMATION



A WARNING indicates a situation in which harm, serious bodily injuries, or death could happen if the warning is ignored.

# Contents

1. Identification / recognition

2. Immobilization / stabilization / lifting

3. Disable direct hazards / safety regulations

4. Access to the occupants

5. Stored energy / liquids / gases / solids

6. In case of fire

7. In case of submersion

8. Towing / transportation / storage

9. Important additional information

10. Explanation of pictograms used

## Initial Response: Identify, Immobilize, and Disable

The following procedures should be used whenever you deal with a Carnival HEV at an emergency. However, all operations should be consistent with your department's standard operating procedures, guidelines, and applicable laws. When a HEV is damaged in a crash, the high-voltage safety systems may be damaged and cause a potential high-voltage electrical shock hazard. Exercise caution and wear appropriate personal protective equipment (PPE) and safety gears including high-voltage safety gloves and boots. Remove all metallic jewelry, including watches and rings.

### **WARNING**

The Carnival HEV is a hybrid electric vehicle. Emergency responders should properly respond to emergency scenarios involving the Carnival HEV and exercise extreme care to avoid contact with the high-voltage system within the vehicle.

## Engine Room

A "HYBRID" logo is also marked on the engine cover under the hood.



## Identifying a Carnival HEV

### VIN

The Vehicle Identification Number (VIN) is the number used in registering your vehicle and in all legal matters pertaining to its ownership, etc.

The number is punched on engine compartment frame as shown in the drawing.



### VIN Label (if equipped)

The VIN is also on a plate attached to the top of the dashboard. The number on the plate can easily be seen through the windshield from outside.

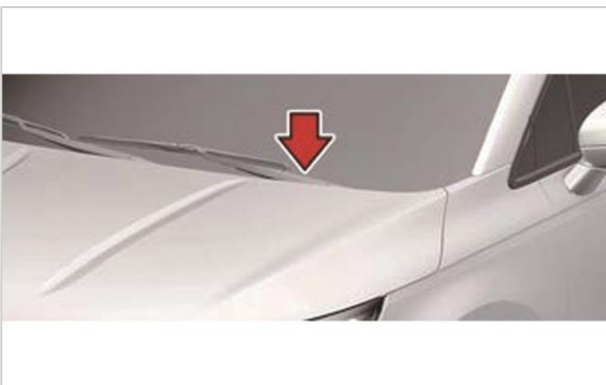

### Vehicle certification label

The vehicle certification label attached on the driver's (or front passenger's) side center pillar shows the VIN.

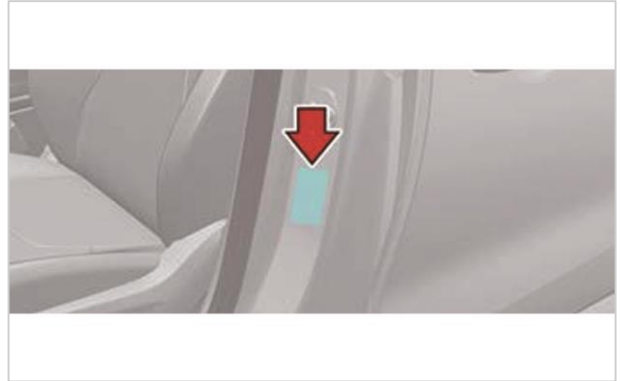

## Carnival HEV Cluster Instrument Panel

The Carnival HEV cluster instrument panel displays the HEV specific features such as high voltage battery SOC (State of Charge) as below.

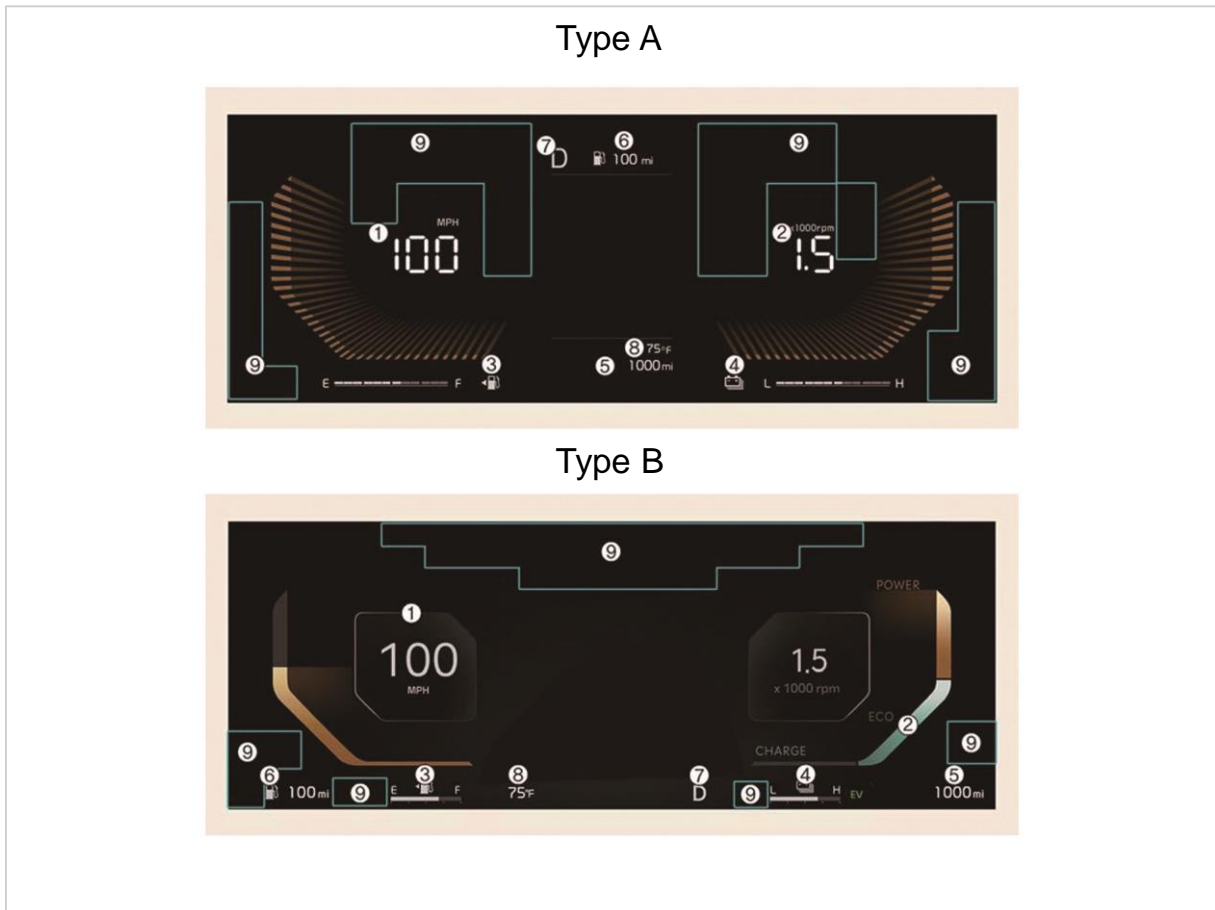

1. Speedometer
2. Tachometer / Power gauge
3. Fuel gauge
4. Hybrid battery SOC gauge
5. Odometer
6. Distance to empty
7. Transmission shift indicator
8. Outside temperature gauge
9. Warning and indicator lights

### 2.1 Immobilization

The next step is to immobilize the vehicle to prevent accidental movement that can endanger response personnel or civilians. When the Carnival HEV is damaged in a crash, the vehicle may appear to be shut off due to no engine sounds even when it is actually not. When the "READY" mode light is up on the Instrument Panel, the vehicle can move silently by using the electric motor. Responders should approach the vehicle from the sides and stay away from the front or rear as they are potential paths for vehicle movement. Be sure to immobilize the vehicle in the following manner.

#### 1. Chock the wheels



2. Put the vehicle in P (Park) position by pressing the 'P' button.



#### 3. Set the Electronic Parking Brake (EPB)



#### **WARNING**

- When installing a block or jack, avoid high-voltage cable, high-voltage battery, and fuel system (exhaust system).
- If high-voltage components or cables are exposed, do not place any support on them.

### 2.2 Vehicle Stabilization

Use standard stabilization (lift) points, as shown below. Always check the connection to the structural component of the vehicle and avoid placing cribbing under high-voltage cables and other areas not normally considered acceptable.



## Disabling vehicle

The final step in the initial response process, after immobilizing the vehicle, is to disable the vehicle, its SRS components, and the high-voltage electrical system. To prevent current from flowing through the system, use one of the following procedures to disable the vehicle.

### Case 1:

1. Engine – OFF
2. 12 V battery disconnection
3. High-voltage shut off

### Case 2\*:

1. Fuse removal (Fuse box)
2. 12 V battery disconnection
3. High-voltage shut off

\*In case of emergency

SRS : Supplemental Restraint System

## 3.1 Disabling the System – Smart Key System and “ENGINE” START/STOP Button

1. Confirm the status of the READY light on the instrument panel. If the READY light is on, the vehicle is ON.

a) If the READY light is NOT on, the vehicle is off. Do not push the “**ENGINE**” **START/STOP** button because the vehicle may start (go into READY mode).

b) To turn OFF the system, press the 'P' (Park) button on the shifter dial and press the ENGINE START/STOP button.

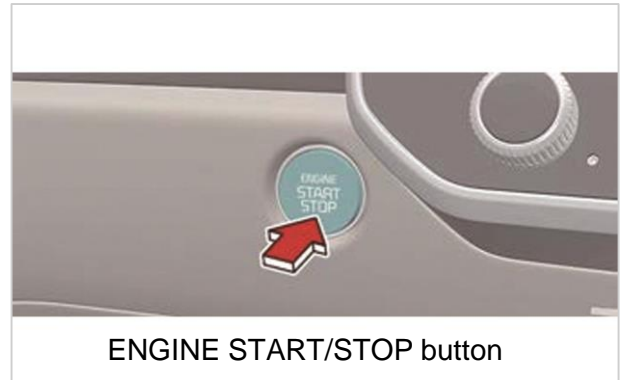

2. If necessary, lower the windows, unlock the doors, and open the trunk as required before disconnecting the 12 V battery. Once the 12 V battery is disconnected, power controls will not operate.

3. Before disconnecting the 12 V battery, remove the smart key at least 2 meters (7 feet) away from the vehicle to prevent accidental restart.

4. Follow the procedures below to remove the service interlock connector and disable the high voltage battery:

#### Disable the high voltage battery

1. Disconnect the positive (+) connector (A) of the auxiliary battery (12 V).

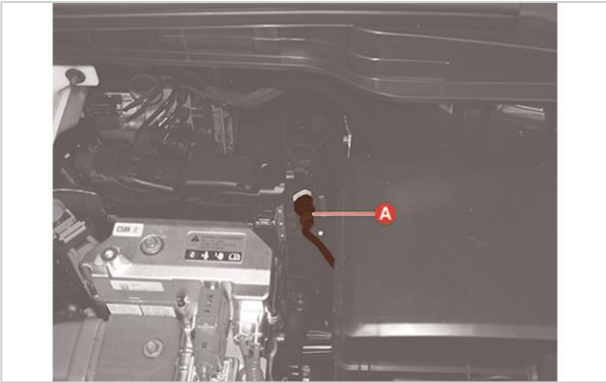

#### NOTE

The auxiliary battery (12 V) is built into the floor console. So disconnect the 12 V positive (+) connector located in the engine room for 12 V power shut-off.

2. Remove the engine room fuse box cover (A).



3. Pull the service interlock (A) up to disengage the high voltage system, ensuring the whole fuse is NOT removed from the junction box.

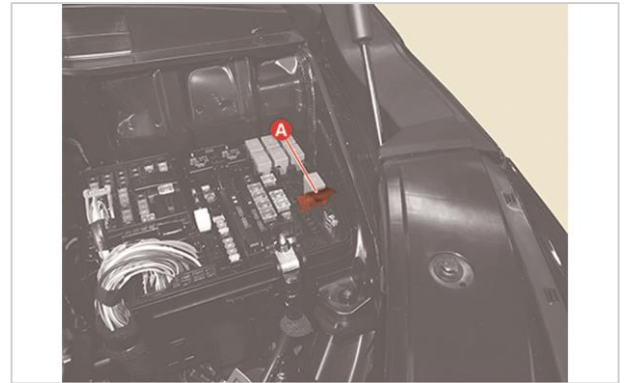

#### **WARNING**

Wait more than 3 minutes for capacitor in the inverter to be discharged completely after disengaging (pulled up) the high voltage service interlock connector.

#### NOTE

The high voltage service interlock connector cannot be completely removed.

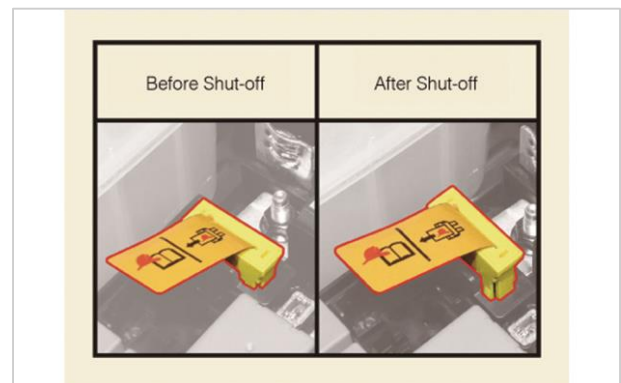

4. Measure the voltage between the inverter terminals to check that the capacitor in the inverter is discharged completely.

(a) Disconnect the battery power cable (A) from the high voltage junction box.



(b) Measure the voltage between the inverter (+) and (-) terminals.

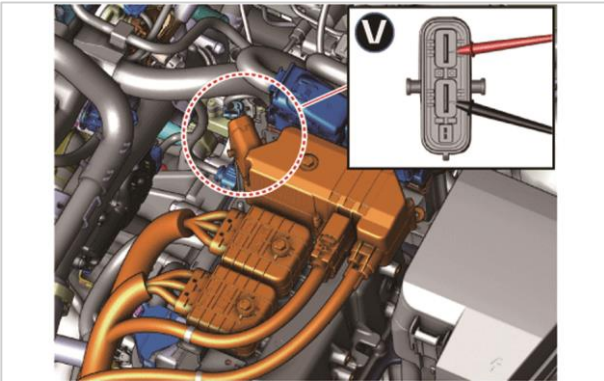

#### **WARNING**

If the voltage of 30 V or higher is measured, check if the high voltage service interlock connector is disengaged (pulled up). If the voltage of 30 V or higher is measured even though the high voltage service interlock connector is removed, there may be a significant problem with the high voltage circuit. In this case, perform DTC and do not touch the parts related to the high voltage system.

#### **NOTE**

Check the weld flag with the KDS.

#### 3.2 Disabling the system – IG (Ignition) Fuse Removal

1. Open the hood.
2. Remove the engine room fuse box cover.
3. If necessary, lower the door window, unlock the doors, and open the tailgate as required, before disconnecting the 12V battery. Once the 12V battery is disconnected, power controls will not operate.
4. In the event the vehicle is unable to be disabled by using the “ENGINE” START/STOP Button, use the fuse puller located in the engine room fuse box and pull both the IG1 and IG2 Fuse from the engine room fuse box. If the IG fuses cannot be found, pull out all of the fuses and relays in the fuse box.



Note that the actual engine room in the vehicle may differ from the picture.

Engine room fuse box  
 - The actual engine room in the vehicle may differ from the picture.

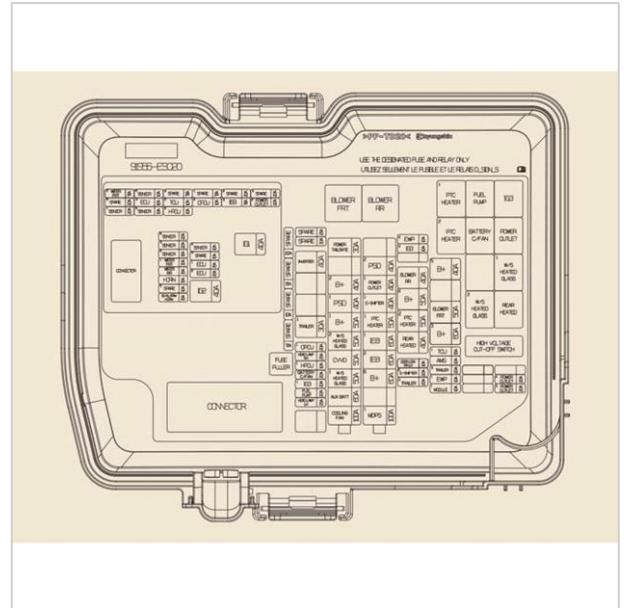

5. Disengage the service interlock connector by pulling up and disable the high-voltage battery.

If previously mentioned methods of disabling the vehicle’s system are unsuccessful, the accidental deployment of undeployed airbags and electric shock from high-voltage components may happen during any emergency procedures involving the HEV vehicle.

#### **WARNING**

Electrocution risk

- Before engaging in any emergency response procedures, ensure the vehicle is disabled and wait 5 minutes to allow the capacitor in the high-voltage system to be discharged to avoid electrocution.
- Exposed cables or wires may be visible inside or outside the vehicle. Never touch the metal chassis wires, cables, connectors, or any electric components before disabling the system and/or being shorted to the vehicle chassis.

Failure to follow these instructions will lead to serious bodily injuries or death by electrocution.

### 4.1 Rescue Operations

The Carnival HEV is an eco-friendly vehicle. Because of the high-voltage components, the first responders should pay special attention when they rescue occupants in the car. Before performing rescue operations, the first responders should “Identify, Immobilize, and Disable“ the vehicle as explained in sections on emergency procedures.

### 4.2 Rescue Tools and Procedures

When responding to an incident involving the Carnival HEV, we recommend that the first responders follow their organization’s standard operating procedures for dealing with vehicle emergencies. When the first responders cut the vehicle, they should always pay special attention to the airbag system, orange-colored high-voltage cables, and other high-voltage components so that the parts are not damaged and prevent a risk of explosion or electrocution.

### 4.3 Location of Ultra-high Strength Steel

In these images, high strength steel is used in the areas colored in blue and ultra-high strength steel is used in the red colored areas. Depending on the tools used, ultra-high strength steel can be challenging or impossible to cut. If necessary, use a workaround technique.

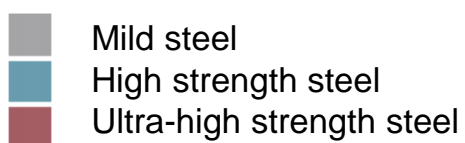
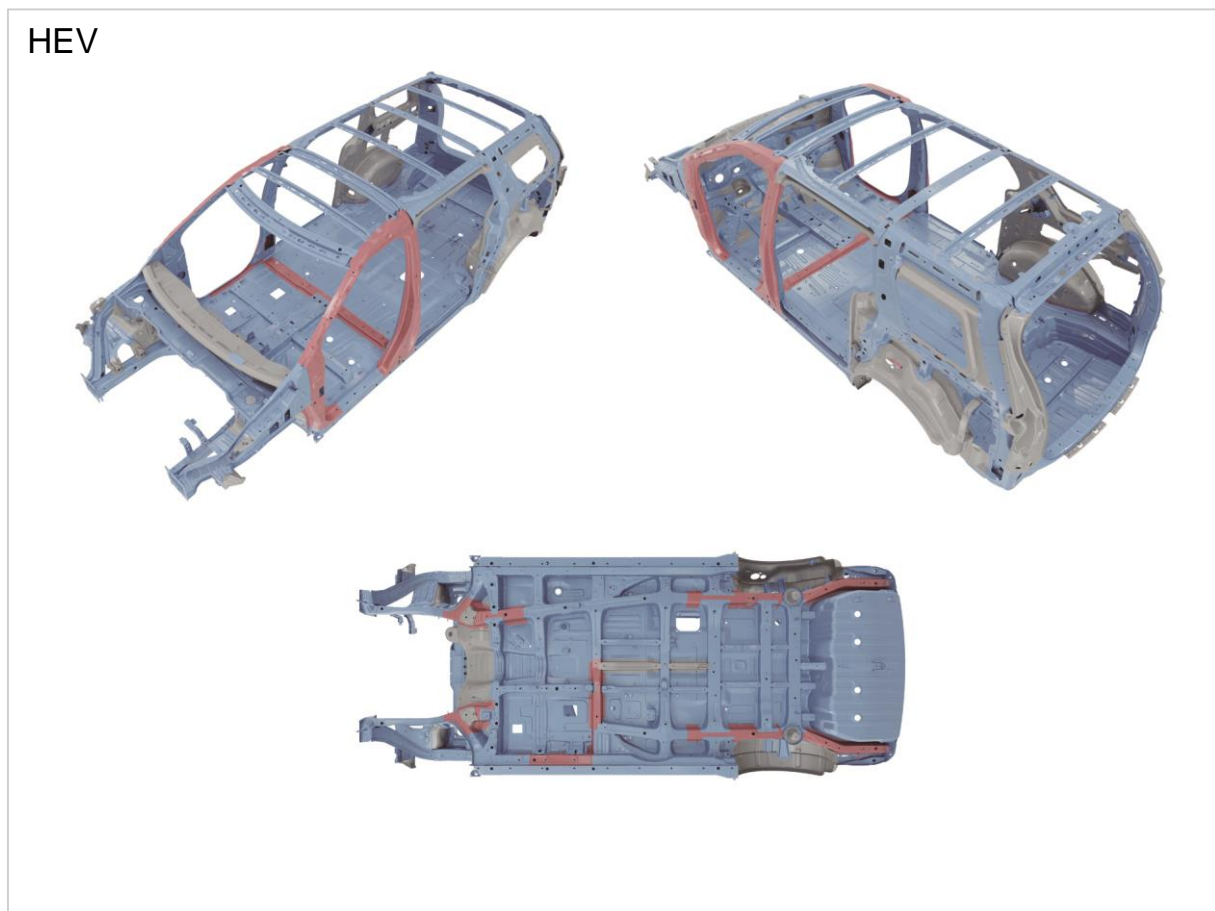













## 4. ACCESS TO THE OCCUPANTS

### 4.4 Occupants Rescue Guide

When dealing with an emergency, refer to the components as below.  
Do not cut the body near the airbag, high-voltage cable, and fuel system.



 Supplemental Restraint System Control Module (SRSCM)	 Airbag	 Airbag Inflator
 High-voltage cable	 Seat belt pretensioner	 Air-conditioning line
 High-voltage battery	 Fuel tank	 Ultra-High Strength Steel
 12 V battery	 Air-conditioning component	 High-voltage component
	 Cable Cut (with the service plug that can disable the high-voltage system)	

## 5.1 High-voltage System

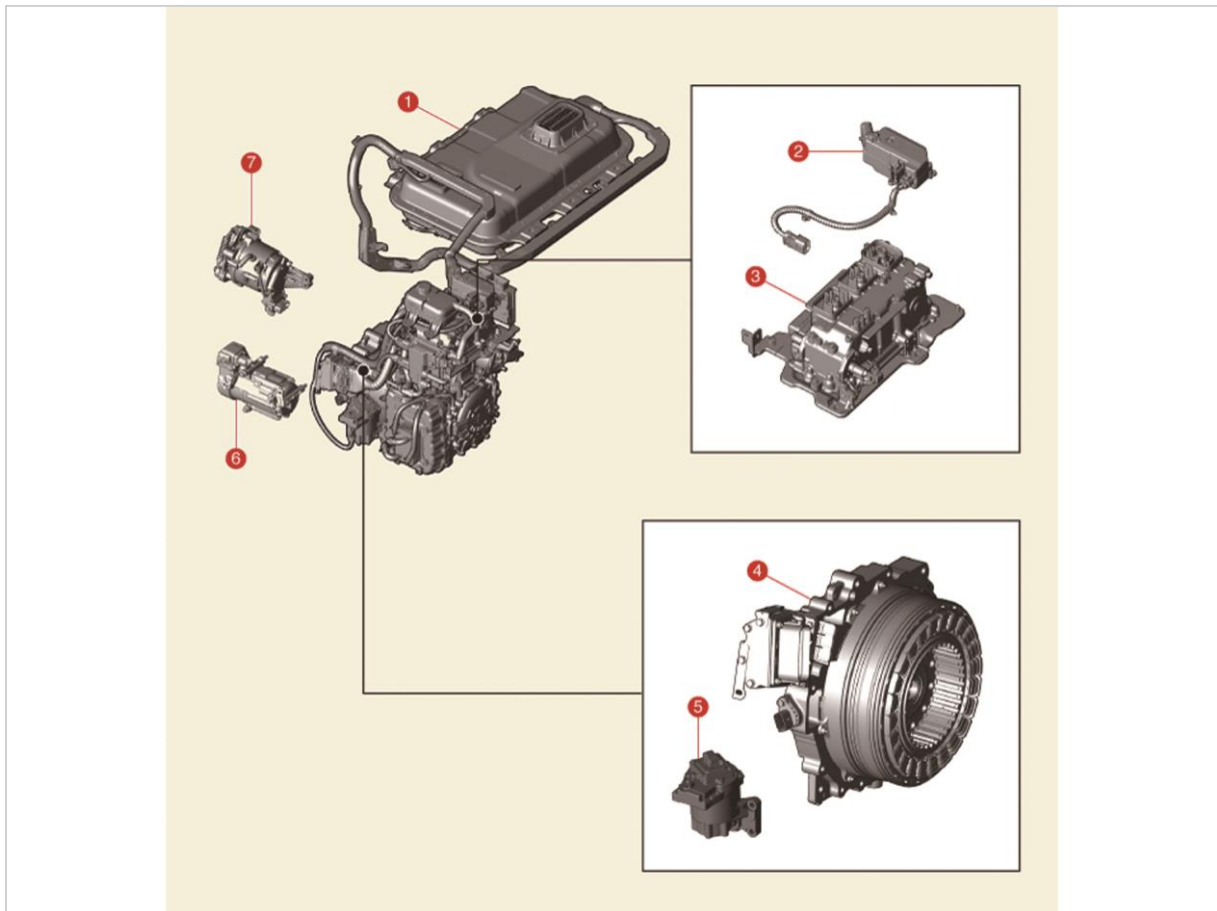

- 1. Battery System Assembly (BSA)
- 2. High-Voltage Junction Box
- 3. Hybrid Power Control Unit (HPCU)
- 4. Hybrid Drive Motor Assembly

- 5. Electric Oil Pump (EOP)
- 6. Electric A/C Compressor
- 7. Hybrid Starter Generator (HSG)

## Carnival HEV Specification

Capacity	5.5 Ah
Voltage	270 V
Energy	1.49 kWh

### 5.1 High-Voltage System

#### Hybrid Drive Motor Assembly

The HEV motor converts electrical energy into motive force with a Max. power of 72Hp (54kW) and Max. torque of 224lb-ft (304N·m).



#### HPCU (Hybrid Power Control Unit)

The HPCU includes an Inverter and LDC (Low Power DC-DC Converter) in one housing. The inverter converts DC to AC to supply electricity to the motor. It also converts AC to DC to charge the high-voltage battery. The LDC transfers high-voltage electricity to 12 volts to charge 12 V auxiliary battery.



#### High-Voltage Battery

High-Voltage battery modules supply and store electric energy from the traction motor and it is a Lithium-ion polymer battery with specifications, 270V /5.5Ah / 1.49kWh.

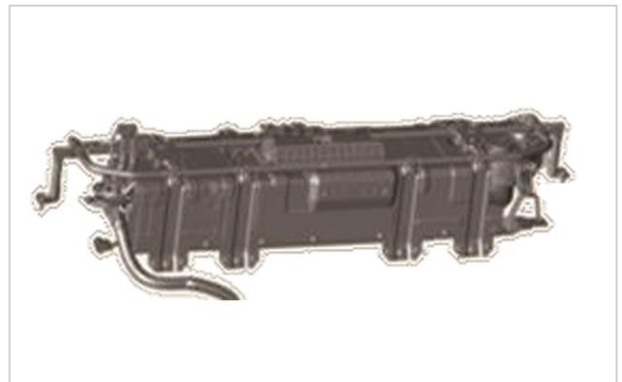

#### HSG (Hybrid Starter Generator)

The HSG restarts the engine in the HEV modes and also charges the high-voltage battery while driving as this is the generator for the hybrid vehicle.



### 5.2 High-Voltage (HV) Orange Cabling

The High-Voltage (HV) cabling is orange, as per Society of Automotive Engineers (SAE) standards. Cables run under the floor of the vehicle and connect the High-Voltage Battery to the HPCU, Motor, LDC, Inverter, A/C compressor, and other High-Voltage components located on the front of the vehicle.

You can identify the vehicle as an HEV vehicle with the presence of orange cables under the hood, in the under-floor battery compartment, or HV cables under the car.

### **WARNING**

#### High-Voltage Power Cables

- Never cut or disconnect the high-voltage orange cabling and connectors without disabling the HV system at first by removing the service interlock connector. (refer to page 7)
- Exposed cables or wires may be visible inside or outside the vehicle. Never touch the metal chassis wires, cables, connectors, or any electric components before disabling the system and check them to be shorted to the vehicle chassis.

Failure to follow these instructions will lead to serious bodily injuries or death by a electrical shock.



### 5.3 Fuel (Gasoline)

Carnival HEV has a 1.6L 4 cylinder turbo engine. The fuel type is gasoline, which is stored in the fuel tank and delivered through the fuel line. When dealing with an emergency, be careful not to cut the fuel line and tank.

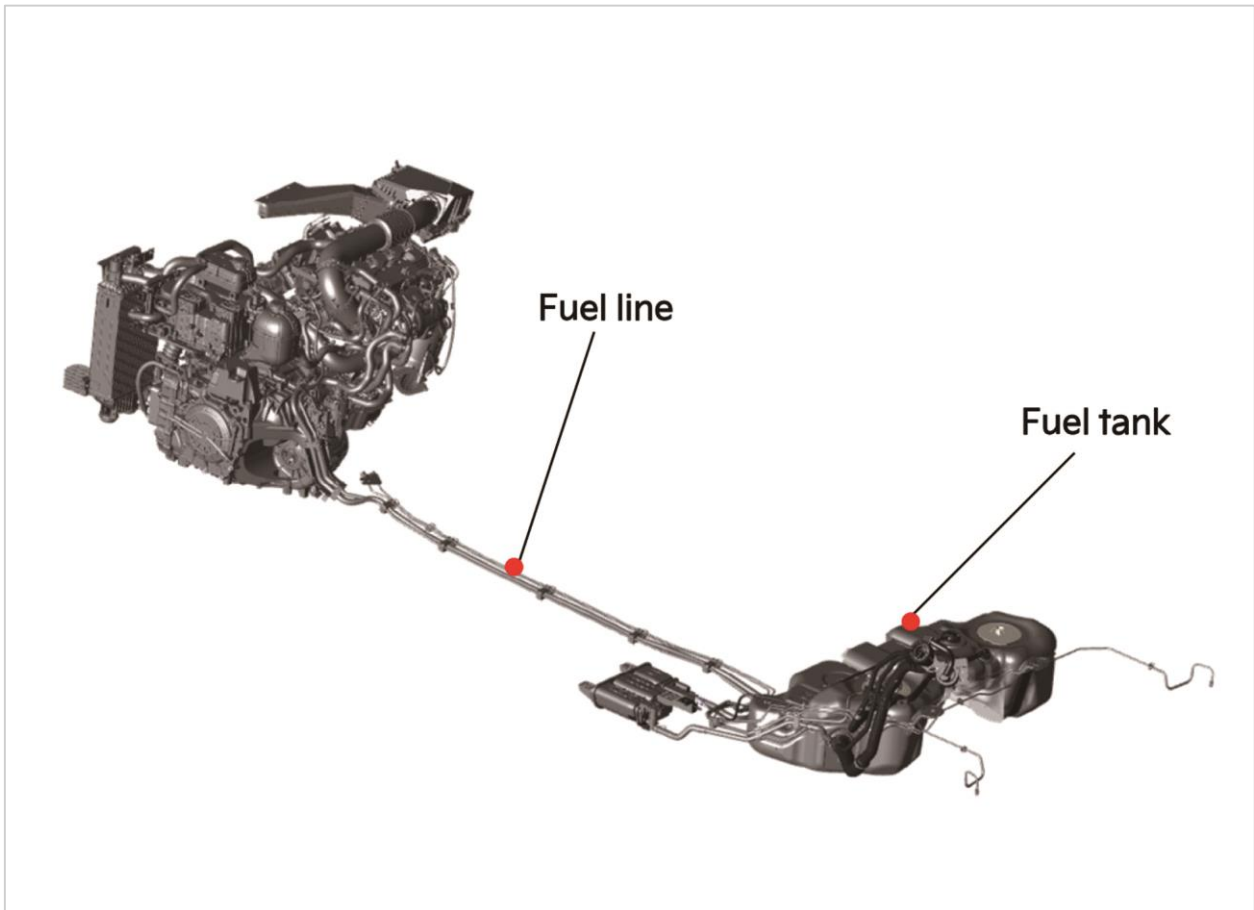

### 6.1 Firefighting Operations

Strict precautions must be taken while conducting firefighting operations following Reasons:

- Lithium-ion Polymer batteries contain electrolyte that can vent, ignite, and spark when they are exposed to temperatures above 300° F (150° C).
- Vehicle may burn rapidly with a flare-burning effect.
- Even after the high-voltage battery fire appears to have been extinguished, renewed or delayed fire can occur.
  - Use a thermal imaging camera to ensure the high-voltage battery is completely cooled before leaving the spot of the accident.
  - Always inform the second responders that there is a risk of the battery re-igniting.
  - In a fire, submersion, or a collision that damages the high-voltage battery, always store it in an open area with no exposures within 50 feet (15m).
- A burning battery could release hydrogen fluoride, carbon monoxide, and carbon dioxide gasses. Use full-face self-contained breathing apparatus (SCBA) approved by NIOSH/MSHA with full protective gear. Even if the high-voltage battery pack is not directly involved in a vehicle fire, approach the vehicle very carefully.

NIOSH: National Institute of Occupational Safety & Health  
MSHA: Mine Safety and Health Administration

### 6.2 Extinguishers

- Small fires not involved with the high-voltage battery should be extinguished with an ABC fire extinguisher. (ex. A fire caused by wiring harnesses or electrical components, etc.)
- Do not attempt to extinguish fires that involve the high-voltage battery with a small amount of water as this can result in electrocution. Fires that involve the high-voltage battery should be extinguished with a large amount of water(Max 100,000 liter) to cool the high-voltage battery. Fire fighters should not hesitate to pour a larger amount of water on the vehicle in such scenarios. Make sure the battery is fully cooled to avoid fire re-ignition.

## 6.3 How to Deal with the Situation

When fire:

Extinguish the fire with a large amount of water. Don't use seawater or salt water. It can generate the toxic vapor or cause the re-ignition.

When damaged battery or fluid leak:

- Disconnect 12 V battery (-) terminal.
- Disable the high-voltage system.
- Neutralize the battery by applying a large volume of water. (It doesn't discharge the battery)
- Discharge the battery.

\*If electrolyte solution leakage, or any damage to the high-voltage battery casing is observed.

### 6.3.1 Vehicle Fire

- Use a large volume of water (max. 100,000 liters). Water must cool down the battery.
- If you put water into the high-voltage battery casing, it will be better to cool down the battery. (But, never attempt to penetrate the high-voltage battery or its casing to apply water.)
- Putting water into the high-voltage battery can be difficult due to the battery case.
- Put water through the hole that might be made due to the accident or fire.

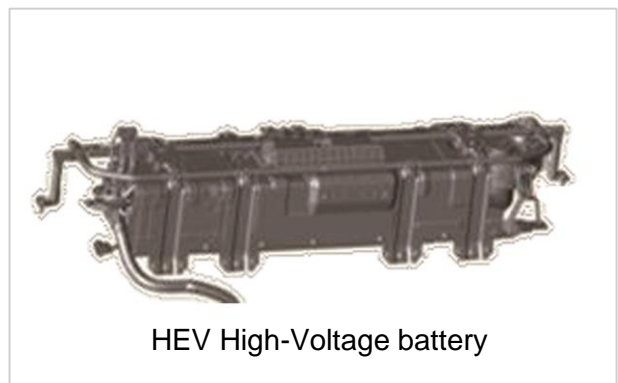
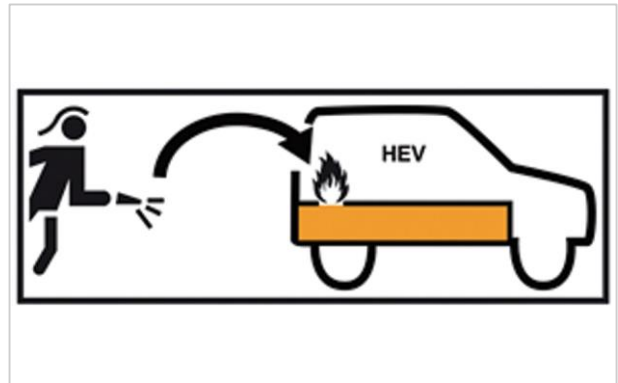

HEV High-Voltage battery

### 6.3.2 High-Voltage Battery Damage and Fluid Leaks

If electrolyte solution leakage, or any damage to the Lithium ion battery casing is observed, the first responders should wear appropriate Personal Protective Equipment (PPE) and attempt to neutralize the battery by applying a large volume of water to the battery pack. The neutralization process helps stabilize the thermal condition of the battery pack but does not discharge the battery.

- Do not put any smoke, spark, flame around the vehicle.
- Do not touch or step on the spilled electrolyte.
- If electrolyte leak occurs, wear appropriate solvent resistant PPE and use soil, sand, or a dry cloth to clean up the spilled electrolyte. Be sure to adequately ventilate the area.

 **WARNING**
**Electrolyte Irritation**

The high-voltage battery contains electrolyte solution. To avoid exposure to electrolyte solution and serious personal injuries, always wear appropriate solvent resistant PPE (Personal Protective Equipment) and SCBA (Self-Contained Breathing Apparatus).

- Electrolyte solution is an irritant to the eyes. In the event of contact with eyes, rinse with plenty of water for 15 minutes.
- Electrolyte solution is a skin irritant. Therefore, in the event of contact with skin, wash off with soap.
- Electrolyte liquid or fumes contacting with water will create vapors in the air by oxidization. These vapors may irritate the skin and eyes. In the event of contact with vapors, rinse with plenty of water and consult a doctor immediately.
- Electrolyte fumes (when inhaled) can cause respiratory irritation and acute intoxication. Inhale fresh air and wash your mouth with water. Consult a doctor immediately.

## 6.4 High-voltage Battery Re-ignition by Stranded Energy

Damaged cells in the high-voltage battery can cause thermal run away\* and re-ignition. To prevent re-ignition, the first responder and second responder need to be aware of the risk of stranded energy\* which remains in the damaged cells and leads to re-ignition.

\*Thermal runaway: The cause of thermal runaway is generally short circuiting inside a battery cell and a resulting increase in the cell's internal temperature.

Battery produces heat with thermal runaway and it can spread from one battery cell to other cells, in a domino effect.

\*Stranded energy : Energy remains inside any undamaged battery cells after the accident. That stranded energy can cause a high-voltage battery to re-ignite multiple times after a fire has been extinguished.

### How to Prevent Re-ignition (Mitigating Stranded Energy Risk)

1. 12 V battery (-) terminal disconnection (To depower battery management system)
2. High-Voltage shut off (refer to page 8~9)
3. Discharging the high-voltage battery (refer to page 24)

## 7.1 Submerged or Partially Submerged Vehicles

Some emergency responses can involve a submerged vehicle. Carnival HEV that is submerged does not have high-voltage components on the vehicle's body or framework. It is safe to touch the vehicle's body or framework if there is no severe damage to the vehicle, whether it is in water or on land. In the event of the vehicle is submerged or partially submerged, take out the vehicle from the water before attempting to disable the vehicle. Drain the water from the vehicle. Use one of the methods described in page 7~9 to disable the vehicle. Then, discharge the battery by referring to page 24.

### **WARNING**

- If severe damage causes high-voltage components to become exposed, responders should take appropriate precautions and wear appropriate insulated personal protective equipment.
- Do not attempt to disengage a service interlock connector while the vehicle is in water.

Failure to follow these instructions can lead to death or serious injuries by electrocution.

### 8.1 Towing and Transportation

In the event of an accident, the high-voltage system must be disabled. The service interlock connector must be removed from the high-voltage battery according to one of the methods described in page 7-11 to disable the vehicle. Towing the Carnival HEV vehicle is not different from towing a conventional AWD vehicle. If emergency towing is necessary, we recommend having it done by an authorized Kia dealer or a commercial tow-truck service. Proper lifting and towing procedures are necessary to prevent damage to the vehicle. The use of wheel dollies or flatbed is recommended.

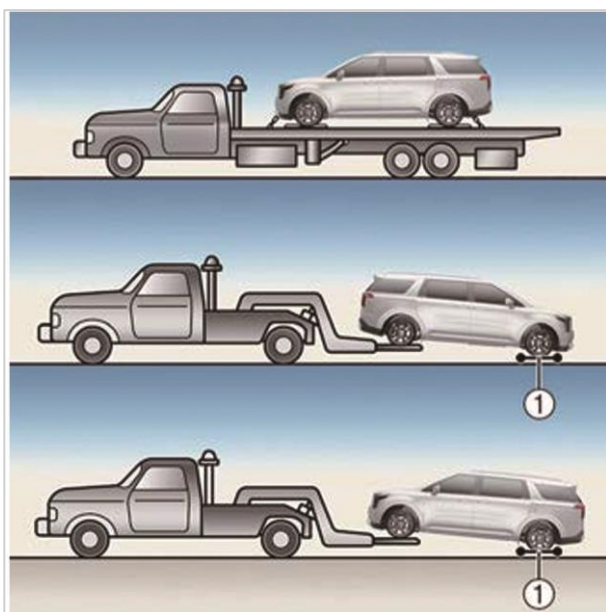

#### **WARNING**

- Do not tow the vehicle with the driven wheels of 2WD and front/rear wheels of AWD on the ground as this may cause damage to the vehicle (the vehicle motor may generate electricity and the motor components may be damaged or a fire may occur.)

- Do not tow with sling-type equipment. Use wheel lift or flatbed equipment.



### 8.2 Storage of damaged vehicle with the damaged battery

- Drain fluids and water, then disconnect the negative (-) terminal of the 12 V battery before storing a damaged vehicle.
- Also, remove the water inside the battery or vehicle, then disengage (pull up) the service interlock connector from the high-voltage battery before storing a damaged vehicle.
- Place the vehicle in an open space away from any structure, vehicle, or building.
- Then, keep an eye on the vehicle until the discharging procedures are completed.
- If the battery can be removed from the vehicle by moving the vehicle on the lift, remove and discharge the battery. (refer to the next page)

- If the battery can't be removed, set the water pool and pour water until the entire battery is submerged.  
# Water pool condition : tap water or pond water that does not contain salt
- Maintain this water level for at least 90 hours.
- Then, put salt into the water pool to make 3.5 % salt water.
- Wait for additional 48 hours in salt water.
- Drain the water and dry it.
- If it is impossible to remove or discharge the battery from the vehicle or submerge the vehicle, put a waterproof cover on the vehicle. (prevention of rainwater)

### **WARNING**

#### Battery discharging

- **DO NOT USE SALT WATER** for the first step.
- A large volume of flammable hydrogen gas can be generated in salt water due to electrolysis.
- After submerging the vehicle in pure water for at least 90 hours, put salt in the water pool.



Battery discharging in the water pool

### 8.3 Damaged Battery Storage

- To store the damaged battery safely, the battery must be discharged.
- If the battery can be removed from the vehicle, discharge the battery to prevent re-ignition.
- Discharge up to 1 volt per a cell (HEV: 72cell)
- Prepare water that does not contain salt such as tap water or pond water.
- Leave the battery in water for at least 90 hours
- Then, put salt in water to make 3.5% salt water.
- Wait for an additional 48 hours in salt water.
- Take out the battery from the container and dry it.

### **WARNING**

- Extinguish all smoke, spark, flame around the vehicle.
- Electrolyte solution is an irritant to skin.
- Do not touch or step on the spilled electrolyte.
- If electrolyte leak occurs, wear appropriate solvent resistant PPE and use soil, sand, or a dry cloth to clean up the spilled electrolyte. Be sure to adequately ventilate the area.

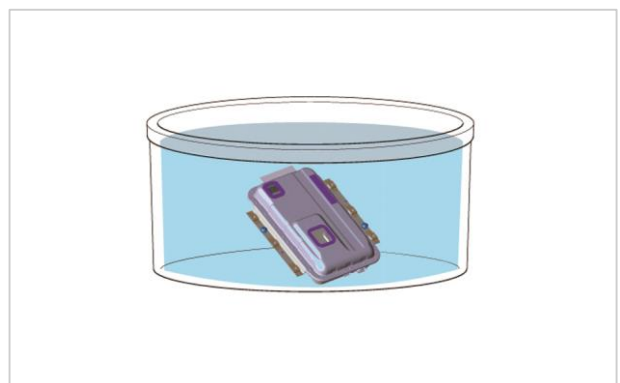

## 9.1 Emergency Starting

### Jump Starting

Do not attempt to jump start the high-voltage battery, as it cannot be jump started. In case of full discharge of the high-voltage battery, the vehicle must be towed as mentioned on page 24. In case the 12 V auxiliary battery is discharged, connect a starting device to the jump terminal in the motor room. Refer to the “Emergency Starting” section of the Owner’s Manual for additional information. Connect jumper cables in the order shown in the image and disconnect in reverse order.

### Jump Starting Procedure

1. Make sure that the booster battery is 12-Volt and that its negative terminal is grounded.
2. If the booster battery is in another vehicle, do not allow the vehicles to come in contact.
3. Turn off all unnecessary electrical loads.
4. Connect the jumper cables in the exact sequence shown in the illustration. First, connect one end of a jumper cable to the positive terminal of the fuse box (1) and then connect the other end to the positive terminal on the booster battery (2). Proceed to connect one end of the other jumper cable to the negative terminal of the booster battery (3), then the other end to a solid, stationary, metallic point away from the fuse box (4).



### **WARNING**

Do not attempt to jump start the Carnival HEV high-voltage battery.

Failure to follow these instructions will lead to serious bodily injuries or death by electrical shock.

### 9.2 Airbag system (SRS : Supplemental Restraint System)

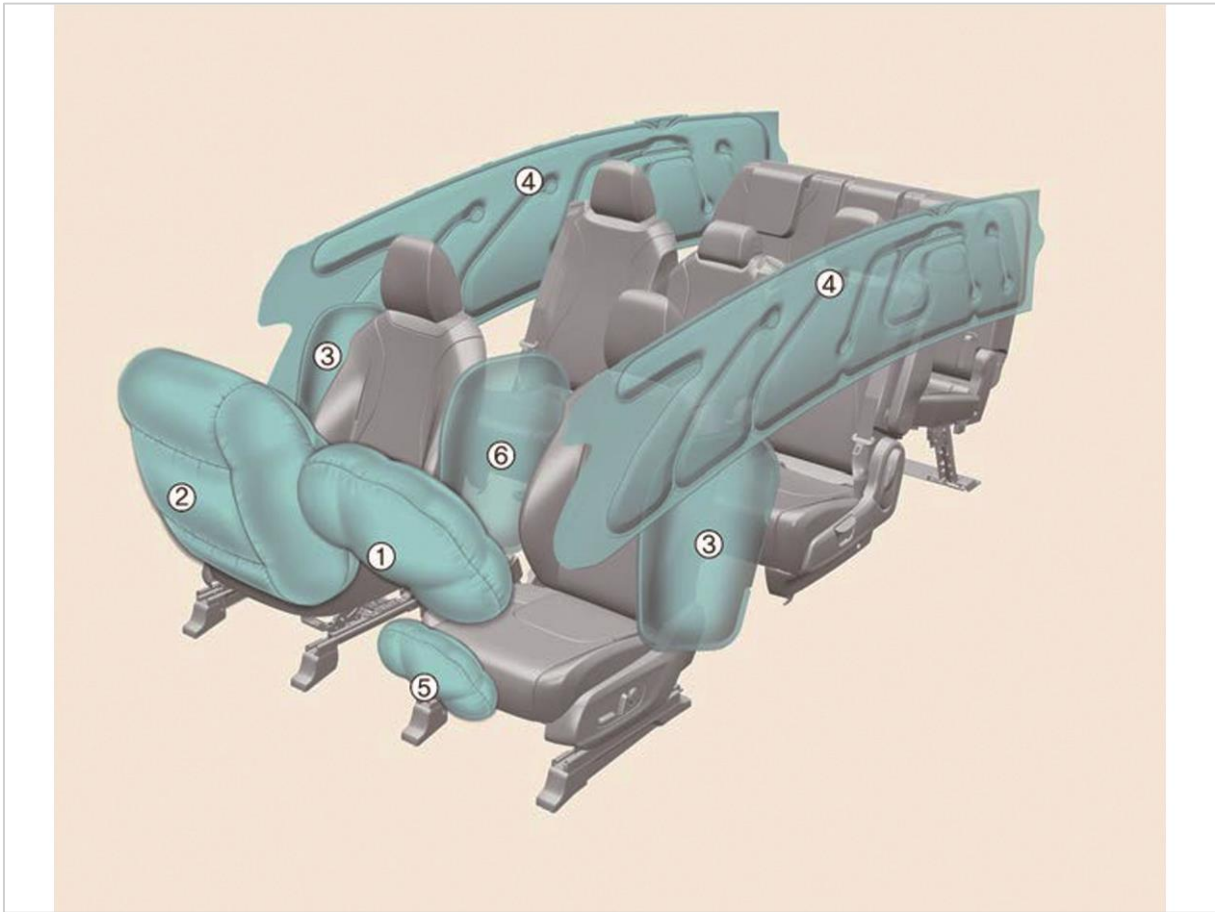

#### Airbag

Note that the actual airbags and seats in the vehicle may differ from the illustration.

Airbags of the Carnival HEV are installed in the areas shown in the image. Before performing emergency procedures, make sure the vehicle ignition switch is turned off and disconnect the auxiliary 12 V negative ( - ) battery terminal and the service interlock connector to prevent accidental deployment of undeployed airbags.

1. Driver's front air bag
2. Passenger's front air bag
3. Side air bags
4. Curtain air bags
5. Driver's knee air bag
6. Front center side air bag

### Seat Belt Pretensioner

In the Carnival HEV, not only the driver's and front passenger's seat belts but also the second-row passengers' seat belts (except the center) are equipped with pretensioners. When the seat belt pretensioners are activated in a collision, a loud noise may be heard and fine dust, which may appear to be smoke, may be visible in the passenger compartment. These are normal operating conditions and are not hazardous. The seat belt pretensioner assembly mechanisms may become hot during activation, and may need several minutes to cool down after they have been activated.



### **WARNING**

#### Undeployed airbags

To avoid injuries caused by accidental deployment of undeployed airbags.

- Do not cut the red-colored part shown in the images above and left side.
- Make sure the vehicle ignition switch is turned off, disconnect the positive connector from the engine room (located on the right side of the engine room) and wait 3 minutes or longer to allow the system to deactivate.

Failure to follow any of these instructions may result in serious injuries or death by accidental deployment of the airbag system.





Movement that inspires