

# SANTA FE

## hybrid

### **Emergency Response Guide**

# Contents

1. Identification / recognition	2
2. Immobilization / stabilization / lifting	5
3. Disable direct hazards / safety regulations	6
4. Access to the occupants	9
5. Stored energy / liquid / gases / solids	12
6. In case of fire	15
7. In case of submersion	19
8. Towing / transportation / storage	20
9. Important additional information	23

# 1. Identification / recognition

## Initial Response: Identify, Immobilize and Disable

The following procedures should be used whenever you are dealing with a SANTA FE HYBRID at an emergency scene. However, all operations should be consistent with your department's standard operating procedures, guidelines, and any applicable laws. When an HEV (hybrid electric vehicle) is damaged in a crash, the high voltage safety systems may have been compromised and present a potential high voltage electrical shock hazard. Exercise caution and wear appropriate personal protective equipment (PPE) safety gear, including high voltage safety gloves and boots. Remove all metallic jewelry, including watches and rings.

### Identify

The SANTA FE HYBRID is built on a conventional SANTA FE chassis and therefore the appearance looks very similar to the internal combustion engine model.

Emergency responders should assume that any SANTA FE you respond to is a Hybrid vehicle and respond to emergency scenarios involving the SANTA FE HYBRID accordingly, exercising extreme care and caution to avoid contact with the high voltage system within the vehicle.

# 1. Identification / recognition

## 1.1 Identifying a HYUNDAI SANTA FE HYBRID

### Front and rear view of SANTA FE HYBRID

The Brand Logo placed on the hood/tailgate and the model name "SANTA FE" is placed in the middle of the tailgate



### Engine Compartment

The SANTA FE HYBRID has a plastic cover with "Hybrid" clearly shown on it.

Additionally, there are orange colored high-voltage electrical cables in the motor compartment

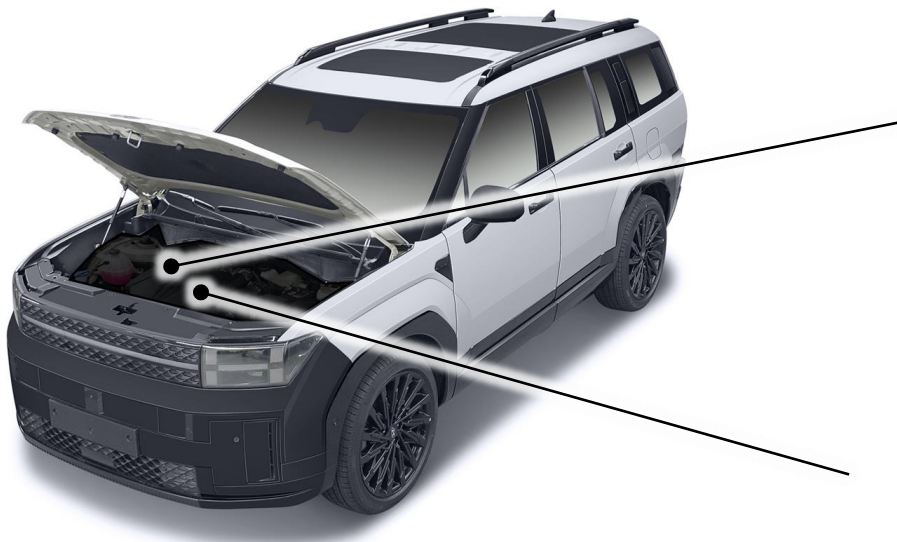

"HYBRID" on the cover



High Voltage Cables

# 1. Identification / recognition

## 1.1 Identifying a HYUNDAI SANTA FE HYBRID

### VIN Label

The VIN (Vehicle Identification Number) identifies a hybrid car with a “1” displayed in the 8th position, as shown in the below picture.

The VIN can be found:

- 1) VIN Plate can be seen through the windshield from outside.
- 2) On the vehicle certification label attached to the driver’s side center pillar.
- 3) Underneath the front passenger seat (or driver seat).

XXXXXXXX1XXXXXX

← 8th position

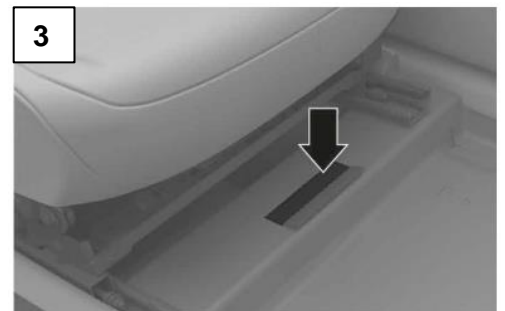
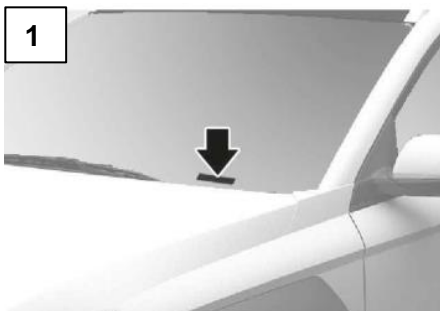

## 2. Immobilization / stabilization / lifting

### 2.1 Immobilization

The next step is to immobilize the vehicle to prevent any accidental movement that can endanger response personnel or civilians. When the SANTA FE HYBRID is damaged in a crash, the vehicle may appear to be shut off when it is not due to no engine sounds.

When the "READY" mode light is illuminated on the Instrument Panel, the vehicle can move silently using the electric motor. Responders should approach the vehicle from the sides and stay away from the front or rear as they are potential paths for vehicle movement. Be sure to immobilize the vehicle in the following manner.

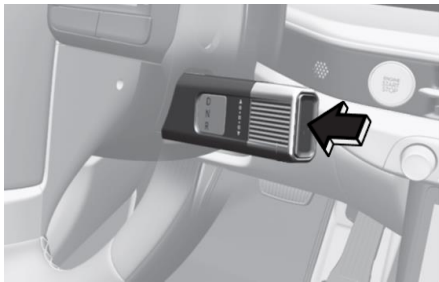

Put the vehicle in P (Park) position by pressing the 'P' button on the rotary shifter

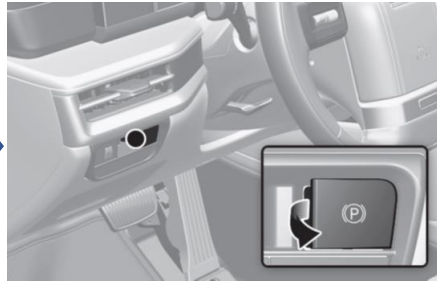

Engage Parking Brake



Chock the Wheels

### 2.2 Vehicle Stabilization

Use standard stabilization (lift) points, as shown beside. Always be sure to connect to a structural member of the vehicle and avoid placing cribbing under high voltage cables, and other areas not normally considered acceptable.

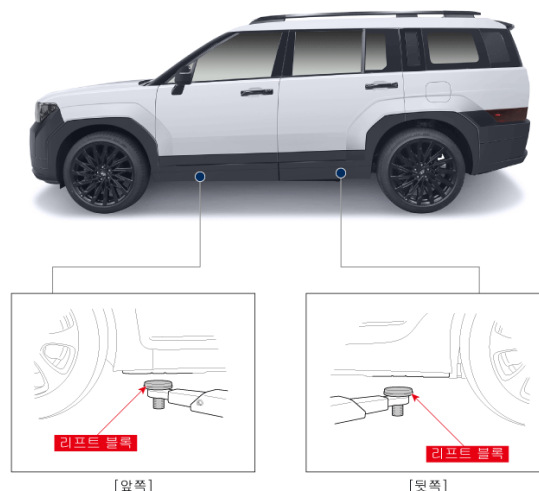

### 3. Disable direct hazards / safety regulations

The final step in the initial response process, conducted after immobilizing the vehicle, is to disable the vehicle, its SRS components and the high voltage electrical system. To prevent current flow through the system, use the following procedure to disable the vehicle.



#### 3.1 Disabling the System

1. Confirm the status of the READY light on the instrument panel. If the **READY** light is illuminated, the vehicle is ON.
  - a) If the READY light is NOT illuminated, the vehicle is off. Do not push the “POWER” START/STOP button because the vehicle may start (go into READY mode).
  - b) To turn OFF the system, Position the shift lever in Park and press the POWER button.

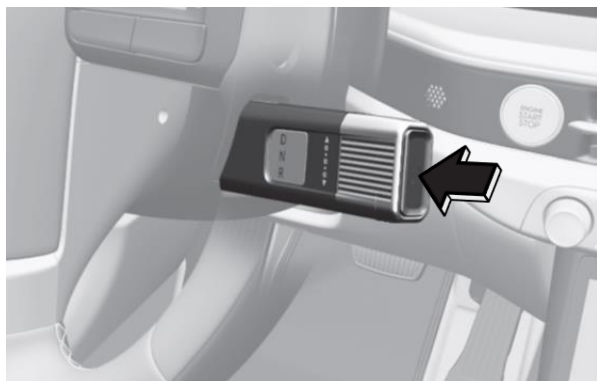

Put the vehicle in P



“POWER” START/STOP Button

## 3. Disable direct hazards / safety regulations

### Without depressing the brake pedal

Pressing POWER button	Button Position/LED	Vehicle condition
One time	ACC/ON	Electrical accessories are operational.
Two times	ON/ON	The warning lights can be checked before the vehicle is started.
Three times	OFF	Off

### While depressing the brake pedal

Pressing POWER button	Button Position/LED	Vehicle condition
One time	START/OFF	Ready to drive

2. If necessary, lower the windows, unlock the doors and open the tail gate as required, before disconnecting the 12V battery. Once the 12V battery is disconnected, power controls will not operate.
3. Before disconnecting the 12V battery, remove the Smart Key at least 6 feet away from the vehicle to prevent accidental restart.

### 3.2 Disconnect the 12V auxiliary battery

Disconnect the 12V battery located at the luggage compartment.

- a. Open the tailgate and locate the 12V battery
- b. Disconnect the negative terminal(A)

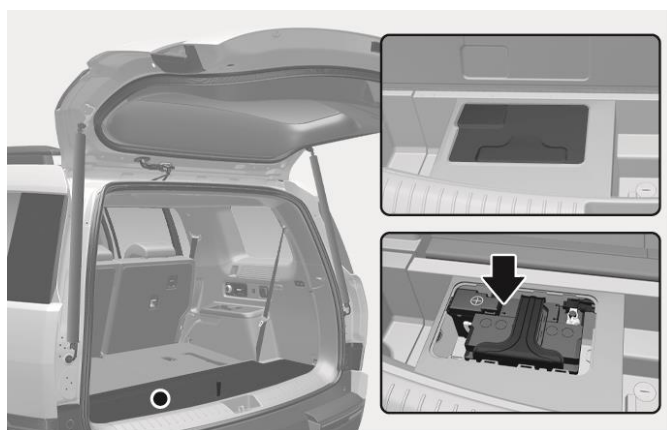



## 3. Disable direct hazards / safety regulations

### 3.3 Disconnect the High voltage battery

In case of emergency, disconnect the High-voltage Cut-off Switch (A) to isolate the high voltage of the battery.

- a. Remove the fuse box cover located at the engine compartment.

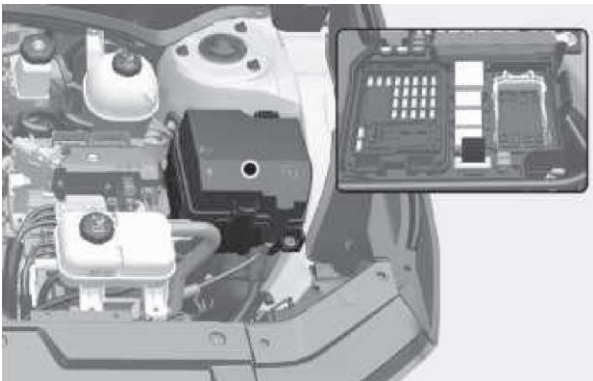

- b. Disconnect the High voltage cut-off Switch (A)

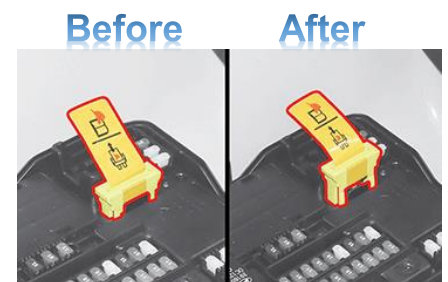

#### **⚠ WARNING** Electrocutation Risk!

- Before engaging in emergency response procedures, ensure the vehicle is disabled and wait for more than 5 minutes to allow the capacitor in the high voltage system to discharge to avoid electrocution.
- Exposed cables or wires may be visible inside or outside the vehicle. To prevent injury or death due to electrical shock, never touch the wires or cables before disabling the system, to prevent injury or death due to electrical shock.

Failure to follow any of these instructions may result in serious injury or death by electrocution.

#### **⚠ WARNING** Explosive Risk!

- SRS components may remain powered and active for up to 3 minutes after the 12V electrical system is shut off or disabled. Disconnect the battery cable and wait for at least 3 minutes before beginning work.

Failure to follow any of these instructions may result in serious injury or death from accidental deployment of the airbag system.

## 4. Access to the occupants

### 4.1 Extraction Operations

The SANTA FE HYBRID is a Hybrid model. Because of the high voltage components contained therein, first responders should pay special attention when they extract occupants in the car. Before performing any extraction operations, the first responders should "Identify, Immobilize and Disable" the vehicle as discussed in sections on emergency procedures.

### 4.2 Vehicle Stabilization

Use standard stabilization (lift) points, as shown beside. Always be sure to connect to a structural member of the vehicle and avoid placing cribbing under high voltage cables, and other areas not normally considered acceptable.

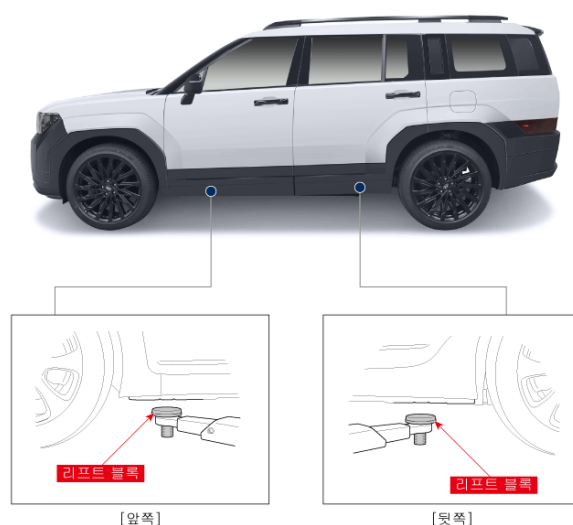

### 4.3 Extraction tools and procedure

When responding to an incident involving a SANTA FE HYBRID, we recommend that the first responders follow their organization's standard operating procedures for dealing with vehicle emergencies.

When the first responders cut the vehicle, they should always pay special attention to the airbag system, orange colored high voltage cables and other high voltage components so that the parts are not damaged and to prevent a risk of explosion.

## 4. Access to the occupants

### 4.4 Location of High strength steel

In these images, the areas marked in red indicate sections where the hot stamping technique has been applied. Depending on the tools used, cutting the areas with hot stamping can be challenging or even impossible.

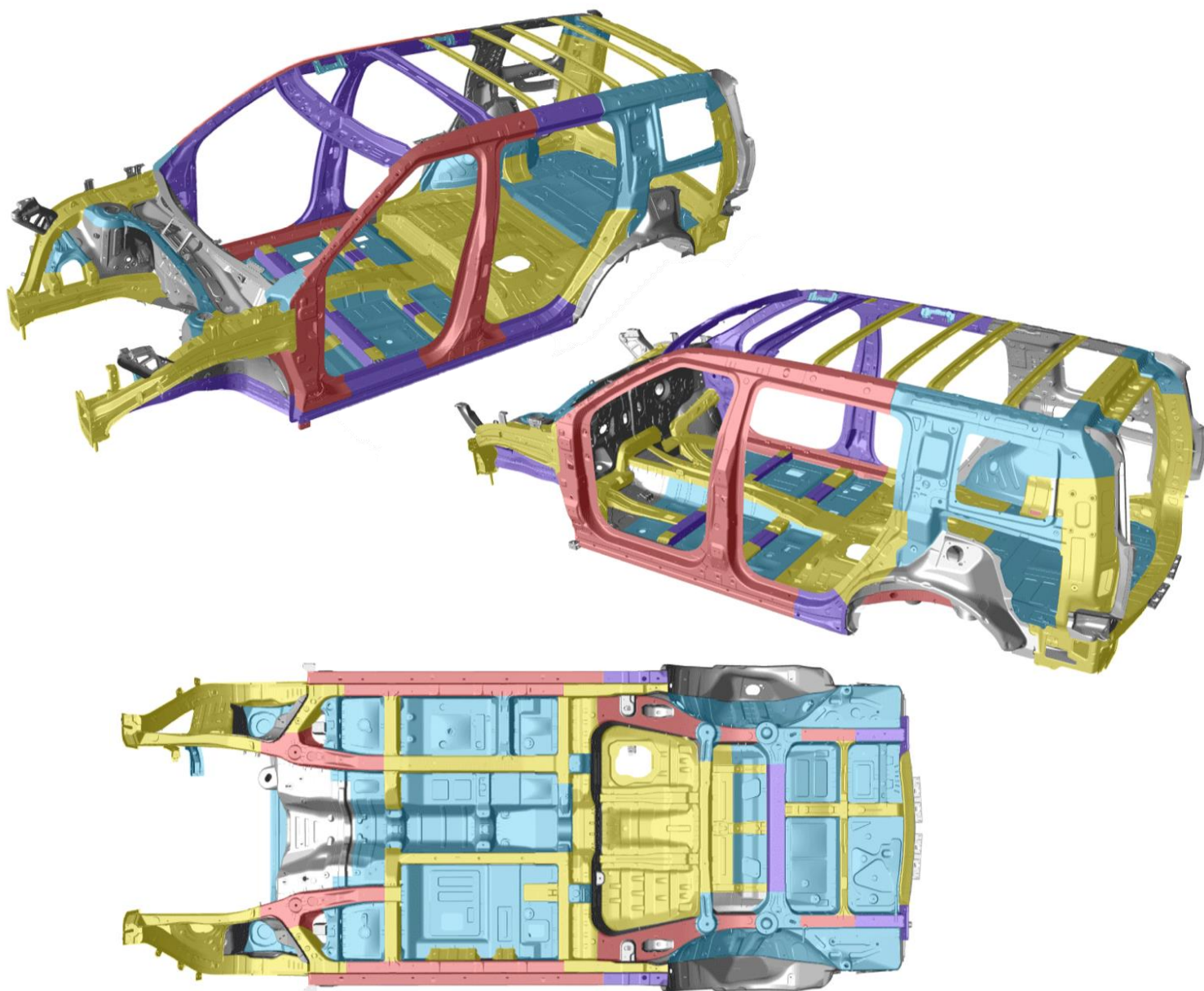









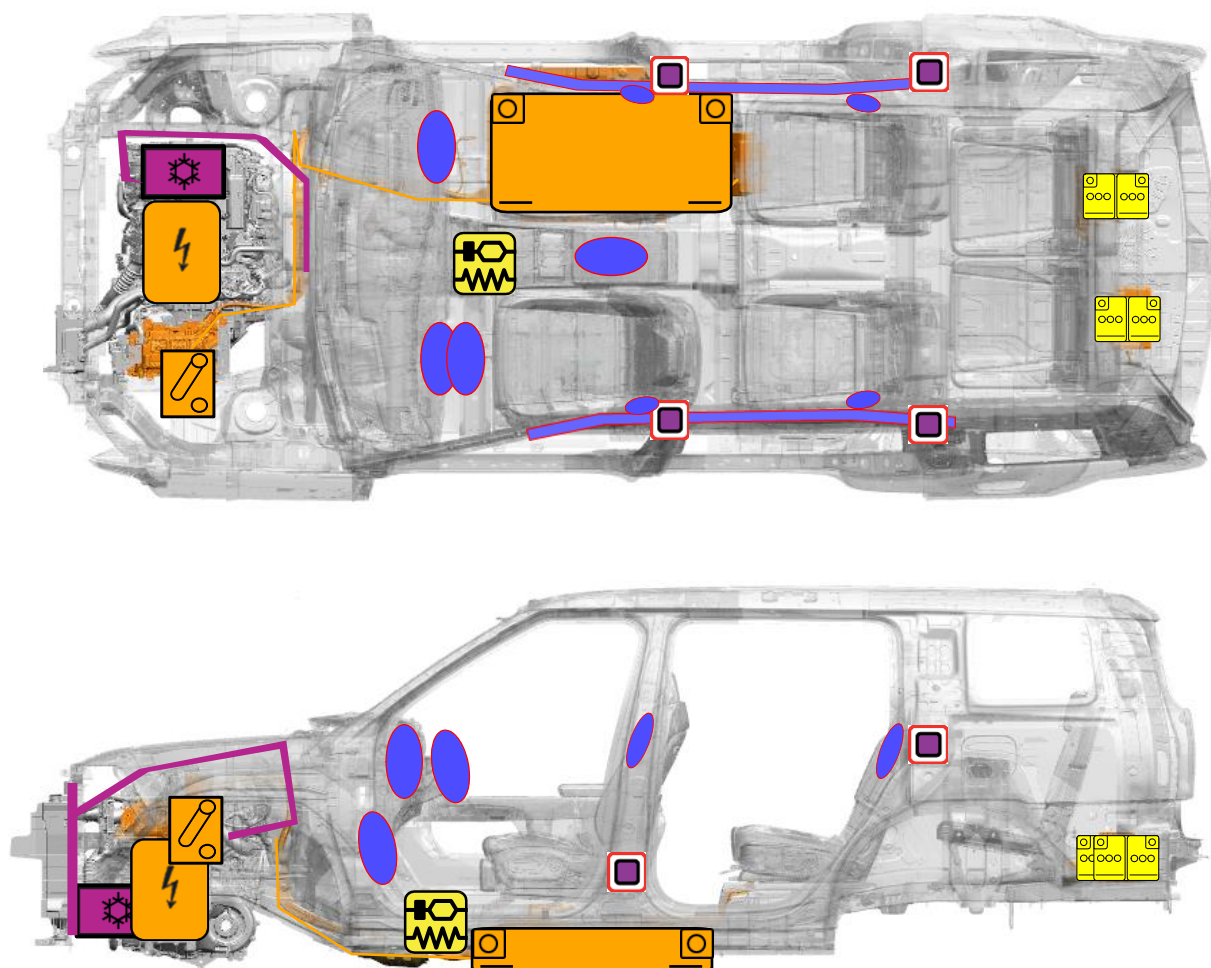



- Mild Steel
- High Strength Steel
- Advanced High Strength Steel
- Ultra High Strength Steel
- Hot Stamping

## 4. Access to the occupants

### 4.5 Occupants rescue guide

When dealing with an emergency situation, check the components as below.



 Supplemental Restraint System Control Module (SRSCM)	 Airbag	 Airbag Gas Inflators
 High voltage cable	 12V Battery	 Air-conditioning line
 High voltage disconnect	 OBC (On – Board Charger)	 Motor Drive Unit
 High Voltage Battery	 Air-conditioning component	 Seat belt pretensioner



## 5. Stored energy / liquid / gases / solids

### 5.1 High voltage system

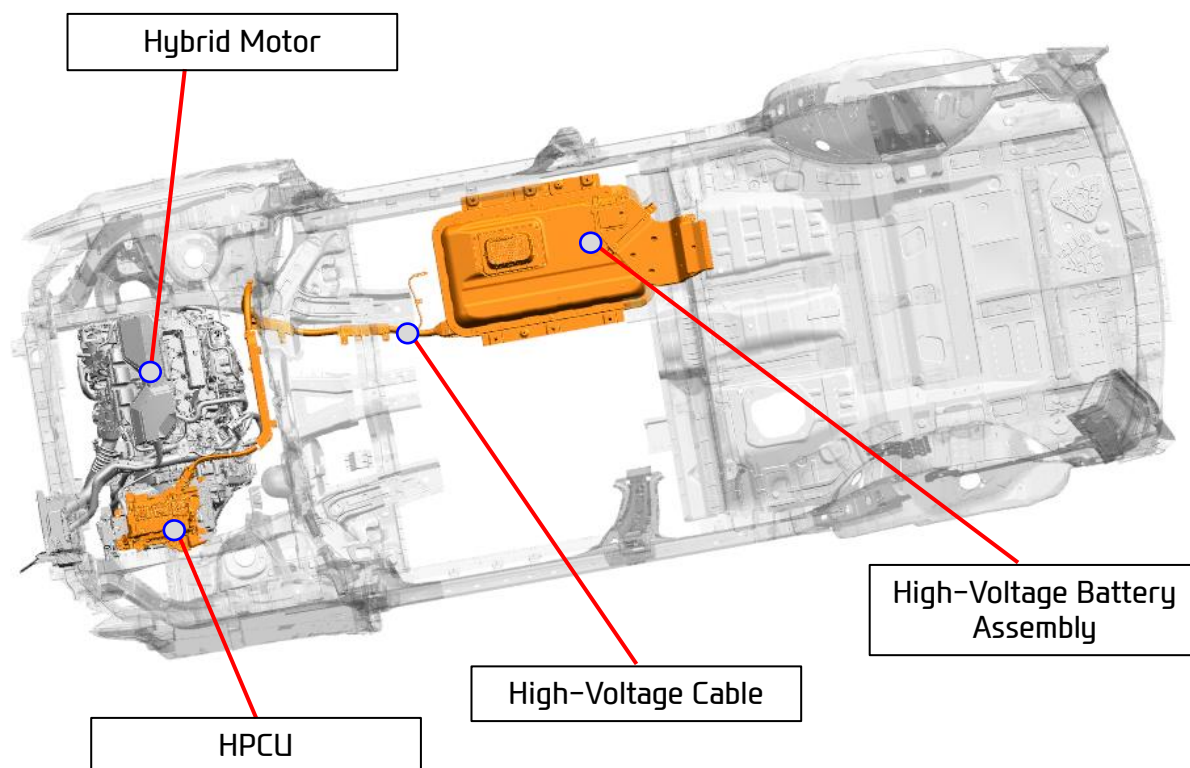

HPCU	Hybrid Power Control Unit
Motor	When current flows through the coil. It generates a rotating magnetic field and generates motor torque.
High Voltage Battery	Supplies electric energy to traction motor and stores generated electric energy .
High Voltage Cable	The high-voltage cabling is orange per the SAE standard.

#### **⚠ CAUTION**

- *There is the capacitor inside the HPCU. Wait 5+ minutes for the capacitor to discharge after disabling the vehicle.*

# 5. Stored energy / liquid / gases / solids

## 5.1 High voltage system

### High voltage (HV) battery

The HV Lithium ion polymer battery supplies and stores electric energy, to the traction motor, and is located under the SANTA FE HYBRID chassis.

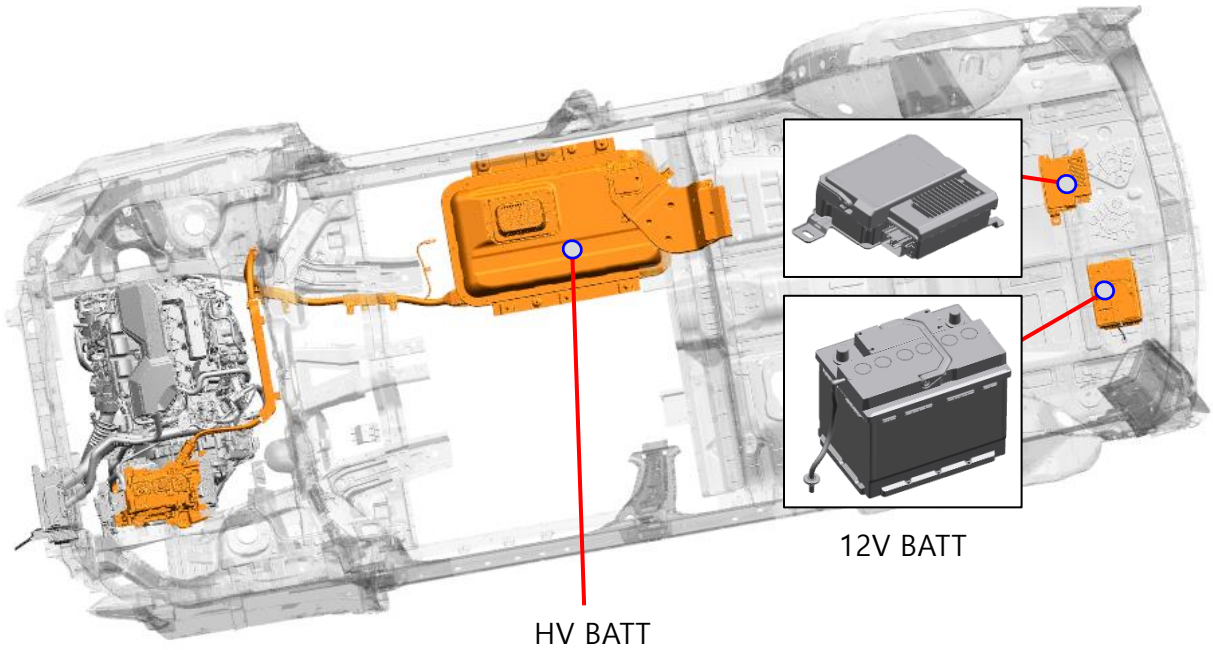

### ※ Specification

<b>Motor</b>	Type	Permanent magnet synchronous motor
	Max. Output (kW)	47.7
	Max Torque (Nm)	264
<b>High Voltage Battery</b>	Rated Voltage (V)	270
	Energy (Wh)	1485
	Quantity for Pack (Cell / Module)	72 cells / 9 modules

## 5. Stored energy / liquid / gases / solids

### 5.2 High voltage orange cabling

The High Voltage cabling is orange, per Society of Automotive Engineers (SAE) standards. Cables run under the floor of the vehicle and connect the High Voltage Battery to the HPCU, Motor, LDC (Low Voltage DC Converter), Inverter, A/C compressor and other High Voltage components located towards the front of the vehicle.

The presence of orange cables under the hood, in the under-floor battery compartment, or HV cables under the car, identifies the vehicle as an electric vehicle.

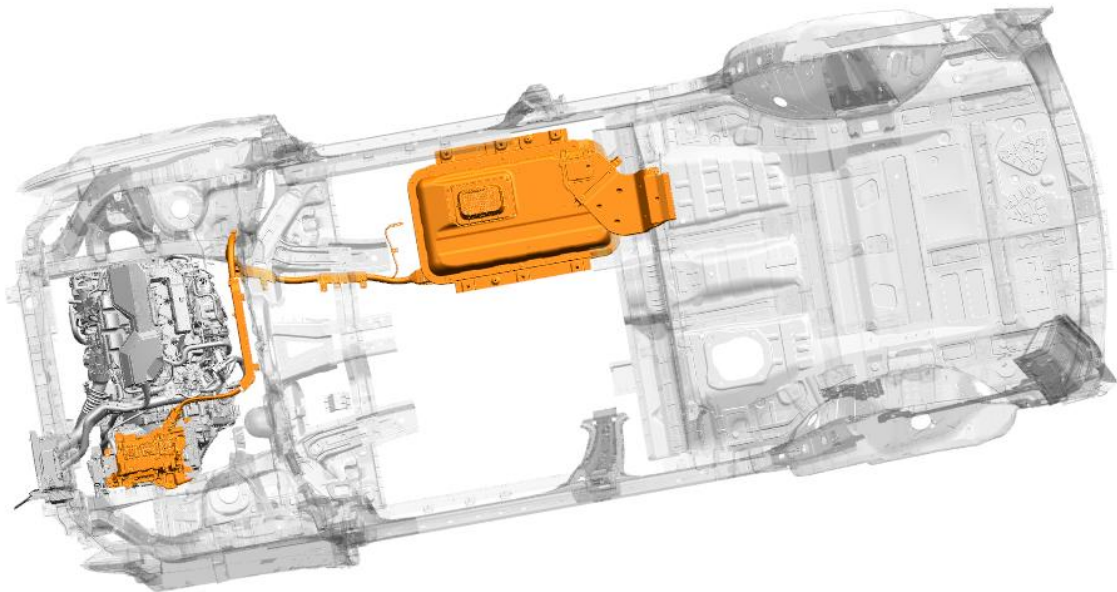

#### CAUTION

- *Never cut or disconnect the high voltage orange cabling and connectors without first disabling the HV system (refer to page 6).*
- *Exposed cables or wires may be visible inside or outside the vehicle. Never touch the metal chassis wires, cables, connectors, or any electric components before disabling the system, and; or shorted to the vehicle chassis.*

*Failure to follow these instructions will lead to serious bodily injury or death by electrical shock.*

## 6. In case of fire

### 6.1 Firefighting Operations

Strict precautions must be taken while conducting firefighting operations due to following

Reasons:

- Lithium-ion batteries contain electrolyte that can vent, ignite, and produce sparks when subjected to temperatures above 300°F.
- Vehicle may burn rapidly with a flare-burning effect.
- Even after the high-voltage battery fire appears to have been extinguished, renewed or delayed fire can occur.
  - Use a thermal imaging camera to ensure the high voltage battery is completely cooled before leaving the incident.
  - Always advise second responders that there is a risk of the battery re-igniting.
  - In a fire, submersion or a collision that has compromised the high voltage battery, always store it in an open area with no exposures within 50 feet.
- A burning battery could release hydrogen fluoride, carbon monoxide, and carbon dioxide gasses. Use NIOSH/MSHA approved full-face self-contained breathing apparatus (SCBA) with full protective gear. Even if the high-voltage battery pack is not directly involved in a vehicle fire, approach the vehicle very carefully.

### 6.2 Extinguishers

- Small fires that do not involve the high voltage battery should be extinguished using an ABC fire extinguisher. (ex. Fire caused by wiring harnesses, electrical components, etc.)
- Do not attempt to extinguish fires that involve the high voltage battery with small amounts of water as this can result in electrocution. Fires that involve the high voltage battery should be extinguished using large amounts of water (min 2,650 gallons) to cool the high voltage battery. Fire fighters should not hesitate to pour larger amounts of water on the vehicle in such scenarios. Make sure the battery is fully cooled to avoid fire re-ignition.



## 6. In case of fire

### 6.3 How to deal with the situation

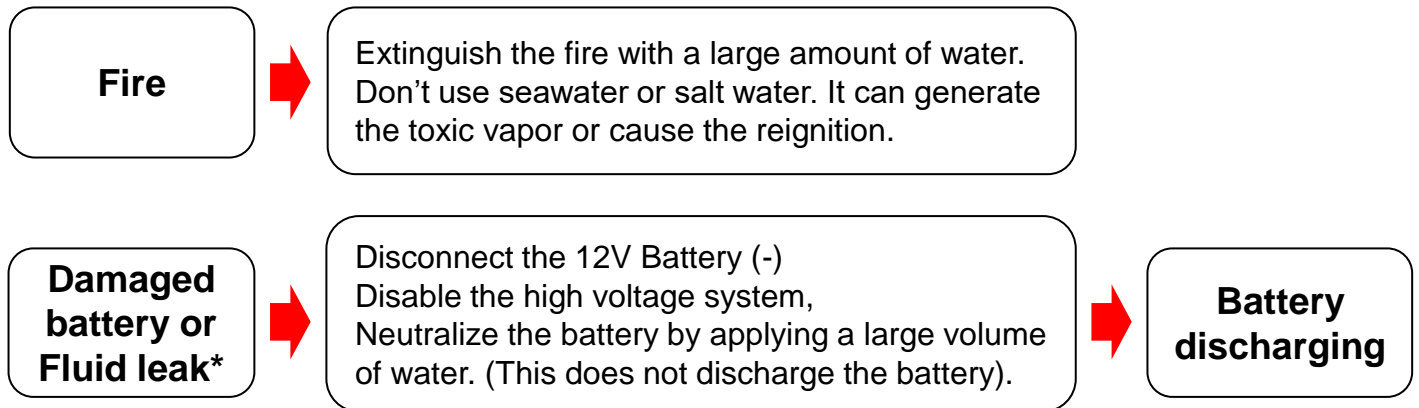

\*If electrolyte solution leakage, or any damage to the H.V battery casing is observed

#### 6.3.1 Vehicle fire

- Use a large volume of water (min 2,650 gallons). The water must cool down the battery.
- If water is put into the high voltage battery casing, it will be better to cool down the battery. (But never attempt to penetrate the HV battery or its casing to apply water.)



- Soaking the vehicle in the container filled with water can be an effective way to extinguish the fire.

## 6. In case of fire

### 6.3.2 High Voltage Battery Damage and Fluid Leaks

If electrolyte solution leakage, or any damage to the Lithium ion battery casing is observed, the first responders should attempt to neutralize the battery by applying a large volume of water to the battery pack while wearing appropriate Personal Protective Equipment (PPE). The neutralization process helps stabilize the thermal condition of the battery pack but does not discharge the battery.

- Do not put any smoke, spark, flame around the vehicle.
- Do not touch or step on the spilled electrolyte.
- If electrolyte leak occurs, wear appropriate solvent resistant PPE and use soil, sand, or a dry cloth to clean up the spilled electrolyte. Be sure to adequately ventilate the area.

#### **CAUTION** Electrolyte Irritation

*The high voltage battery contains electrolyte solution. To avoid exposure to electrolyte solution and serious personal injury, always wear appropriate solvent resistant PPE (Personal Protective Equipment) and SCBA (Self-Contained Breathing Apparatus).*

- *Electrolyte solution is an eye irritant – In the event of contact with eyes, rinse with plenty of water for 15 minutes.*
- *Electrolyte solution is a skin irritant. Therefore, in the event of contact with skin, wash off with a soap.*
- *Electrolyte liquid or fumes coming into contact with water will create vapors in the air from oxidization. These vapors may irritate skin and eyes. In the event of contact with vapors, rinse with plenty of water and consult a doctor immediately.*
- *Electrolyte fumes (when inhaled) can cause respiratory irritation and acute intoxication. Inhale fresh air and wash mouth with water. Consult a doctor immediately.*

## 6. In case of fire

### 6.4 High Voltage Battery re-ignition by stranded energy

Damaged cells in the high voltage battery can experience thermal runaway\* and reignition. To prevent reignition, the first responder and second responder need to be aware of the risk of stranded energy\*\* which remains in the damaged cells and lead to reignition.

\*Thermal runaway : The originating cause of thermal runaway is generally short-circuiting inside a battery cell and a resulting increase in the cell's internal temperature.

Battery produces heat with thermal runaway and it can spread from one battery cell to many cells, in a domino effect.

\*\*Stranded energy : Energy remains inside any undamaged battery cells after the accident. That stranded energy can cause a high voltage battery to reignite multiple times after firefighters a fire.

### How to prevent reignition (Mitigating stranded energy risk)

Use a thermal imaging camera to ensure the high voltage battery is completely cooled before leaving the incident.

Always advise second responders that there is a risk of the battery re-igniting.

1. Disconnect the 12V battery (-) terminal -to depower the battery management system
2. Disable the high voltage system - refer to page 6-8
3. Discharge the high voltage battery - refer to page 21-22

## 7. In case of submersion

### 7.1 Submerged or Partially Submerged Vehicles

Some emergency responses can involve a submerged vehicle. A SANTA FE HYBRID that is submerged does not have high-voltage components on the vehicle's body or framework. It is safe to touch the vehicle's body or framework if there is no severe damage to the vehicle, whether it is in water or on land.

In the event of the vehicle is submerged or partially submerged, remove the vehicle from the water before attempting to disable the vehicle. Drain the water from the vehicle. Use one of the methods described in page 6-8 to disable the vehicle.

Then, discharge the battery by referring to page 21-22.

#### CAUTION

- If severe damage causes high voltage components to become exposed, responders should take appropriate precautions and wear appropriate insulated personal protective equipment.

Failure to follow these instructions can lead to death or serious injury by electrocution.

## 8. Towing / Transportation / storage

### 8.1 Towing and Transportation

In the event of an accident, the high voltage system must be disabled. The safety plug must be removed from the high voltage battery according to one of the methods described in page 6-8 to disable the vehicle.

Towing the SANTA FE HYBRID Vehicle is not different from towing a conventional electric vehicle. If emergency towing is necessary, we recommend having it done by an authorized Hyundai dealer or a commercial tow-truck service. Proper lifting and towing procedures are necessary to prevent damage to the vehicle. The use of wheel dollies or flatbed is recommended.

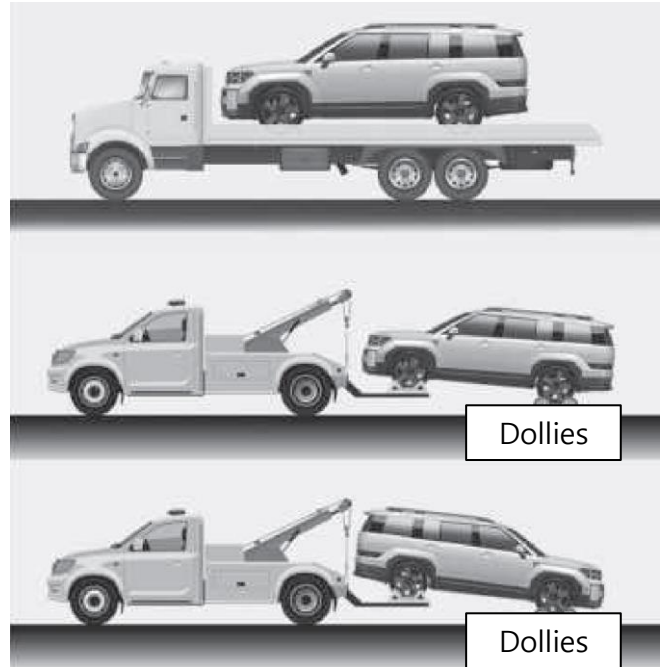

#### CAUTION

- *Do not tow with sling-type equipment. Use wheel lift or flatbed equipment.*
- *Never tow the vehicle with the front wheels on the ground (forward or backward), as this may cause fire or damage to the motor.*

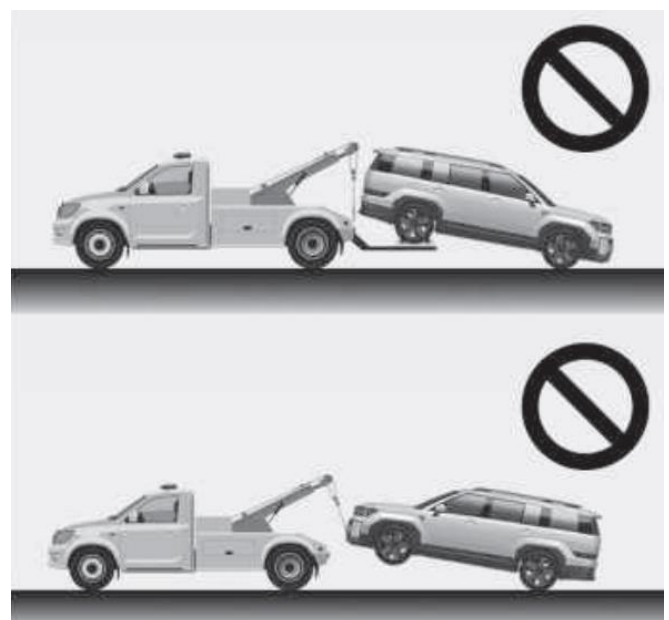

## 8. Towing / Transportation / storage

### 8.2 Storage of damaged vehicle with the damaged battery

- Drain fluids and water, then disconnect the 12 V battery connector and interlock connector before storing a damaged vehicle.
  - Place the vehicle in an open space away from any structure, vehicle, or building.
  - Then, monitor the vehicle until the discharging procedures are completed.
  - If the battery can be removed from the vehicle by moving the vehicle on the lift, remove and discharge the battery.
  - If the battery can't be removed, place the vehicle into a sufficiently large container and add enough water until the entire battery is submerged.
  - Add enough salt to the water container to create a 2% saltwater solution.
  - Leave the battery submerged in the saltwater solution for 3 days.
  - Then, drain the water and dry the battery.
  - If the high voltage battery cannot be removed or the vehicle cannot be flooded, store the vehicle with a waterproof cover.
- ※ Waterproof cover : size/material that can prevent water from entering the battery



**Battery discharging**

## 8. Towing / Transportation / storage

### 8.3 Battery Storage

- To store the damaged battery safely, the battery must be discharged.
- If the battery can be removed from the vehicle, discharge the battery to prevent re-ignition.
- Place the battery into a sufficiently large container and add water until the battery is completely submerged.
- Add enough salt to the water container to create a 2% saltwater solution.
- Leave the battery submerged in the saltwater solution for 3 days.
- Remove the battery from the saltwater solution and dry it.

#### CAUTION

- *Extinguish all smoke, spark, flame around the vehicle.*
- *Electrolyte solution is a skin irritant.*
- *Do not touch or step on the spilled electrolyte.*
- *If electrolyte leak occurs, wear appropriate solvent resistant PPE and use soil, sand, or a dry cloth to clean up the spilled electrolyte. Be sure to adequately ventilate the area.*

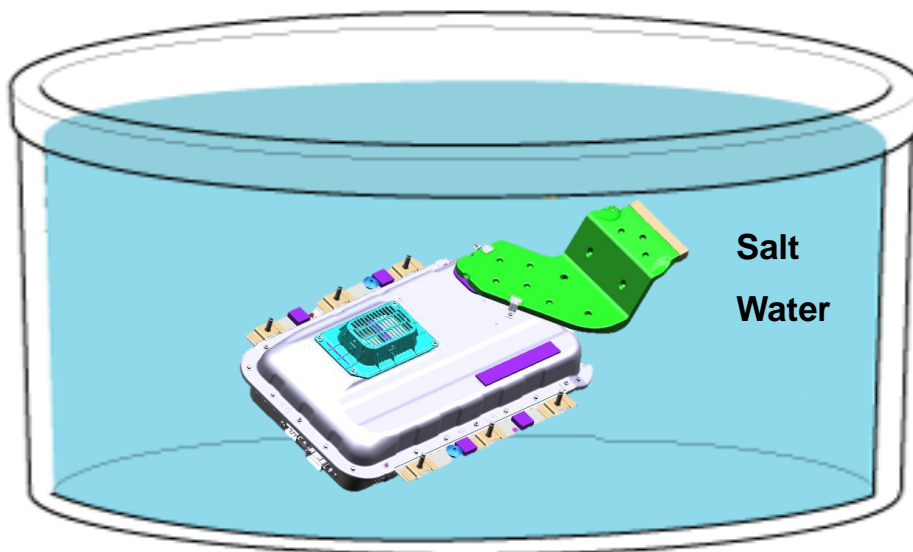

## 9. Important additional information

### 9.1 Emergency Starting

#### Jump Starting

1. Make sure the booster battery is 12V and that its negative terminal is grounded.
2. If the booster battery is in another vehicle, do not allow the vehicles to come in contact.
3. Turn off all unnecessary electrical loads.

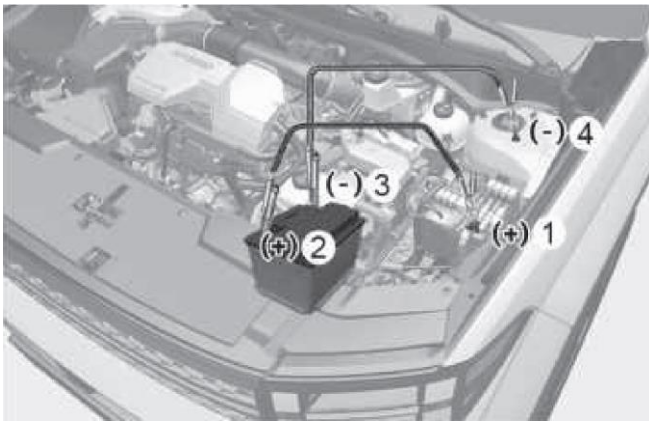

4. Open the hood and then remove the fuse cover (A).
5. Follow the procedure below to connect the jumper cables: Connect the jumper cable to the discharged battery (+) terminal **(1)**, then connect the other end to the positive terminal of the booster battery or assisting vehicle **(2)**. Connect one end of the other jumper cable to the booster battery (-) terminal **(3)**, then the other end to a solid, stationary, metallic point away from the fuse box **(4)**.
6. Start the engine of the assisting vehicle and let it run for a few minutes.
7. Press the 12V BATT RESET button and then Start your vehicle as soon as possible.

If the cause of your battery discharging is not apparent, we recommend that the system be checked.

#### CAUTION

- Do not attempt to jump start the high voltage battery.
- Do not jump start another vehicle with hybrid vehicle. Jump starting another vehicle will damage the hybrid vehicle's 12V battery (Lithium Polymer type).



## 9. Important additional information

### 9.2 Airbag system (SRS: Supplemental Restraint System)

#### Airbag

Ten airbags are installed in the SANTA FE HYBRID, located in the areas shown in the image below. Before performing any emergency procedure, make sure the vehicle ignition switch is turned off and disconnect the 12V auxiliary battery to prevent accidental deployment of undeployed airbags.

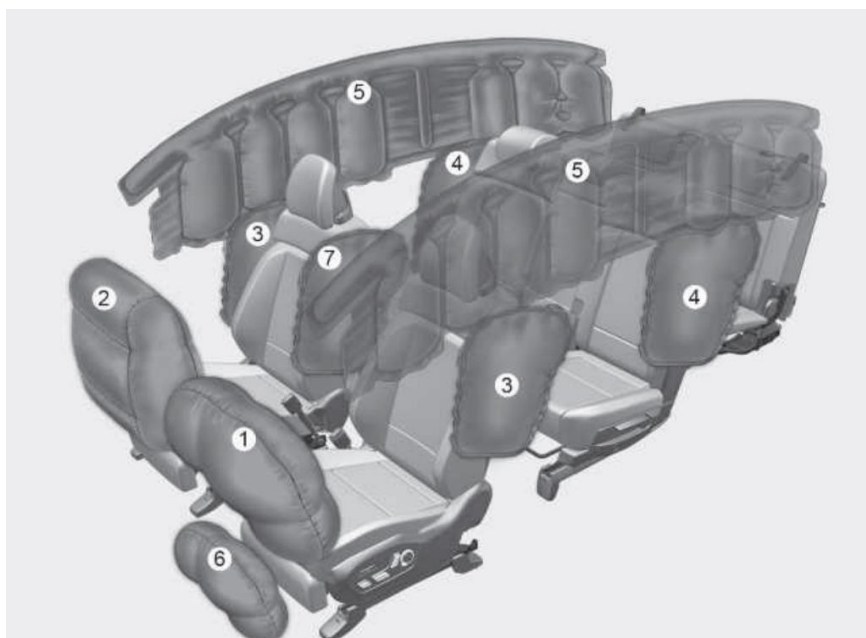

- (1) Driver front airbag
- (2) Passenger front airbag
- (3) Front Side airbag (x2)
- (4) Rear Side airbag (x2)
- (5) Curtain airbag (x2)
- (6) Driver's knee air bag
- (7) Front center side air bag

\* The actual air bags and seats in the vehicle may differ from the illustration.

#### Seat Belt Pretensioner

In the SANTA FE HYBRID, the driver's and front passenger's seat belts are equipped with pretensioners. When the seat belt pretensioners are activated in a collision, a loud noise may be heard and fine dust, which may appear to be smoke, may be visible in the passenger compartment. These are normal operating conditions and are not hazardous. The seat belt pretensioner assembly mechanisms may become hot during activation and may need several minutes to cool down after they have been activated.

## 9. Important additional information

### Airbag system components

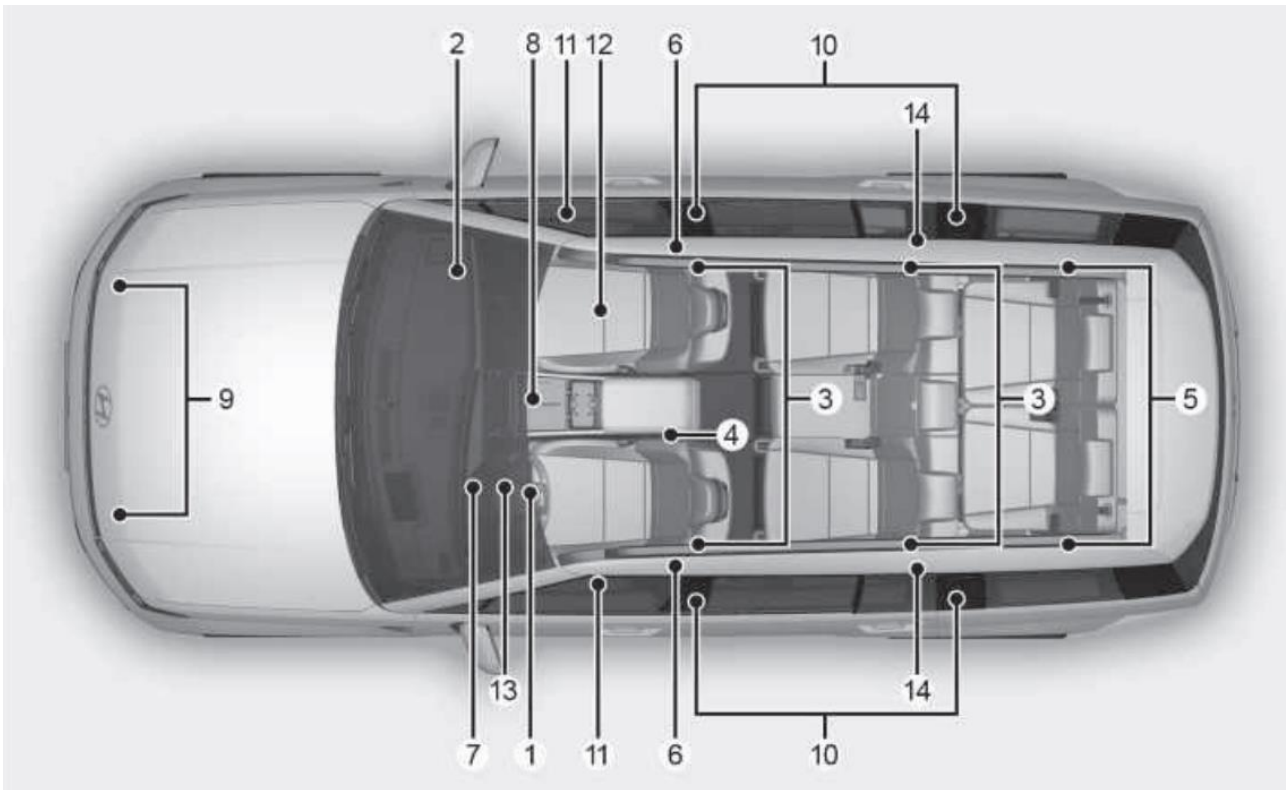

- |                                     |   |
|-------------------------------------|---|
| 1. Driver's air bag module          | 8. SRS control module (SRSCM) / Rollover sensor |
| 2. Passenger's air bag module       | 9. Front impact sensors                         |
| 3. Side air bag modules             | 10. Side impact sensors (acceleration)          |
| 4. Front center side air bag module | 11. Side impact sensors (pressure)              |
| 5. Curtain air bag modules          | 12. Occupant Classification System (OCS)        |
| 6. Front retractor pre-tensioner    | 13. Driver's knee air bag module                |
| 7. Air bag warning light            | 14. Rear retractor pre-tensioner                |

### **CAUTION** Undeployed Airbags

*To avoid injuries caused by accidental deployment of undeployed airbags*

- *Do not cut the airbag system shown in the image above.*
- *Make sure the vehicle ignition switch is turned off, disconnect the 12V auxiliary battery and wait 3 minutes or longer to allow the system to deactivate.*

*Failure to follow any of these instructions may result in serious injury or death from accidental deployment of the airbag system.*

## 9. Important additional information

### Seat belt System

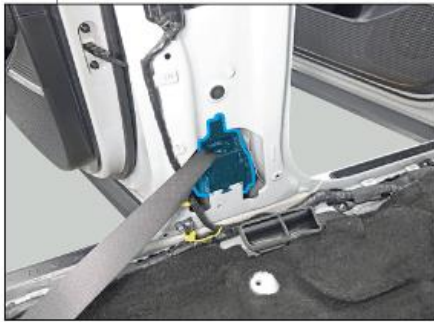

[1]

1) Front Seatbelt Pretensioner



[2]

2) Rear Seatbelt Pretensioner

